

PRODUCT IMAGE

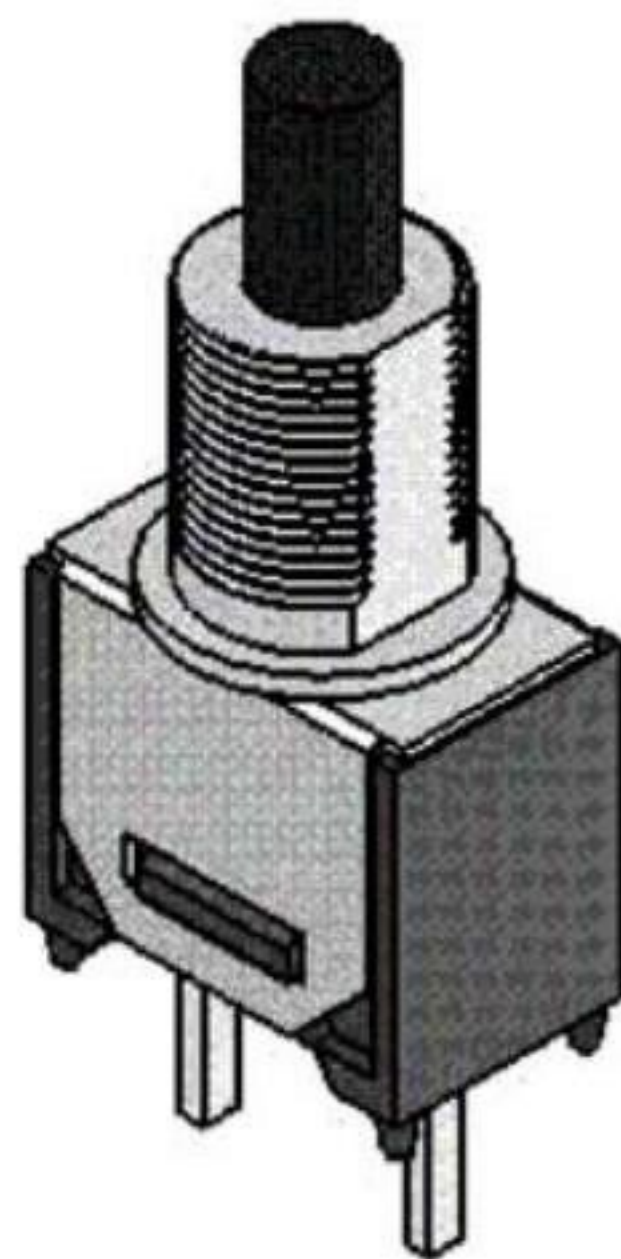

P.C.MOUNTING

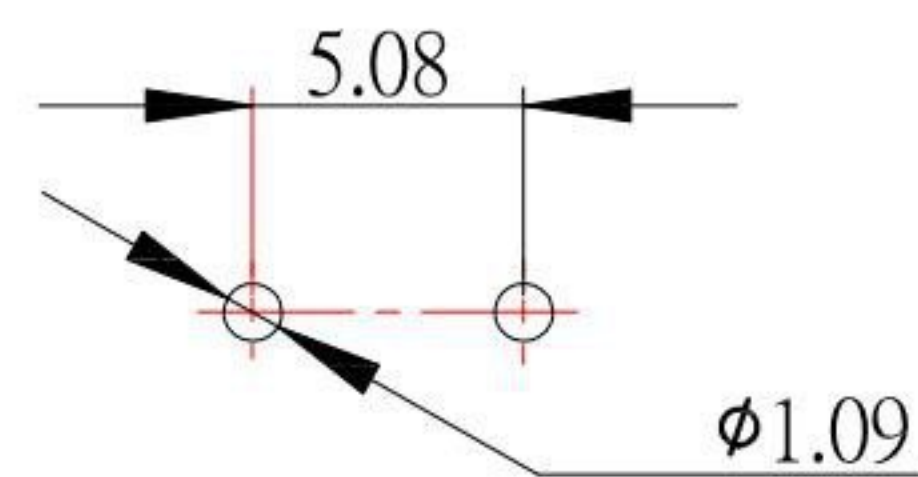

SCHEMATIC

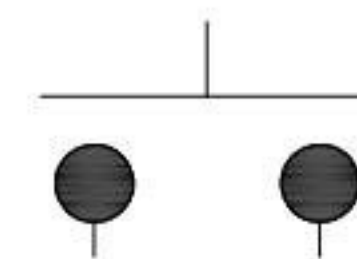

SPECIFICATIONS:

- CONTACT RATING : 1 AMPS @ 120 V AC or 28 V DC.  
0.4 VA AMPS @ 20V AV or DC.
- ELECTRICAL LIFE : 30,000 make-and-break cycles at full load.
- CONTACT RESISTANCE : 20 mΩ max. initial @ 2-4 VDC  
100 mA , for both silver and gold plated contacts.
- INSULATION RESISTANCE : 1,000 MΩ min
- DIELECTRIC STRENGTH : 1,000 V RMS @ sea level.
- OPERATING TEMPERATURE : -30°C to 130°C

MATERIALS:

- CASE : Dially phthalate (DAP)(UL-94V-0)
- PLUNGER : Thermoplastic polyester-black.
- BUSHING : Brass, nickel plated.
- HOUSING : Stainless steel.
- TERMINAL/CONTACT : Brass , with silver or gold plated or gold over silver.
- SWITCH SUPPORT : Brass , tin plated.

Model No.	TYPE	
	AS-01	OFF

**KSD** 科斯达电子科技有限公司  
 SWITCH CONNECTOR KSD ELECTRONIC TECHNOLOGY Co., LTD  
 全球 互联零组件制造企业

TOLERANCE UNLESS OTHERWISE STATED :  
 Up to 5 ±0.2  
 Above 5 ~ 15 ±0.3  
 Above 15 ~ 30 ±0.4  
 Above 30 ~ 50 ±0.5  
 Angle ±0.3°

3RD. ANGEL'S

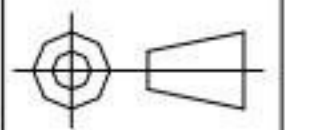

UNITS

MM

DRAWN BY:	DATE	MAT'L	TITLE	SWITCH
Frank Wu	10/18/11			
CHECKED BY:	DATE	FINISH	MODLE	TOGGLE PUSH SWITCH
Jacky Chen	10/18/11			
APPROVED BY:	DATE	SCALE	DWG NO.	AS-01B1A2
Tony Kao	10/18/11	1 : 1		
		SHEET NO.	PART NO.	AS-01B1A2
		1 of 1		

SIZE	A4
VER	A