

PRODUCT IMAGE

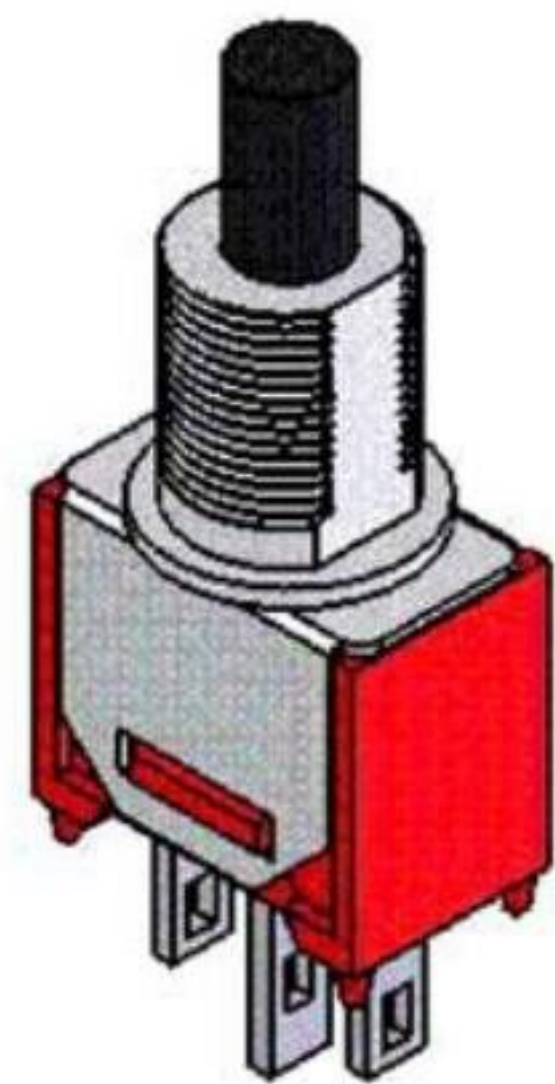

P.C.B MOUNTING

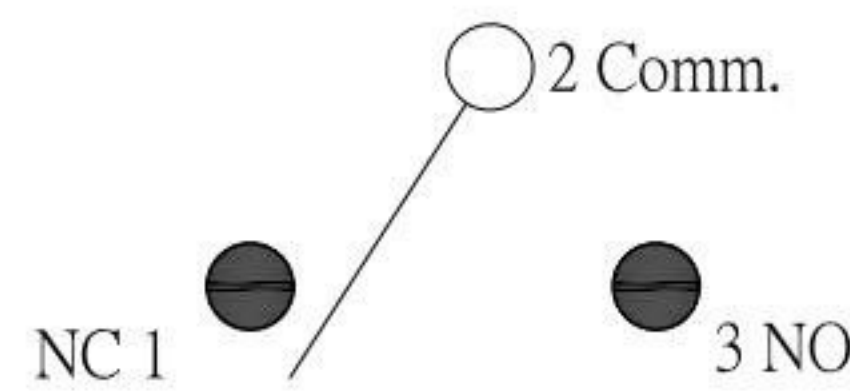

SPECIFICATIONS:

CONTACT RATING : 1 AMPS @ 120 V AC or 28 V DC.
 0.4 AMPS @ 20 V AC or DC
 ELECTRICAL LIFE : 30,000 make-and-break cycles at full load.
 CONTACT RESISTANCE : 20 mΩ max. initial @ 2-4 VDC
 100 mA , for both coin silver and gold plated contacts.
 INSULATION RESISTANCE : 1,000 MΩ min
 DIELETRIC STRENGTH : 1,000 V RAM @ sea level.
 OPERATING TEMPERTURE : -30°C to 130°C

MTAERIALS:

CASE : Dially phthalate (DAP)(UL-94V-0).
 PLUNGER : Thermoplastic polyester-black.
 BUSHING : Brass , nickel plated.
 HOUSING : Stainless steel.
 TERMINAL/CONTACT : Brass , witch silver or gold plated.
 or gold over silver
 SWITCH SUPPORT : Brass , tin plated.

Model No.	TYPE	
	AS-04	ON
Tem. Comm.	2-1	2-3

KSD 科斯达电子科技有限公司
 SWITCH CONNECTOR KSD ELECTRONIC TECHNOLOGY Co., LTD
 全球 互联零组件制造企业

TOLERANCE UNLESS OTHERWISE STATED :
 Up to 5 ±0.2
 Above 5 ~ 15 ±0.3
 Above 15 ~ 30 ±0.4
 Above 30 ~ 50 ±0.5
 Angle ±0.3'

3RD. ANGEL'S

UNITS MM

DRAWN BY:	DATE	MAT'L	TITLE	SWITCH
Frank Wu	11/07/11			
CHECKED BY:	DATE	FINISH	MODLE	Toggle PUSH SWITCH
Jacky Chen	11/07/11			
APPROVED BY:	DATE	SCALE	DWG NO.	AS-04
Tony Kao	11/07/11	1 : 1		
		SHEET NO.	PART NO.	AS-04
		1 of 1		

SIZE A4
 VER A