

P.C.B LAYOUT
TOP VIEW

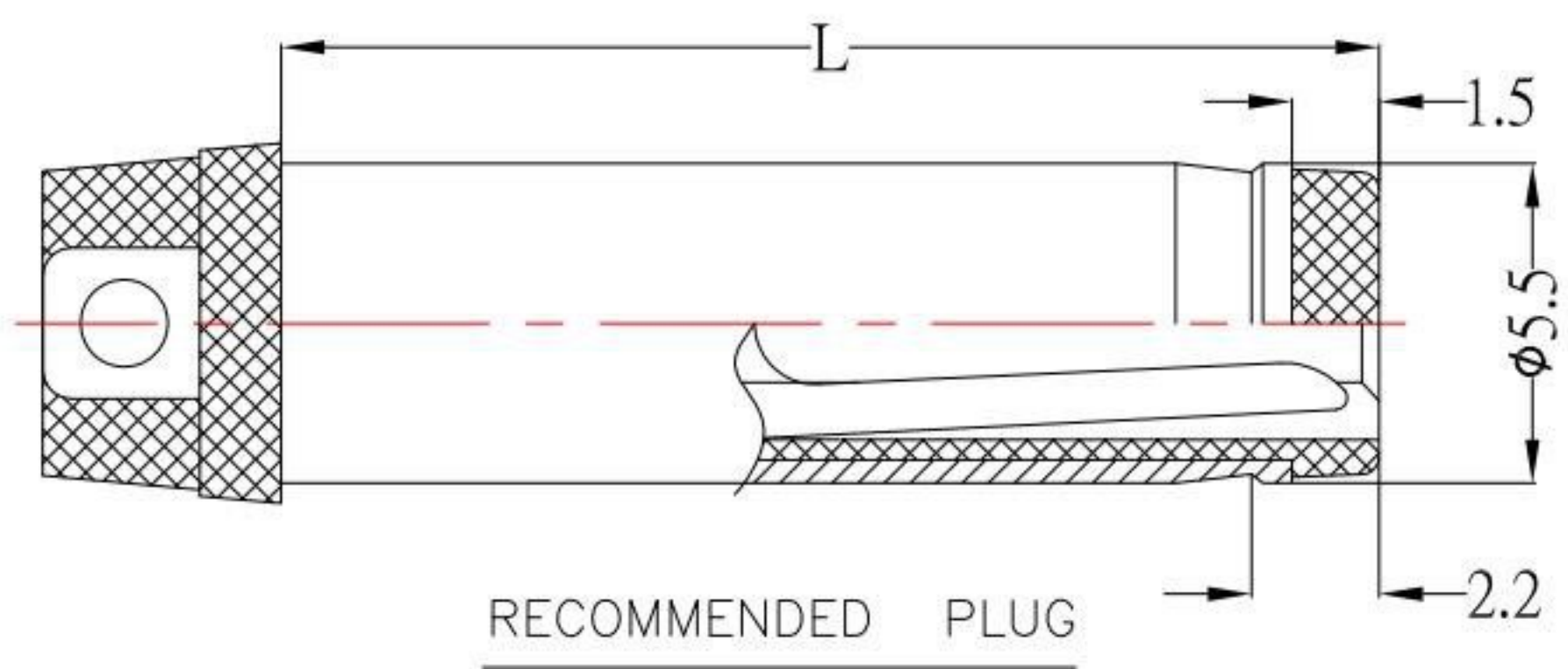

RECOMMENDED PLUG

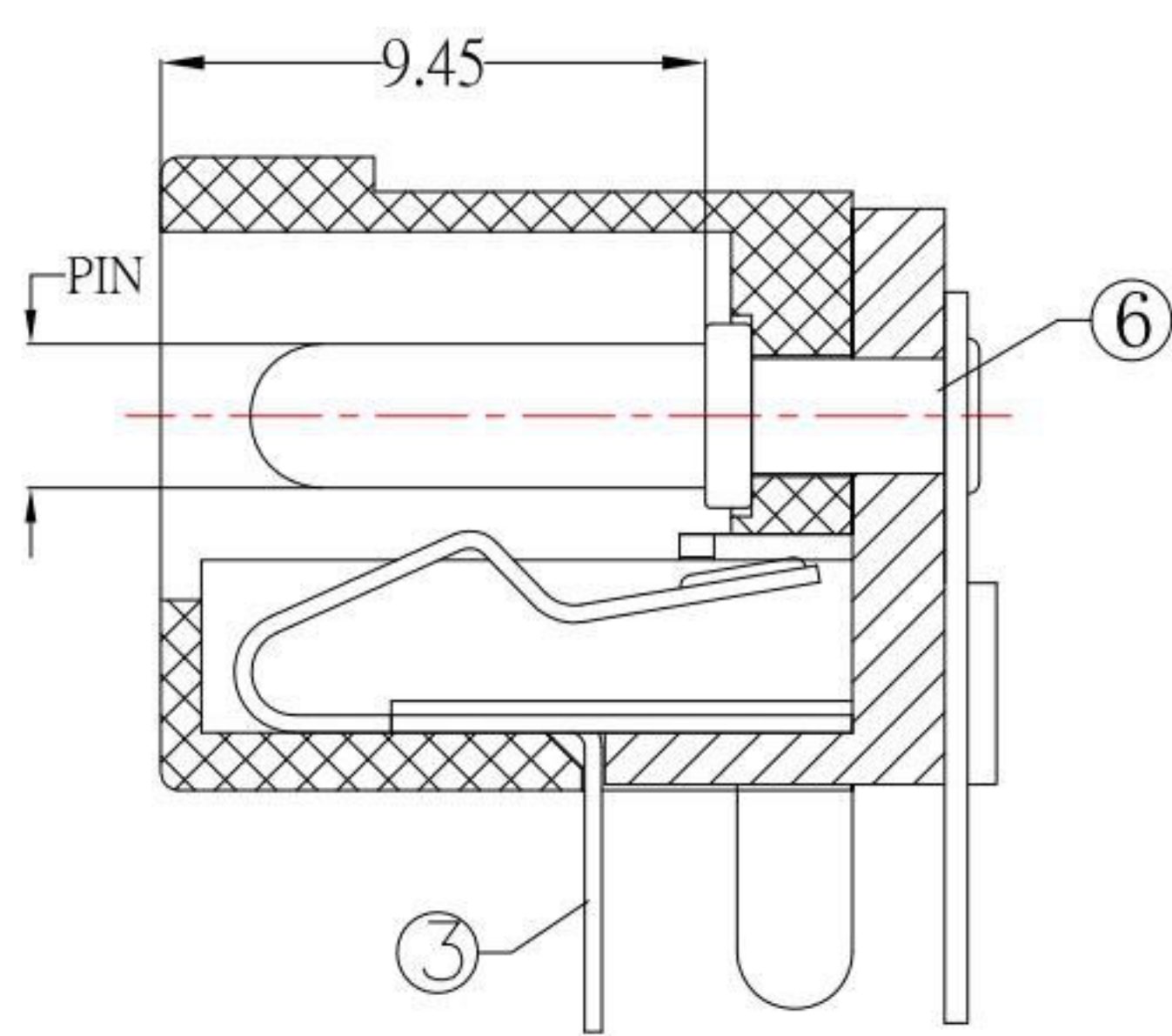

MODEL NO.	DC-002H-1-x-S124
SCHEMATIC	
CENTER PIN	$\phi 2.0$ mm $\phi 2.5$ mm

SPECIFICATION

- Rating : DC 12V , 6.0A
- Contact resistance : $\leq 30m\Omega$
- Insulation resistance : $\geq 100M\Omega$
- Withstand voltage : 500VAC
- Insertion and extraction force : 3-20N
- life test : 5,000 cycles

NO.	DESCRIPTION	QTY	MATERIAL	PLATING
⑥	PIN	1	BRASS	Ni-Plating
⑤	CURVE PIECE	1	BRASS	Sn-Plating
④	FLAT PIECE	1	BRASS	Sn-Plating
③	SPRING PIECE	1	PHOSPHOR BRONZE	Sn-Plating
②	COVER	1	LCP	
①	HOUSING	1	LCP	

KSD 科斯达电子科技有限公司
 SWITCH CONNECTOR KSD ELECTRONIC TECHNOLOGY Co., LTD
 全球 互联零组件制造企业

TOLERANCE UNLESS OTHERWISE STATED:
 Up to 5 ± 0.2
 Above 5 ~ 15 ± 0.3
 Above 15 ~ 30 ± 0.4
 Above 30 ~ 50 ± 0.5
 Angle $\pm 0.3^\circ$

3RD. ANGEL'S

UNITS MM

DRAWN BY:	DATE	MAT'L	TITLE	JACK
Jack Lu	04/06/21			
CHECKED BY:	DATE	FINISH	MODLE	DC JACK DIP TYPE
Jacky Chen	04/06/21			
APPROVED BY:	DATE	SCALE	DWG NO.	DC-002H-1-x-S124
Tony Kao	04/06/21	1 : 1		
		SHEET NO.	PART NO.	DC-002H-1-x-S124
		1 of 1		

ITEM NO.	DESCRIPTION	DRAWN	DATE
3	更新PCB LAYOUT外型孔	Jack	040621
2	新增尺寸	Jack	030620
1	新增尺寸	Jack	041018

SIZE A4
VER R3