

P.C.B LAYOUT
TOP VIEW

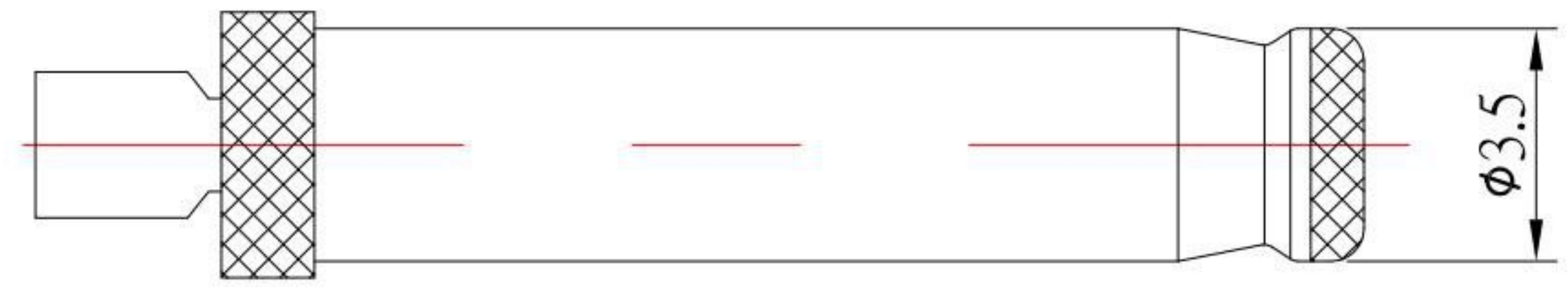
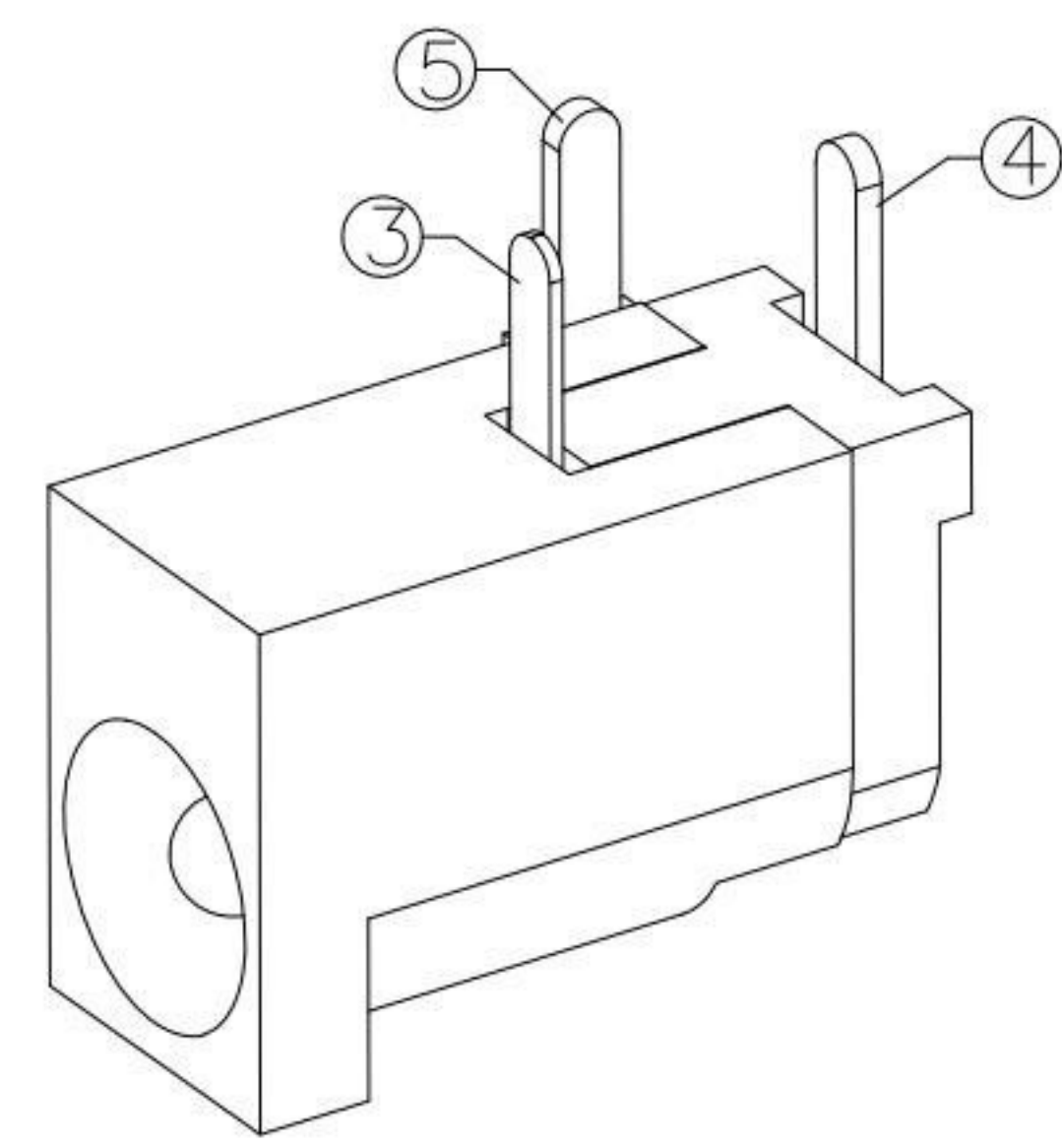

RECOMMENDED PLUG

MODEL NO.	DC-009-1-x-S124
SCHEMATIC	
CENTER PIN	φ1.0 mm
	φ1.3 mm

SPECIFICATION

1. Rating : DC 30V 1.5A ;
2. Contact resistance : ≤30mΩ ;
3. Insulation resistance : ≥100MΩ ;
4. Withstand voltage : 500VAC ;
5. Insertion and extraction force : 3-20N;
6. life test : 5,000 cycles °

NO.	DESCRIPTION	QTY	MATERIAL	FINISH
6	PIN	1	BRASS	Ni-PLATED
5	CURVE PIECE	1	BRASS	Sn-PLATED
4	FLAT PIECE	1	BRASS	Sn-PLATED
3	SPRING	1	SUS	Sn-PLATED
2	COVER	1	PBT	
1	HOUSING	1	PBT	

KSD 科斯达电子科技有限公司
SWITCH CONNECTOR KSD ELECTRONIC TECHNOLOGY Co., LTD
全球 互联零组件制造企业

TOLERANCE UNLESS OTHERWISE STATED :	Up to 5 ±0.2	3RD. ANGEL'S	UNITS	MM
	Above 5 ~ 15 ±0.3			
	Above 15 ~ 30 ±0.4			
	Above 30 ~ 50 ±0.5			
	Angle			±0.3°

ITEM NO.	DESCRIPTION	DRAWN	DATE
3	更新樣式	Lan	062019
2	更新圖面	Jack	112917
1	更新為A0版	Jack	100516

DRAWN BY:	DATE	MAT'L	TITLE	JACK
Jack Lu	06/20/19			
CHECKED BY:	DATE	FINISH	MODLE	DC JACK
Jacky Chen	06/20/19			
APPROVED BY:	DATE	SCALE	DWG NO.	DC-009-1-x-S124
Tony Kao	06/20/19	1 : 1		
		SHEET NO.	PART NO.	DC-009-1-x-S124
		1 of 1		

SIZE	A4
VER	R3