

P.C.B LAYOUT MOUNTING PATTERN  
(TOP-VIEW)

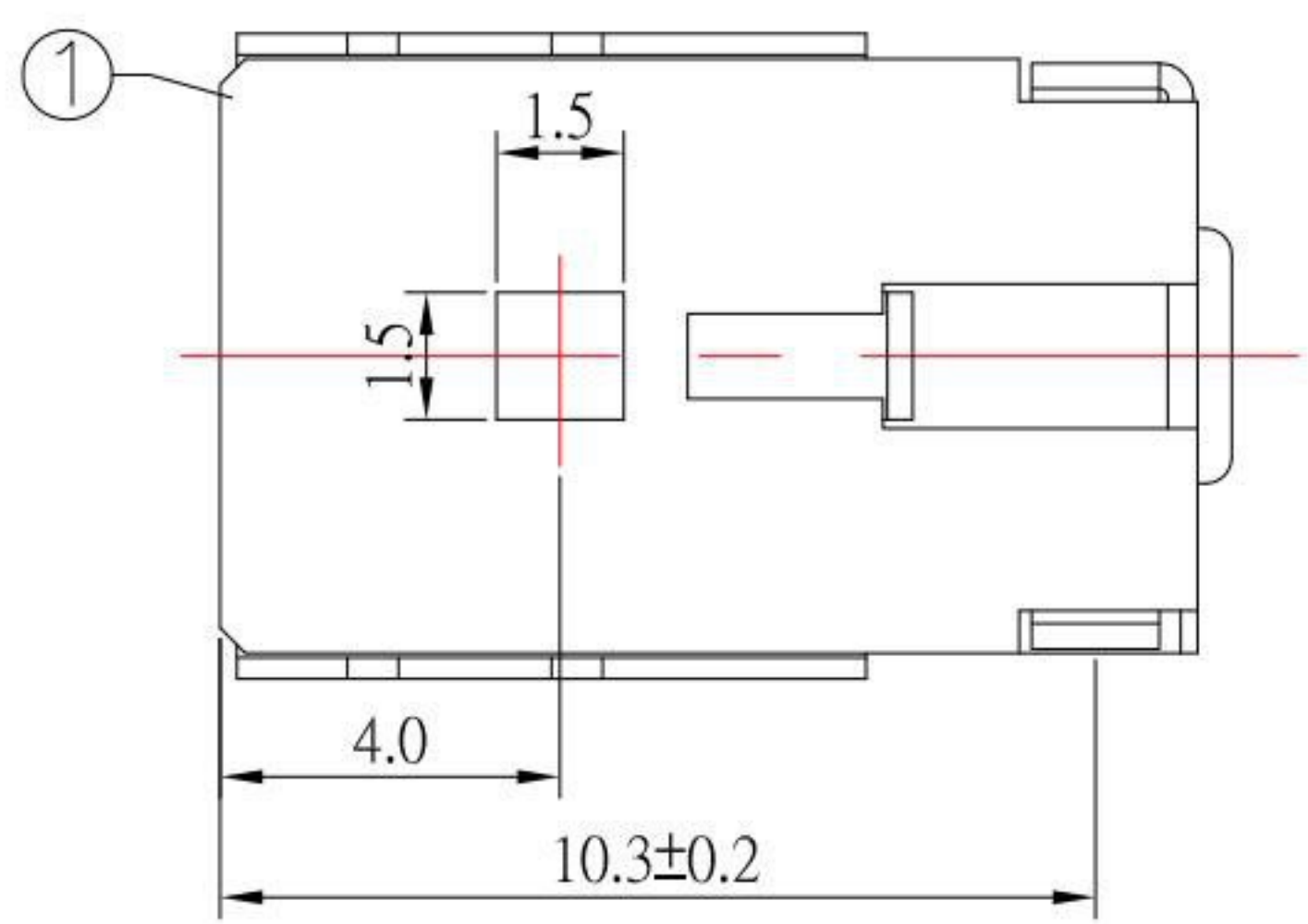

MODEL NO.	DC-038S-x-S124
SCHEMATIC	4(5) 3 2
CENTER PIN	φ 2.0mm φ 2.5mm

**SPECIFICATION**

- 1.Rating : DC 30V 2.0A ;
- 2.Contact resistance : ≤ 30mΩ ;
- 3.Insulation resistance : ≥ 100MΩ ;
- 4.Withstand voltage : 500VAC ;
- 5.Insertion and extraction force : 3-20N;
- 6.life test : 5,000 cycles °

NO.	DESCRIPTION	QTY	MATERIAL	PLATING
⑥	Coat	1	Brass	Ni-Plating
⑤	Pin	1	Brass	Ni-Plating
④	Contact Foot	1	Brass	Ag-Plating
③	Curve Piece	1	Brass	Ag-Plating
②	Spring	1	SUS	Ag-Plating
①	Housing	1	PPT	

**KSD** 科斯达电子科技有限公司  
SWITCH CONNECTOR KSD ELECTRONIC TECHNOLOGY Co., LTD  
全球 互联零组件制造企业

TOLERANCE UNLESS OTHERWISE STATED :	Up to 5 ±0.2 Above 5 ~ 15 ±0.3 Above 15 ~ 30 ±0.4 Above 30 ~ 50 ±0.5 Angle ±0.3°	3RD. ANGEL'S	UNITS	MM
-------------------------------------	--	--------------	-------	----

DRAWN BY:	DATE	MAT'L	TITLE	JACK
Jack Lu	09/10/20	FINISH	MODLE	DC JACK
CHECKED BY:	DATE	SCALE	DWG NO.	DC-038S-x-S124
Jacky Chen	09/10/20	1 : 1	PART NO.	DC-038S-x-S124
APPROVED BY:	DATE	SHEET NO.	1 of 1	
Tony Kao	09/10/20			

ITEM NO.	DESCRIPTION	DRAWN	DATE
1	更新樣式	Jack	091020