

P.C.B LAYOUT MOUNTING PATTERN
(TOP VIEW)

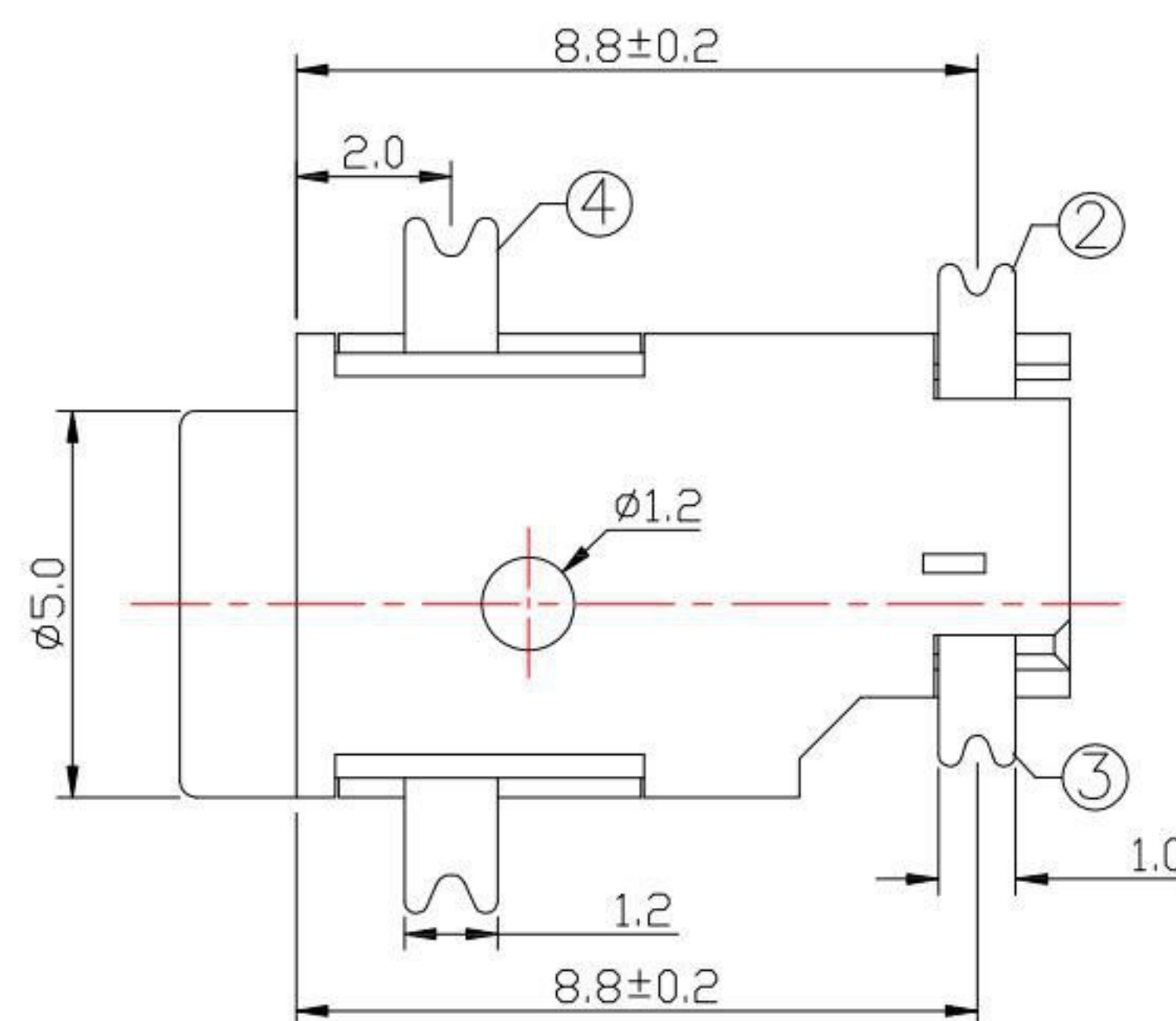

SPECIFICATION

1. Rating : DC 30V , 2.0A
2. Contact resistance : $\leq 30m\Omega$
3. Insulation resistance : $\geq 100M\Omega$
4. Withstand voltage : 500VAC
5. Insertion and extraction force : 2-20N
6. life test : 5,000 cycles

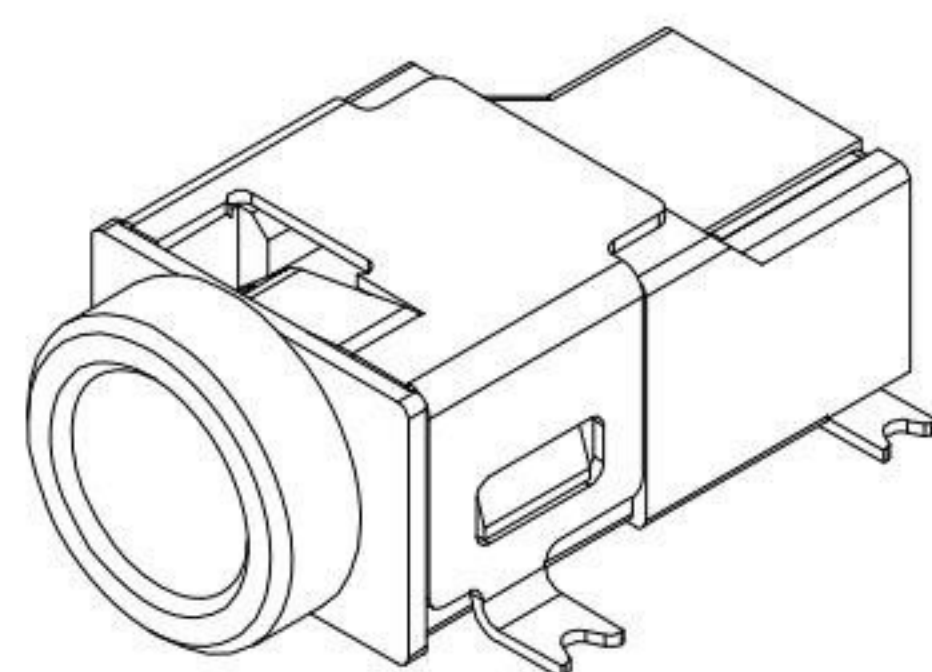
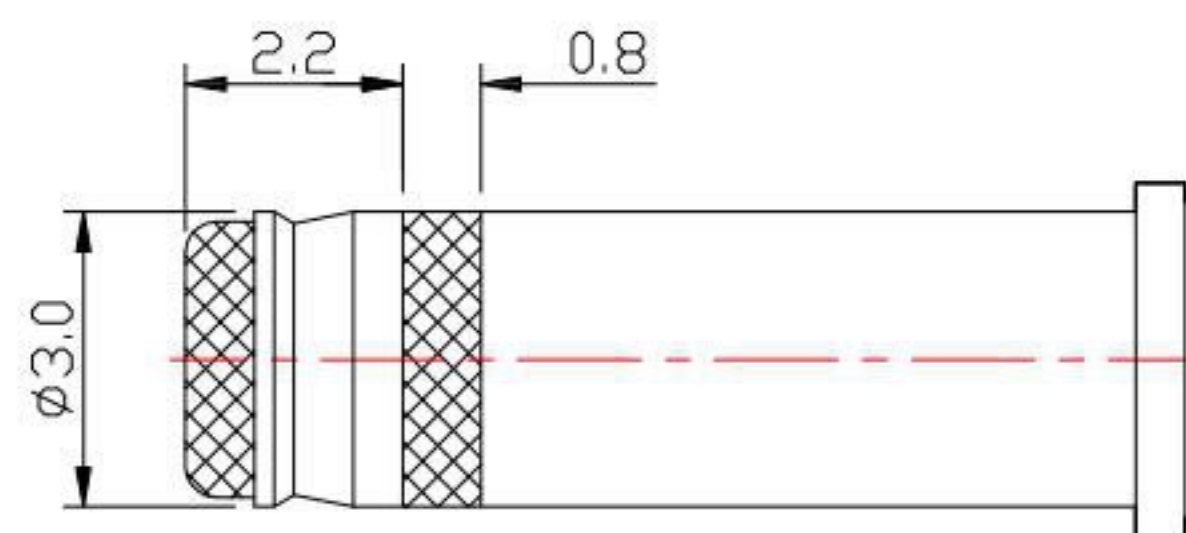

PLUG

MODEL NO.	DC-043D-1.0
SCHEMATIC	

NO.	DESCRIPTION	QTY	MATERIAL	REMARK
④	CONTACT FOOT	1	Phosphor Bronze	Au-Plating
③	PIN	1	Phosphor Bronze	Au-Plating
②	SPRING PIECE	1	Phosphor Bronze	Au-Plating
①	HOUSING	1	PA9T	

DRAWN BY:	DATE	MAT'L	TITLE	JACK
Jack Lu	01/05/18			
CHECKED BY:	DATE	FINISH	MODLE	DC JACK
Jacky Chen	01/05/18			
APPROVED BY:	DATE	SCALE	DWG NO.	DC-043D-1.0-S124
Tony Kao	01/05/18	1 : 1		
		SHEET NO.	PART NO.	DC-043D-1.0-S124
		1 of 1		

KSD 科斯达电子科技有限公司
SWITCH CONNECTOR KSD ELECTRONIC TECHNOLOGY Co., LTD
全球 互联零组件制造企业

TOLERANCE UNLESS OTHERWISE STATED:	Up to 5 ±0.2	3RD. ANGEL'S	UNITS	MM
	Above 5 ~ 15 ±0.3			
	Above 15 ~ 30 ±0.4			
	Above 30 ~ 50 ±0.5			
	Angle ±0.3°			

ITEM NO.	DESCRIPTION	DRAWN	DATE