

P.C.B LAYOUT
TOP VIEW

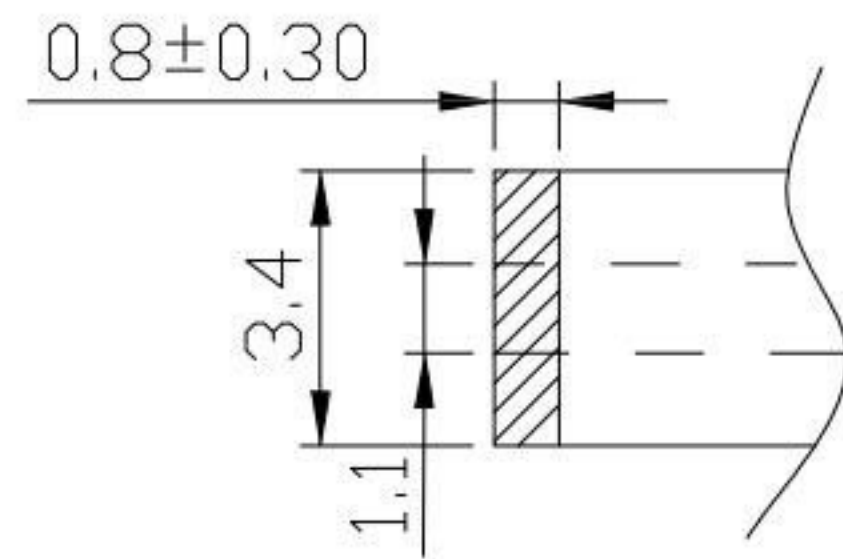
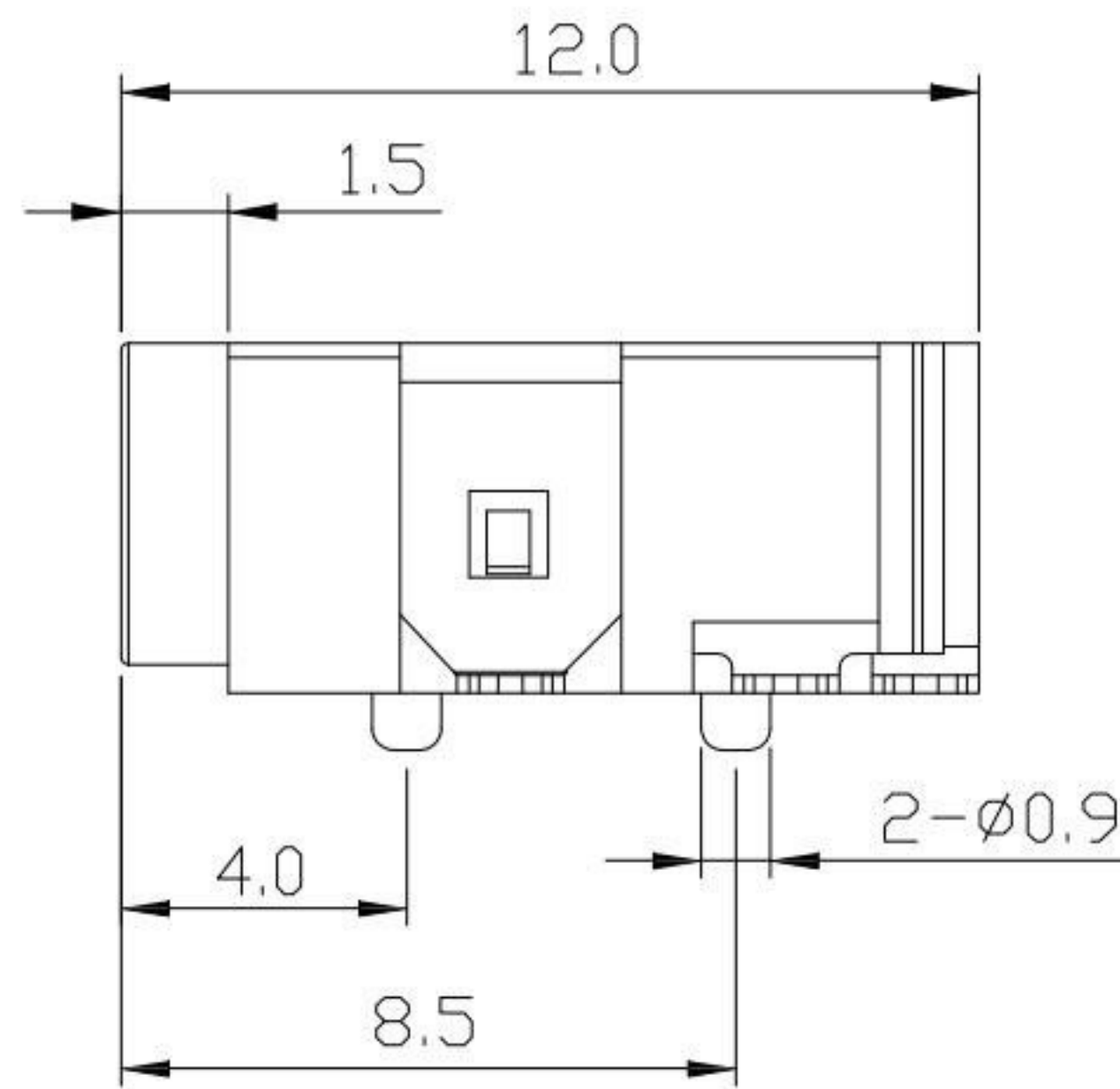
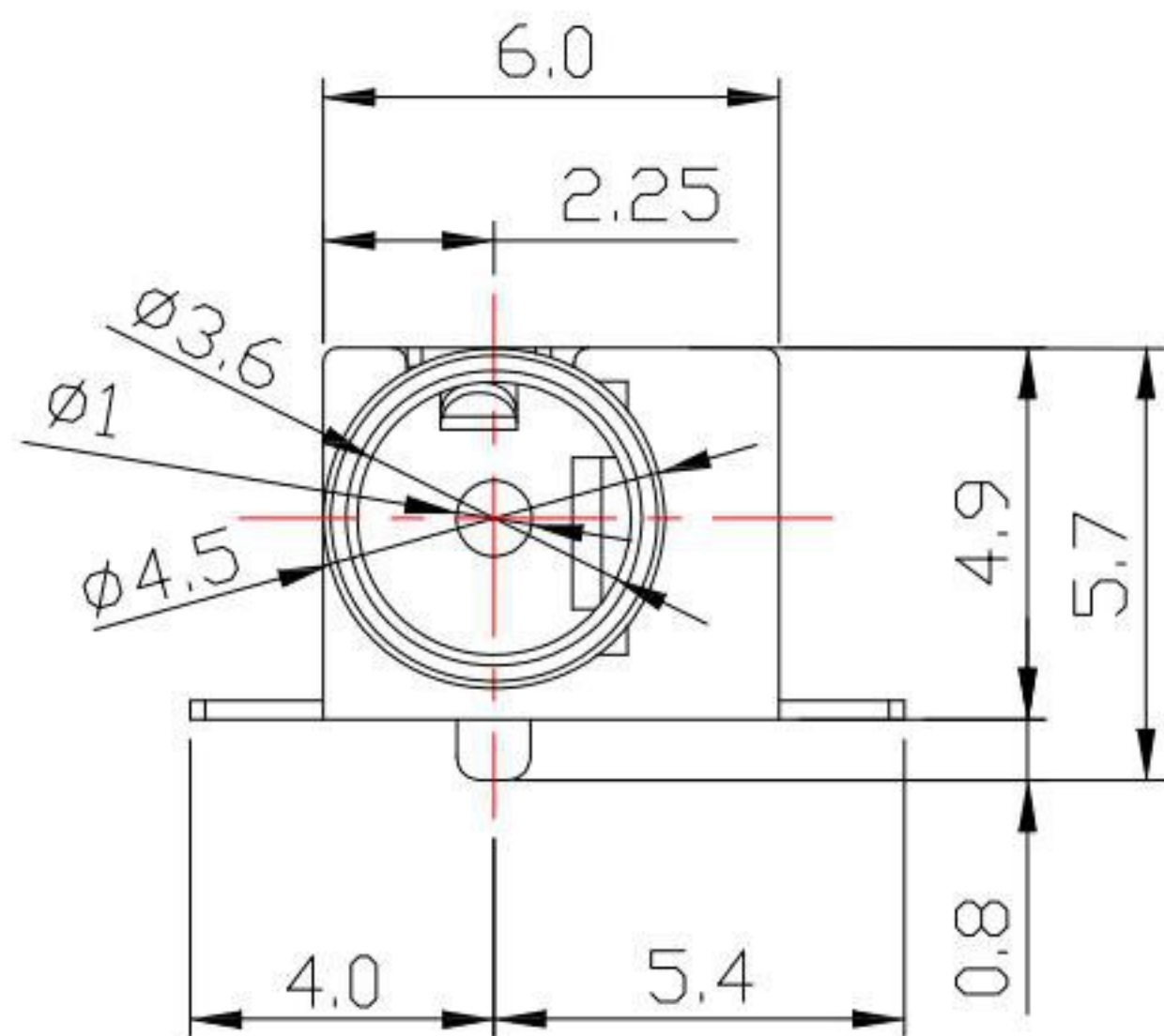

MODEL NO.	DC-053D-1.0
SCHEMATIC	

NO.	DESCRIPTION	QTY	MATERIAL	PLATING
5	HOUSING	1	PA9T	
4	TRRRMINAL#4	1	BRASS	Au-Plating
3	TRRRMINAL#3	1	PHOSPHOR BRONZE	Au-Plating
2	TRRRMINAL#2	1	PHOSPHOR BRONZE	Au-Plating
1	TRRRMINAL#1	1	BRASS	Au-Plating

KSD 科斯达电子科技有限公司
 SWITCH CONNECTOR KSD ELECTRONIC TECHNOLOGY Co., LTD
 全球 互聯零組件製造企業

TOLERANCE UNLESS OTHERWISE STATED:
 Up to 5 ±0.2
 Above 5 ~ 15 ±0.3
 Above 15 ~ 30 ±0.4
 Above 30 ~ 50 ±0.5
 Angle ±0.3°

3RD. ANGLE'S

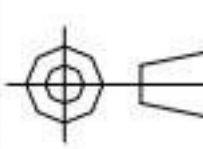

UNITS

MM

DRAWN BY: Jack Lu
 CHECKED BY: Jacky Chen
 APPROVED BY: Tony Kao

DATE: 02/21/22
 DATE: 02/21/22
 DATE: 02/21/22

MAT'L		TITLE	JACK
FINISH		MODLE	DC JACK
SCALE	1:1	DWG NO.	DC-053D-1.0-S187
SHEET NO.	1 of 1	PART NO.	DC-053D-1.0-S187

SIZE: A4
 VER: R

ITEM NO.	DESCRIPTION	DRAWN	DATE