

SPECIFICATION

- 1. Rating : 0.5A , 30VDC ;
- 2. Contact resistance : $\leq 50m\Omega$;
- 3. Insulation resistance : $\geq 100M\Omega$;
- 4. Withstand voltage : 500VAC ;
- 5. life test : 5,000 cycles °
- 6. Connector mating forces : 20N (2.04Kgf) Max ;
- 7. Connector unmating forces : 2N(0.204Kgf) Min °

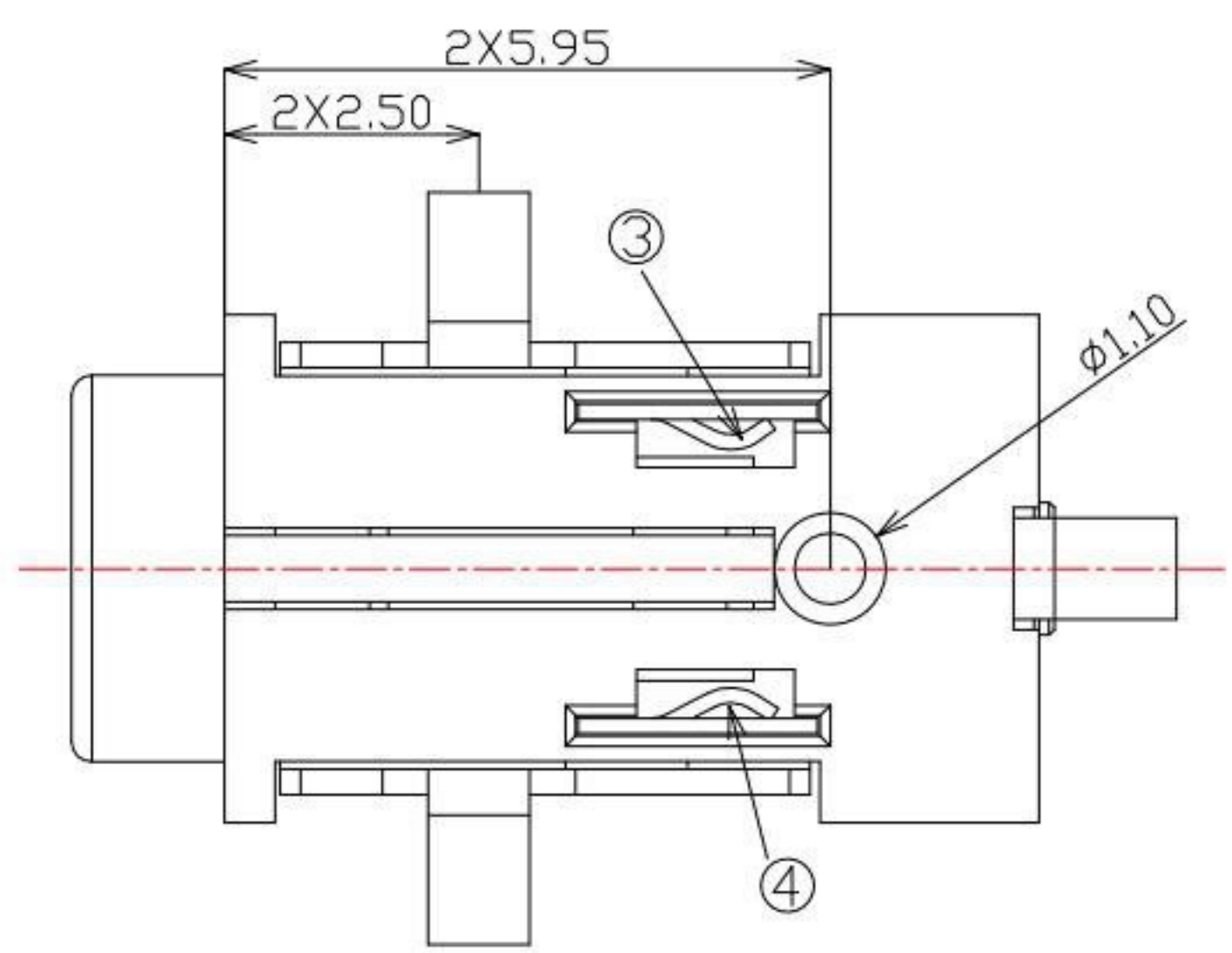
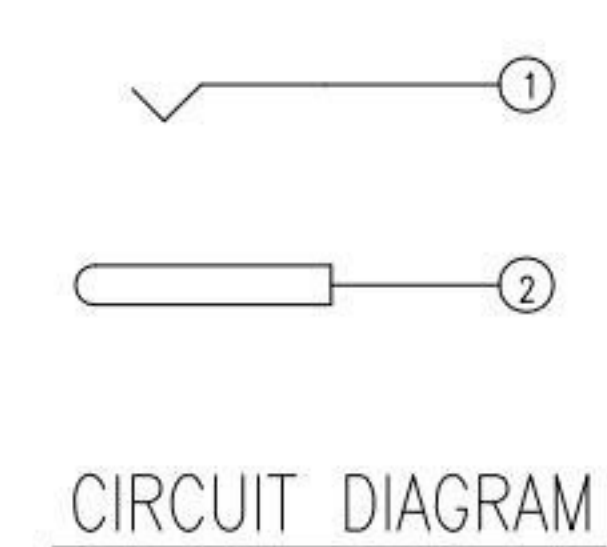

ITEM	NAME	Q'TY	MATERIAL	DESCRIPTION
7	MYLAR	1		
6	HOUSING	1	HTN	
5	CONTACT E	1	PHOSPHOR BRONZE	GOLD PLATED
4	CONTACT D	1	STAINLESS STEEL	
3	CONTACT C	1	STAINLESS STEEL	
2	CONTACT B	1	BRASS	GOLD PLATED
1	CONTACT A	1	PHOSPHOR BRONZE	GOLD PLATED

KSD 科斯达电子科技有限公司
 SWITCH CONNECTOR KSD ELECTRONIC TECHNOLOGY Co., LTD
 全球 互联零组件制造企业

TOLERANCE UNLESS OTHERWISE STATED :
 Up to 5 ±0.2
 Above 5 ~ 15 ±0.3
 Above 15 ~ 30 ±0.4
 Above 30 ~ 50 ±0.5
 Angle ±0.3°

3RD. ANGEL'S

UNITS MM

DRAWN BY:	DATE	MAT'L	TITLE	JACK
Jack Lu	08/04/15			
CHECKED BY:	DATE	FINISH	MODLE	DC JACK
Jacky Chen	08/04/15			
APPROVED BY:	DATE	SCALE	DWG NO.	DC-063DS-S119
Tony Kao	08/04/15	1:1		
		SHEET NO.	PART NO.	DC-063DS-S119
		1 of 1		

ITEM NO.	DESCRIPTION	DRAWN	DATE
3	新增SPEC	Jack	080415
2	更新材質	Jack	042214
1	圖面更新	FrankWu	112811