

P.C.B. LAYOUT  
(VIEW FROM THE DIRECTION A)

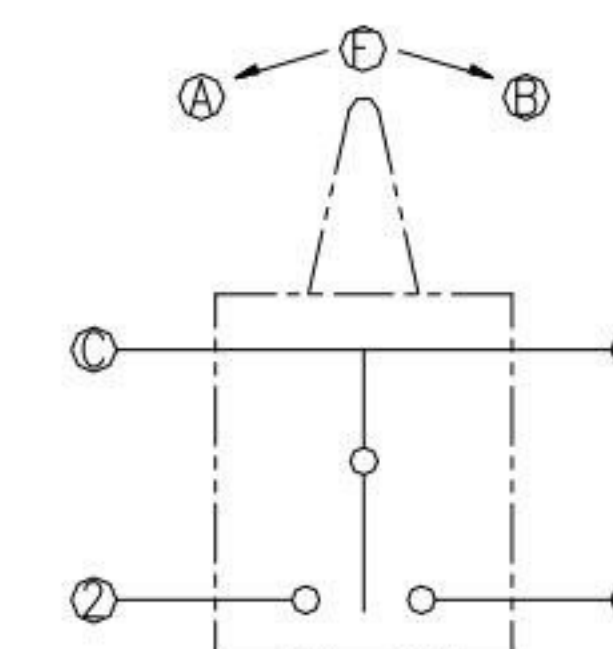

CIRCUIT DIAGRAM

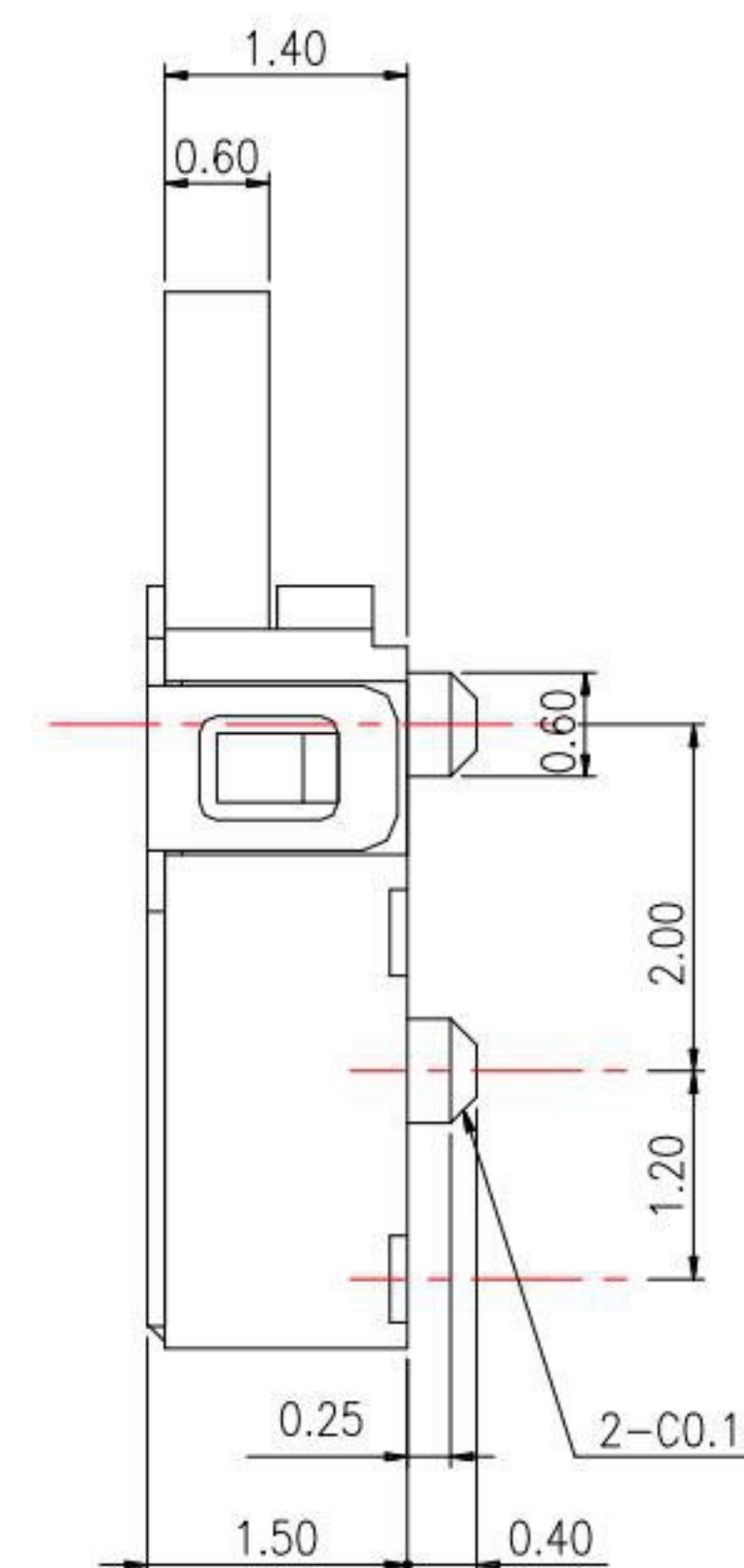
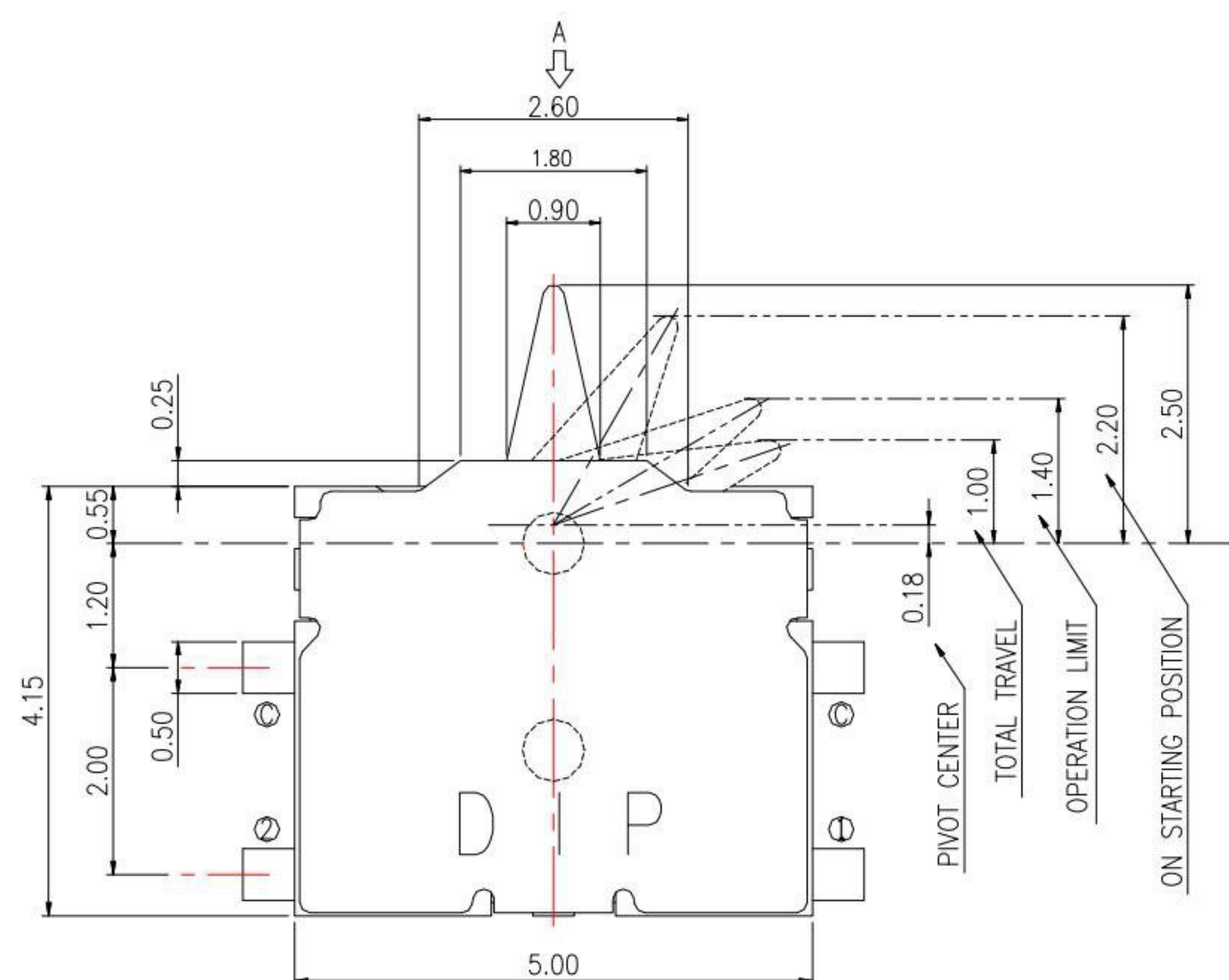

SPECIFICATIONS

- 1.RATING: DC 5V,10mA
- 2.CONTACT RESISTANCE: 500mΩ Max.
- 3.INSULATION RESISTANCE: 100MΩ Min.
- 4.WITHSTAND VOLTAGE: 100VAC / minute.
- 5.OPERATING FORCE: 30gf Max
- 6.STOKE: 1.5±0.3mm
- 7.OPERATING LIFE CYCLE: 100,000 CYCLES.

**KSD** 科斯达电子科技有限公司  
SWITCH CONNECTOR KSD ELECTRONIC TECHNOLOGY Co., LTD  
全球 互联零组件制造企业

TOLERANCE UNLESS OTHERWISE STATED:  
Up to 5 ±0.2  
Above 5 ~ 15 ±0.3  
Above 15 ~ 30 ±0.4  
Above 30 ~ 50 ±0.5  
Angle ±0.3°

3RD. ANGEL'S

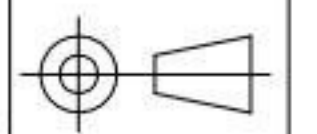

UNITS MM

DRAWN BY: Jack Lu DATE: 08/20/13  
CHECKED BY: Jacky Chen DATE: 08/20/13  
APPROVED BY: Tony Kao DATE: 08/20/13

MAT'L		TITLE	SWITCH
FINISH		MODLE	DETECTOR SWITCH
SCALE	1 : 1	DWG NO.	DS-C30E-HF-S008
SHEET NO.	1 of 1	PART NO.	DS-C30E-HF-S008
		SIZE	A4
		VER	R

ITEM NO.	DESCRIPTION	DRAWN	DATE