

RECOMMENDED P.C.B. LAYOUT

NOTE:

1.MATERIAL:

- 1.1 HOUSING: LCP, BLACK
- 1.2 CONTACT: BRASS
- 1.3 SHEEL: BRASS

2.PLATING :

- 2.1 CONTACT: PLATED GOLD IN MATING AREA ;
TIN PLATED ON SOLDER BALLS ;
NICKEL UNDER PLATED OVERALL
- 2.2 SHELL: NICKEL UNDER PLATED SURFACE LAYER

3.ELECTRICAL:

- 3.1 RATING: 40V , 0.5A
- 3.2 CONTACT RESISTANCE: 30 mΩ Max
- 3.3 INSULATION RESISTANCE: 100MΩ Min
- 3.4 DIELECTRIC WITHSTANDING VOLTAGE: 500V AC
- 3.5 OPERATING TEMPERATURE: -25°C~ 85°C

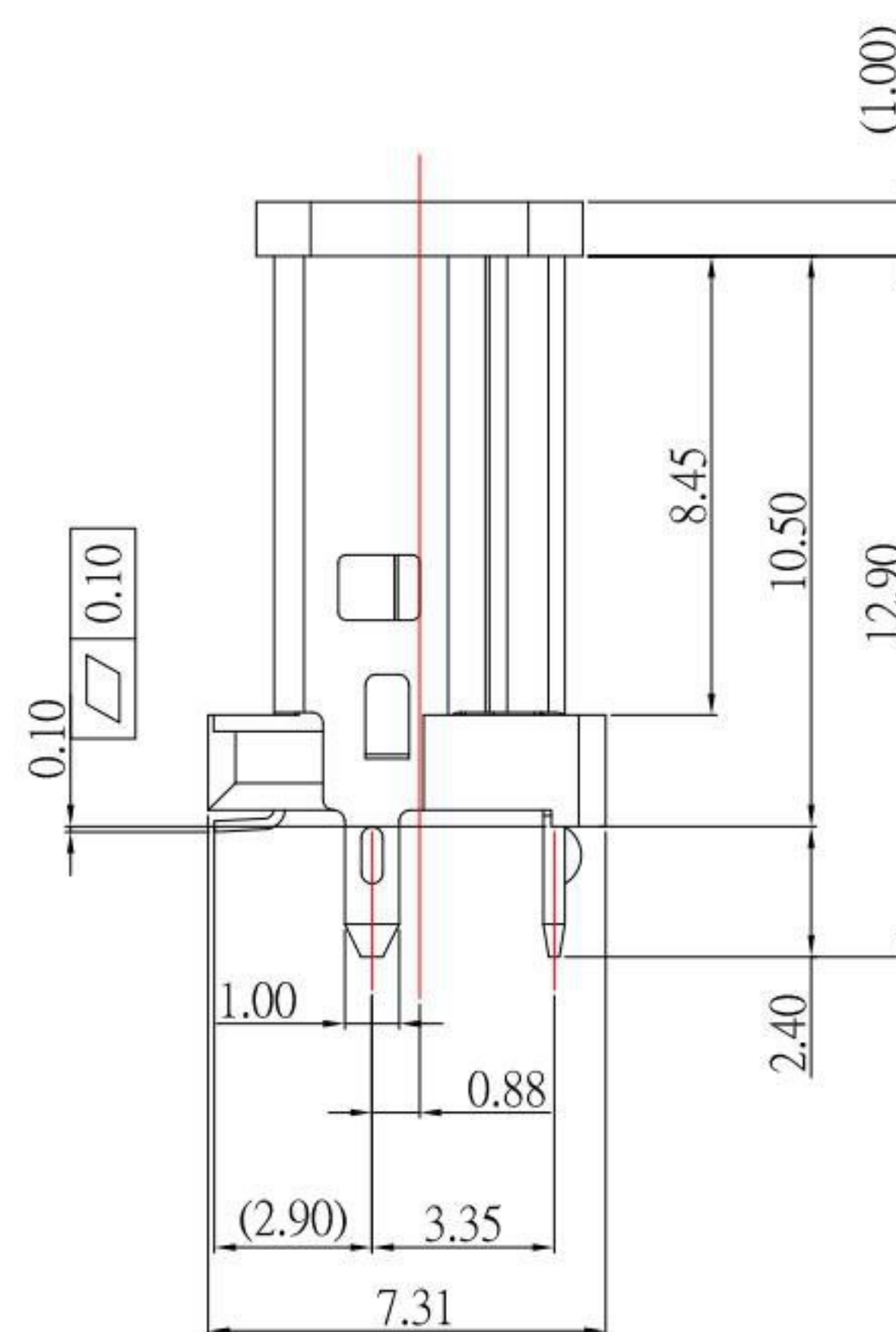
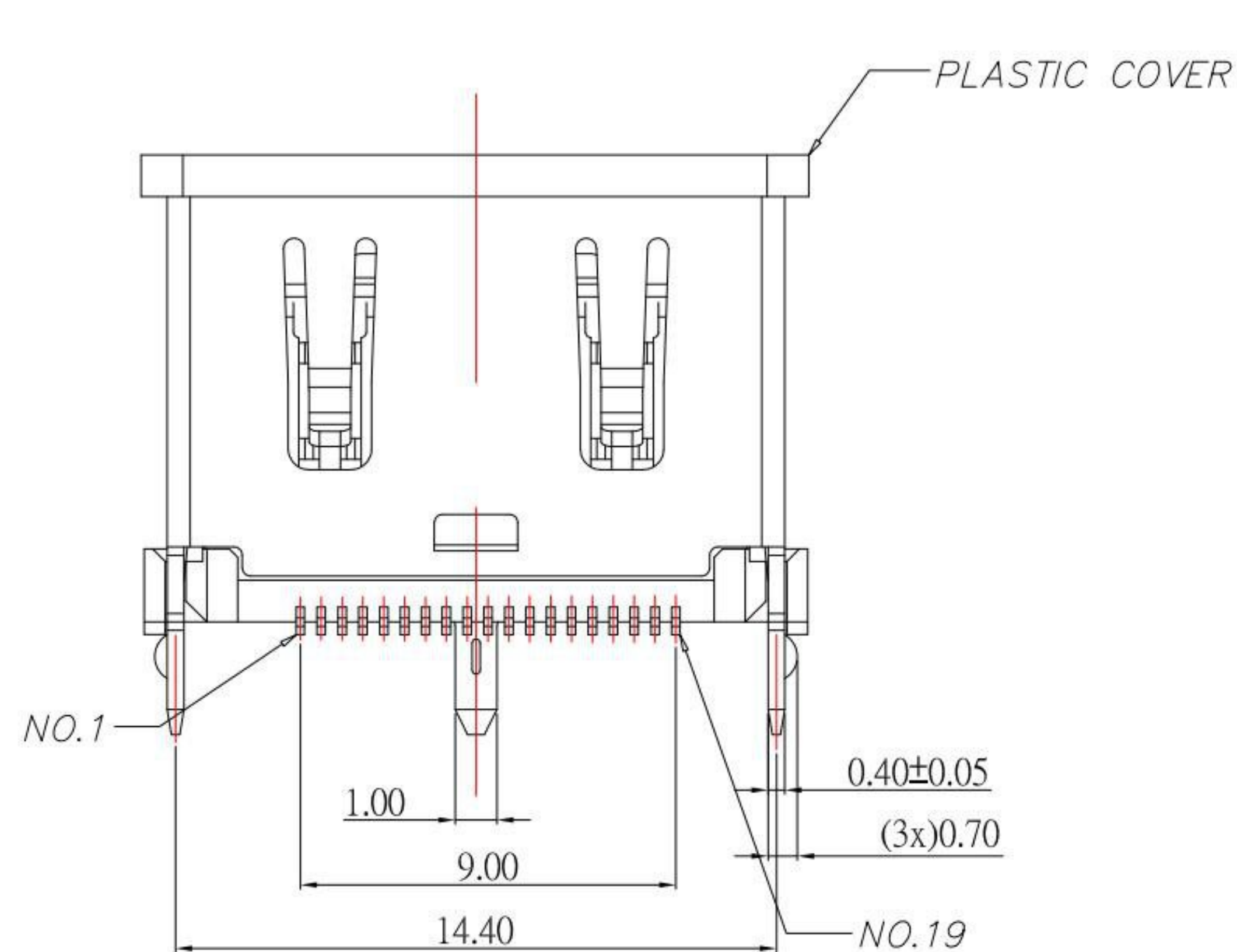

KSD 科斯达电子科技有限公司
 SWITCH CONNECTOR KSD ELECTRONIC TECHNOLOGY Co., LTD
 全球 互联零组件制造企业

TOLERANCE UNLESS OTHERWISE STATED:
 Up to 5 ±0.2
 Above 5 ~ 15 ±0.3
 Above 15 ~ 30 ±0.4
 Above 30 ~ 50 ±0.5
 Angle ±0.3°

3RD. ANGEL'S

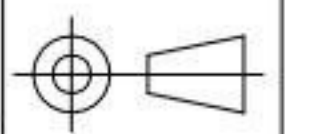

UNITS MM

DRAWN BY: Jack Lu
 DATE: 04/10/23
 CHECKED BY: Jacky Chen
 DATE: 04/10/23
 APPROVED BY: Tony Kao
 DATE: 04/10/23

MAT'L		TITLE	CONNECTOR
FINISH		MODLE	HDMI 2.1 AF 立式 SMT H10.5
SCALE	1 : 1	DWG NO.	HD2-19P-VS1-S165
SHEET NO.	1 of 1	PART NO.	HD2-19P-VS1-S165

1	更新圖面	Jack	041023
ITEM NO.	DESCRIPTION	DRAWN	DATE

SIZE A4
 VER R