

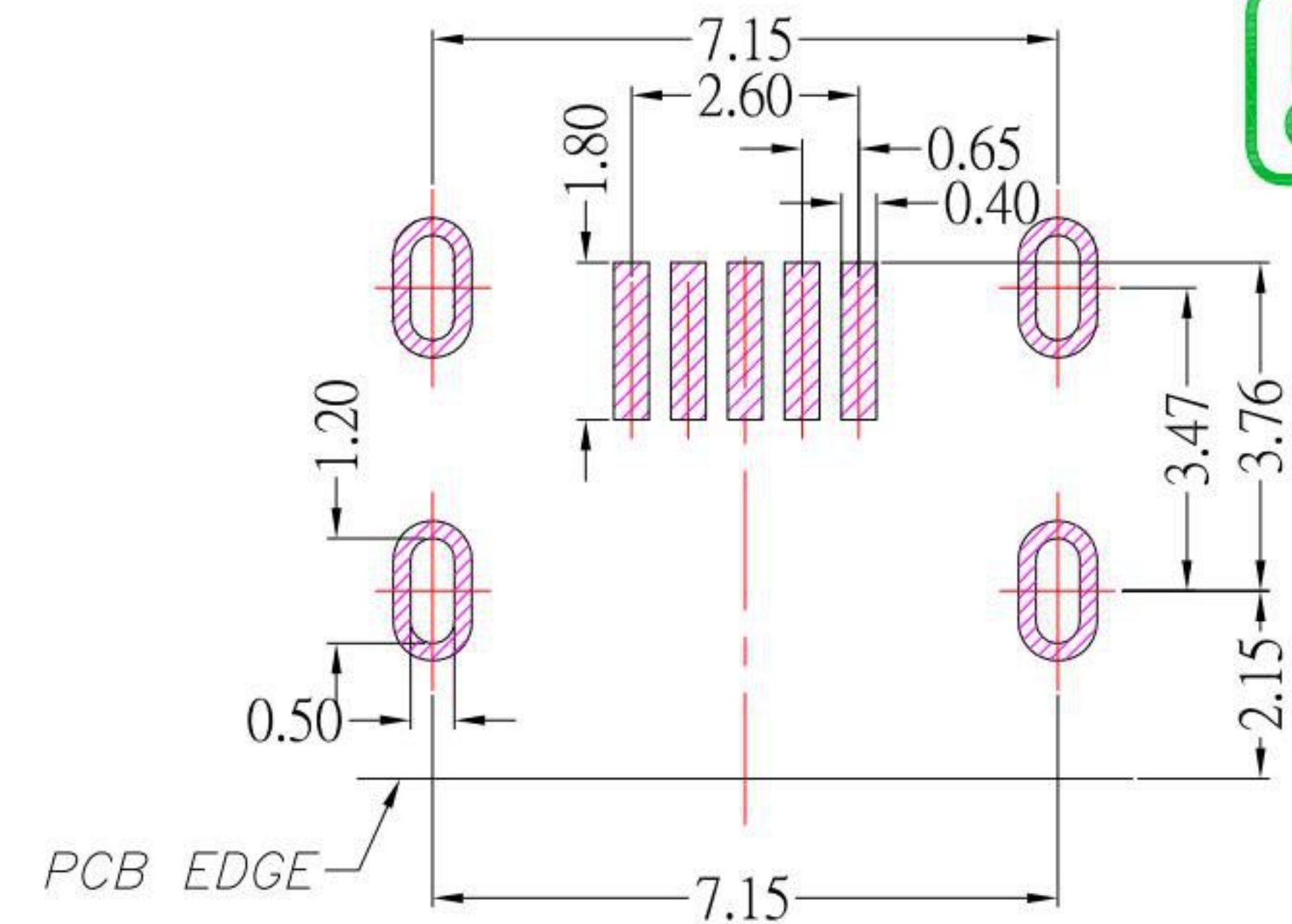

MRUSB-5B-D17xx-S347

Shell Material : SHELL 鍍層:	
Blank : BRASS	TN
A : SUS	NI

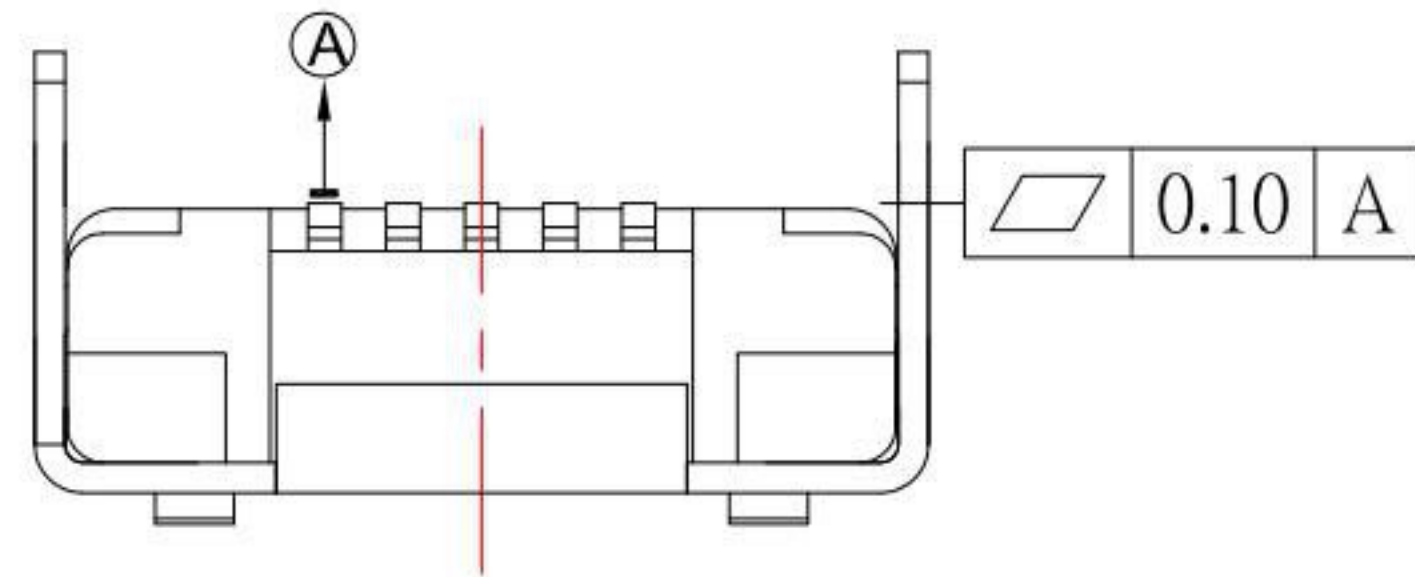

P.C.B LAYOUT MOUNTING PATTERN

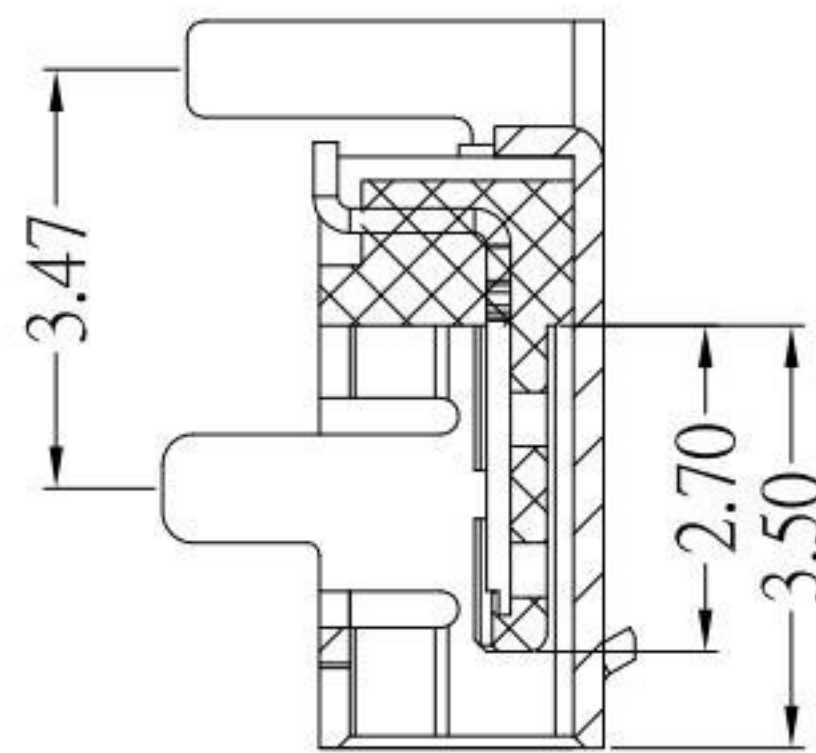

SECTION A-A

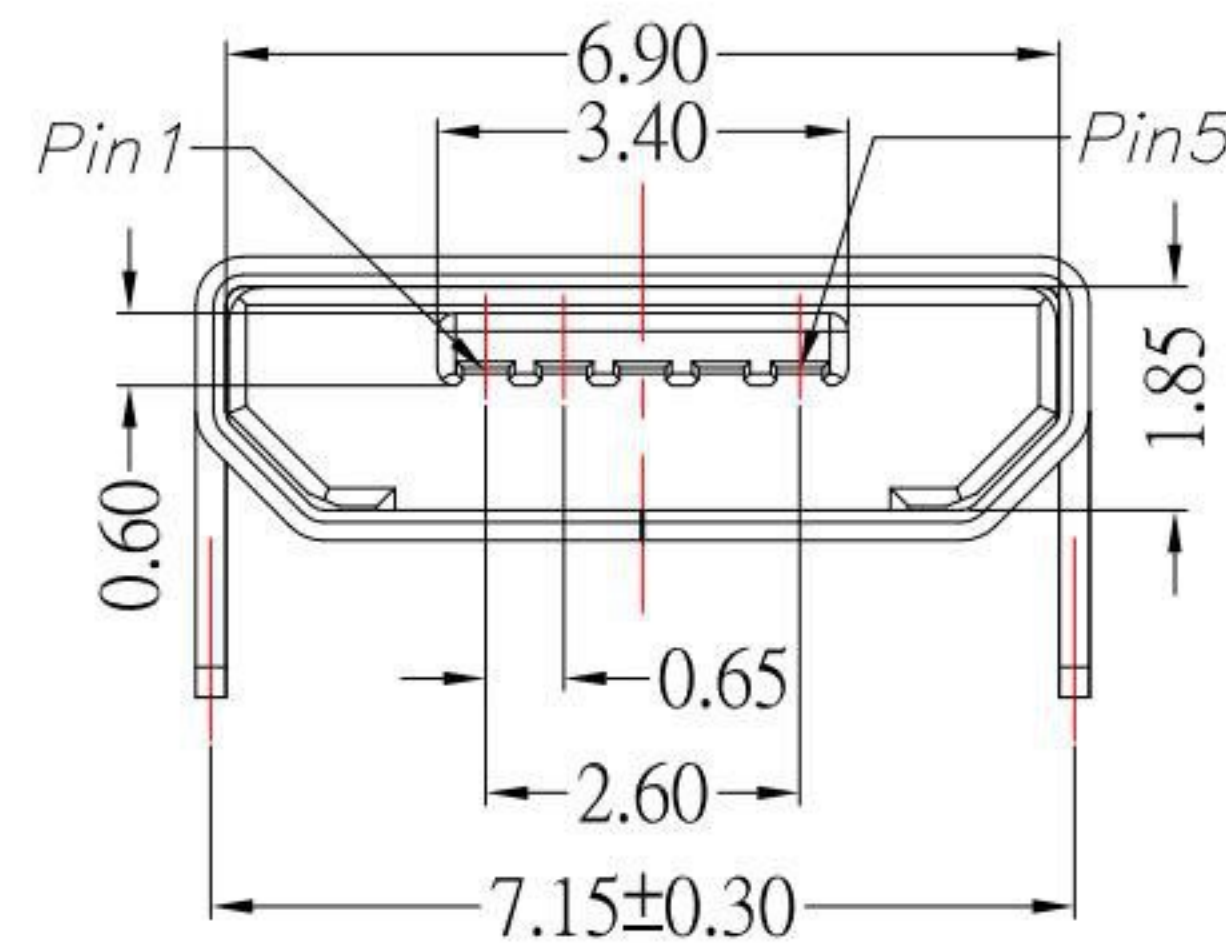
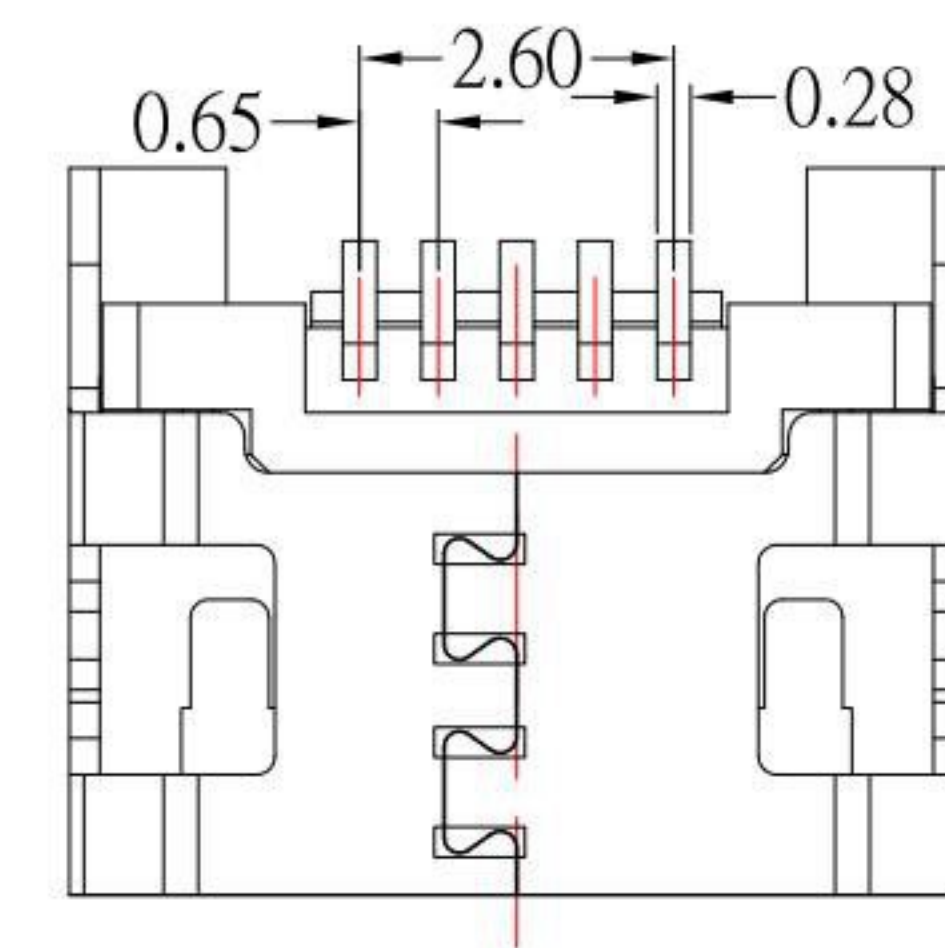
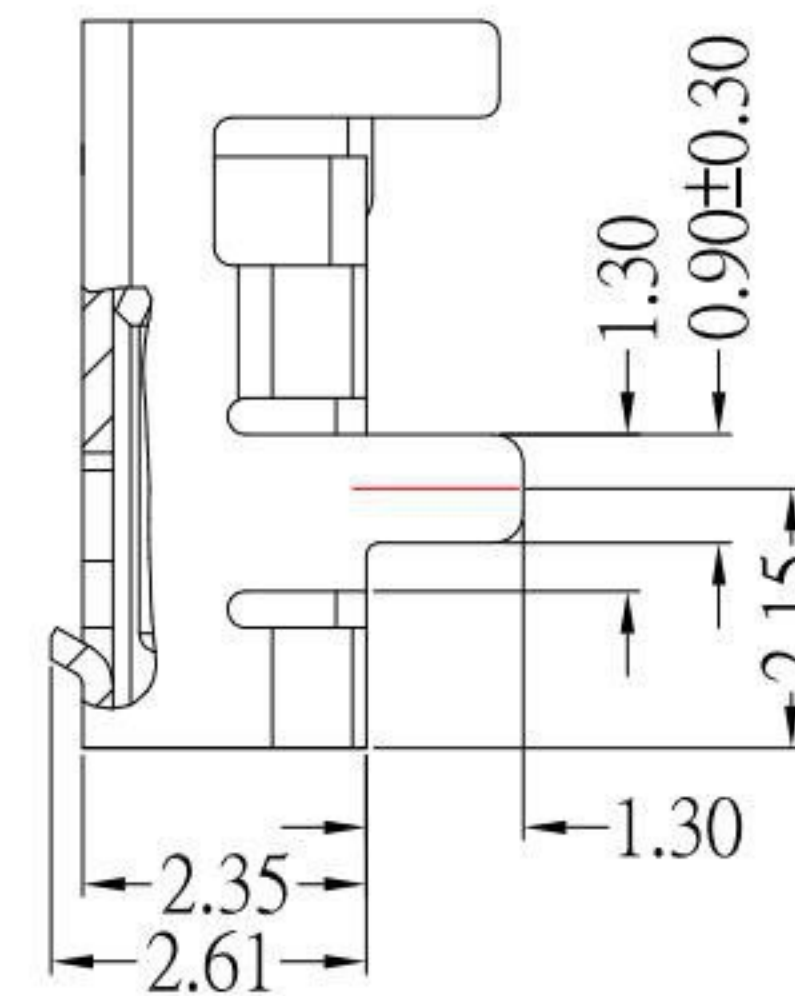
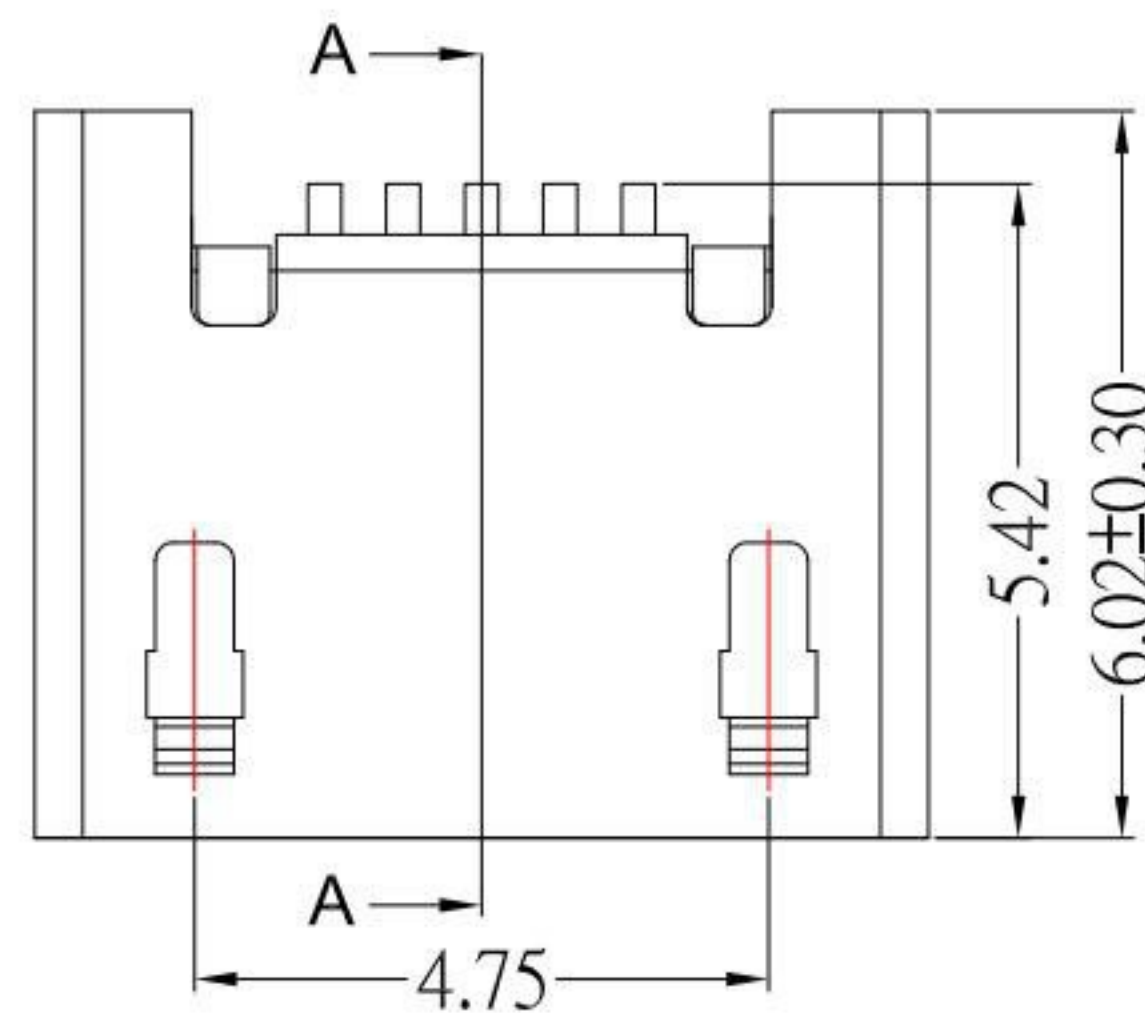

NOTES:

1.MATERIAL:

- 1.1 HOUSING: LCP,UL94V-0
- 1.2 CONTACT: PHOSPHOR BRONZE
- 1.3 SHELL: BRASS / SUS

2.Finish:

- 2.1 Contact: Plated Gold in Mating Area ;
Gold Plated on Solder Balls ;
Nickel under plated overall
- 2.2 SHELL: NICKEL or TIN UNDER PLATED SURFACE LAYER

3.SPECIFICATION:

- 3.1 CURRENT RATING: 1.8 A Max(PIN1,5)
1.0 A Max(PIN2,3,4)
- 3.2 DIELECTRIC WITHSTANDING VOLTAGE: 100 V(ac) FOR 1min
- 3.3 CONTACT RESISTANCE: 30 mΩ MAX.
- 3.4 INSULATION RESISTANCE: 100 MΩ MIN.
- 3.5 TOTAL MATING FORCE: 3.57 Kgf MAX.
- 3.6 TOTAL UNMATING FORCE: 1.0 Kgf MIN.
- 3.7 TEMPERATURE RANGE: -30°C ~ +80°C

KSD 科斯达电子科技有限公司
 SWITCH CONNECTOR KSD ELECTRONIC TECHNOLOGY Co., LTD
 全球 互聯零組件製造企業

TOLERANCE UNLESS OTHERWISE STATED:	Up to 5 ±0.2	3RD. ANGEL'S	UNITS	MM
	Above 5 ~ 15 ±0.3			
	Above 15 ~ 30 ±0.4			
	Above 30 ~ 50 ±0.5			
	Angle ±0.3°			

DRAWN BY:	DATE	MAT'L	TITLE	CONNECTOR
Jack Lu	02/14/20			
CHECKED BY:	DATE	FINISH	MODLE	MICRO USB 5BF 無捲邊 SHELLED DIP TYPE
Jacky Chen	02/14/20			
APPROVED BY:	DATE	SCALE	DWG NO.	MRUSB-5B-D17xx-S347
Tony Kao	02/14/20	1 : 1		
		SHEET NO.	PART NO.	MRUSB-5B-D17xx-S347
		1 of 1		
			SIZE	A4
			VER	R4

4	更新樣式	Jack	021420
3	更新尺寸	Jack	031119
2	更新為A0版	Jack	052217
1	新增材質選項	Jack	051117
ITEM NO.	DESCRIPTION	DRAWN	DATE