

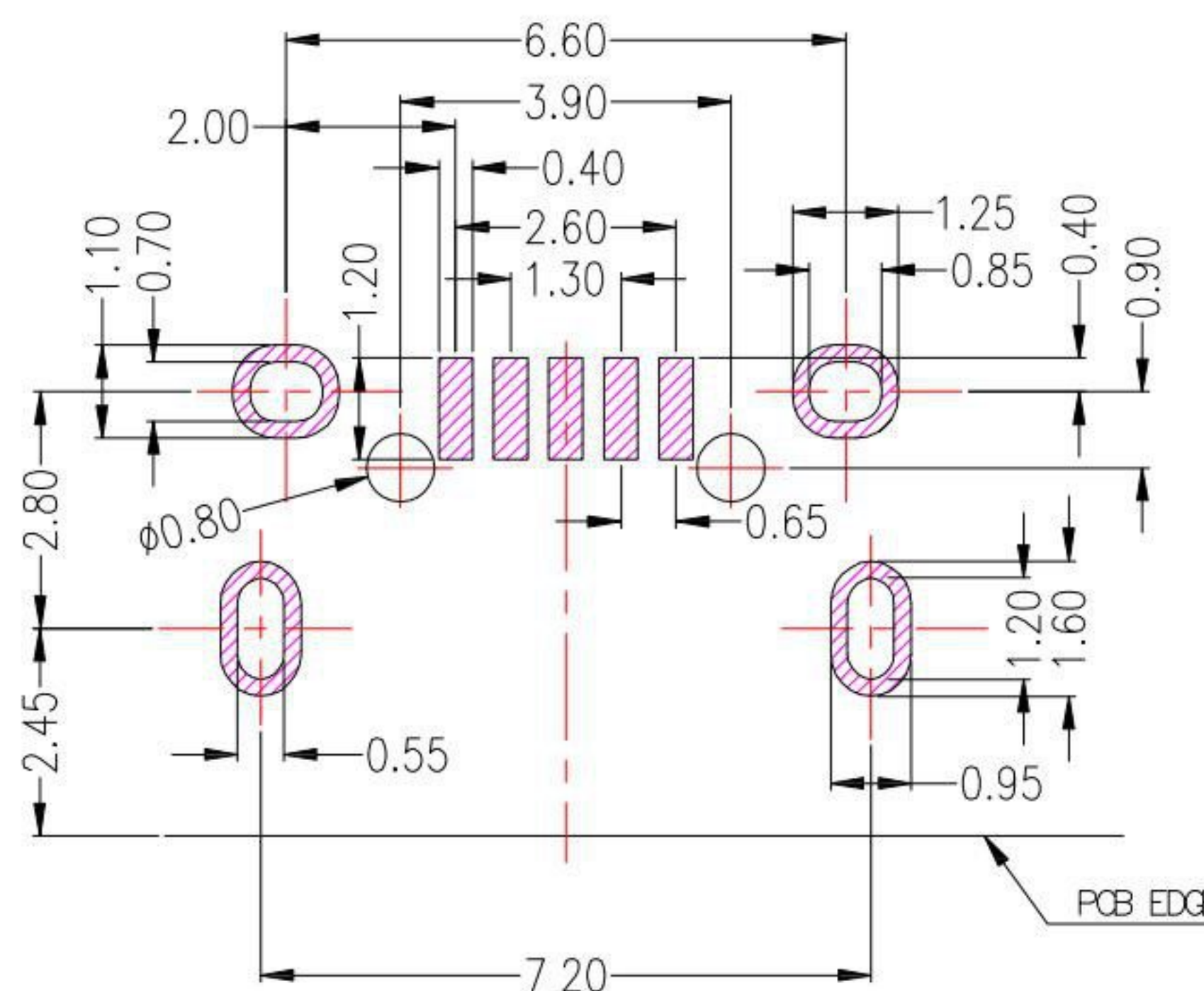

MRUSB-5BED14Bx-S347

SHELL 鍍層:

TN
NI

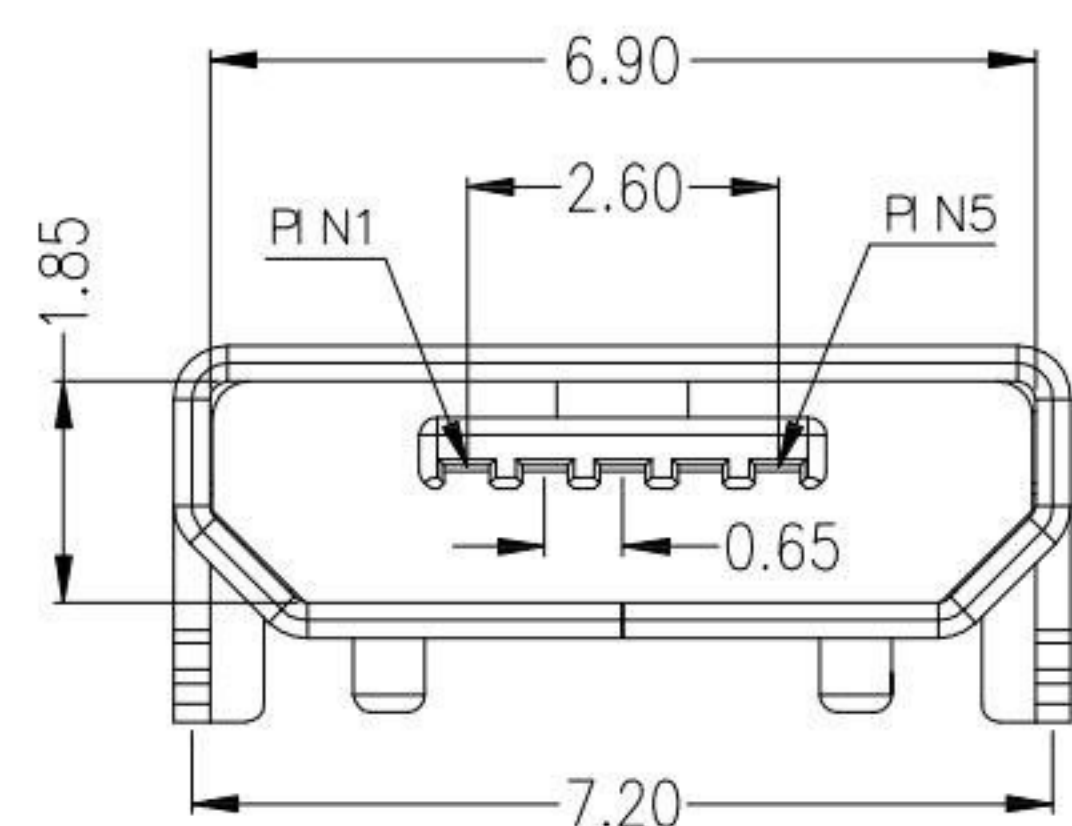
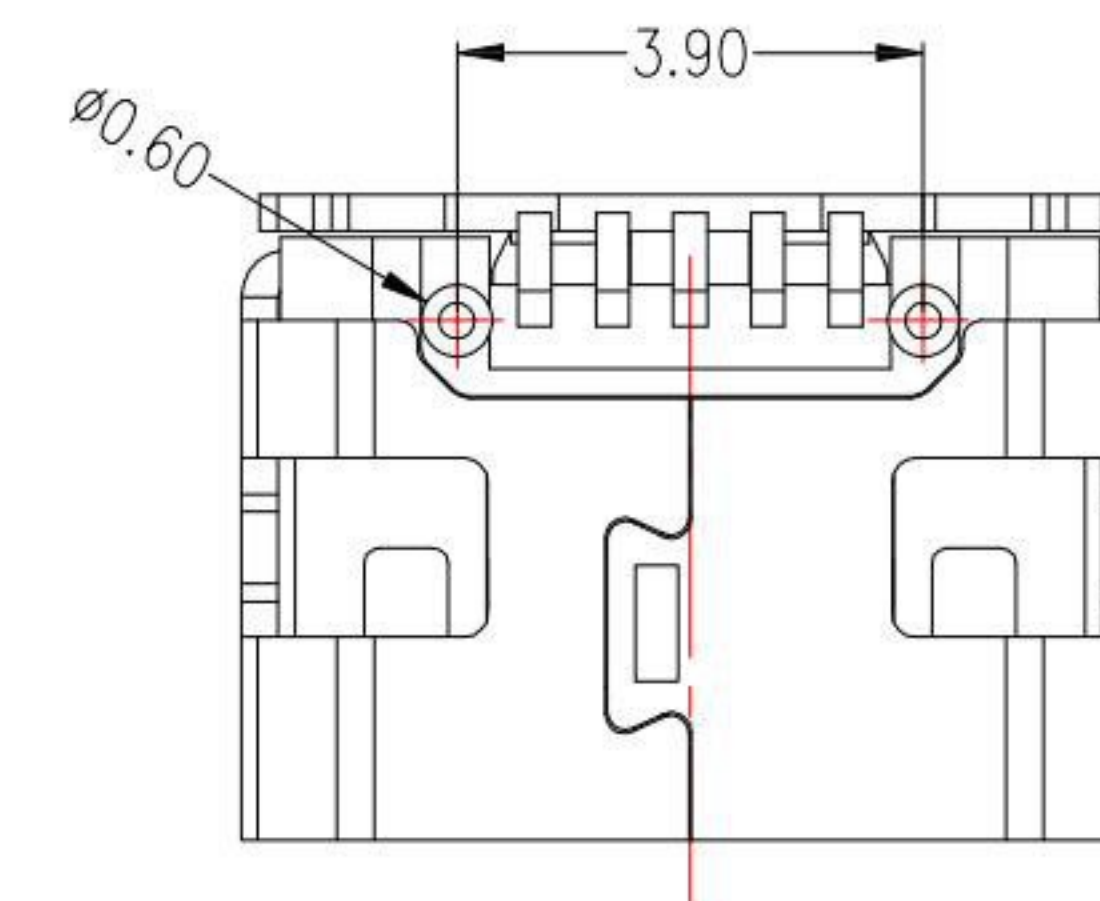
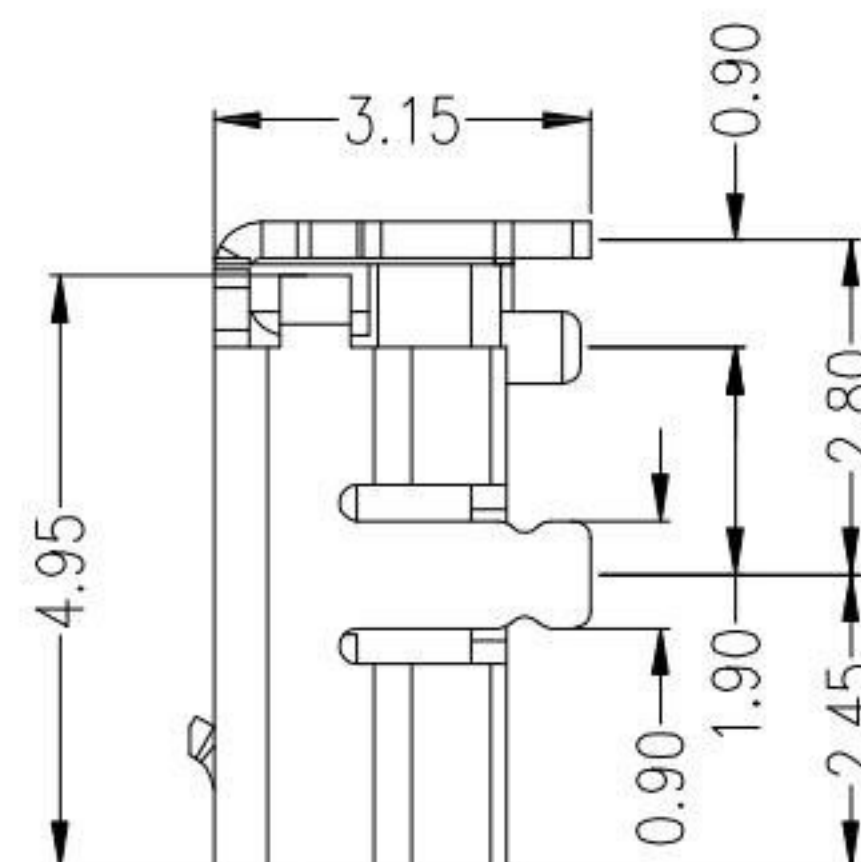
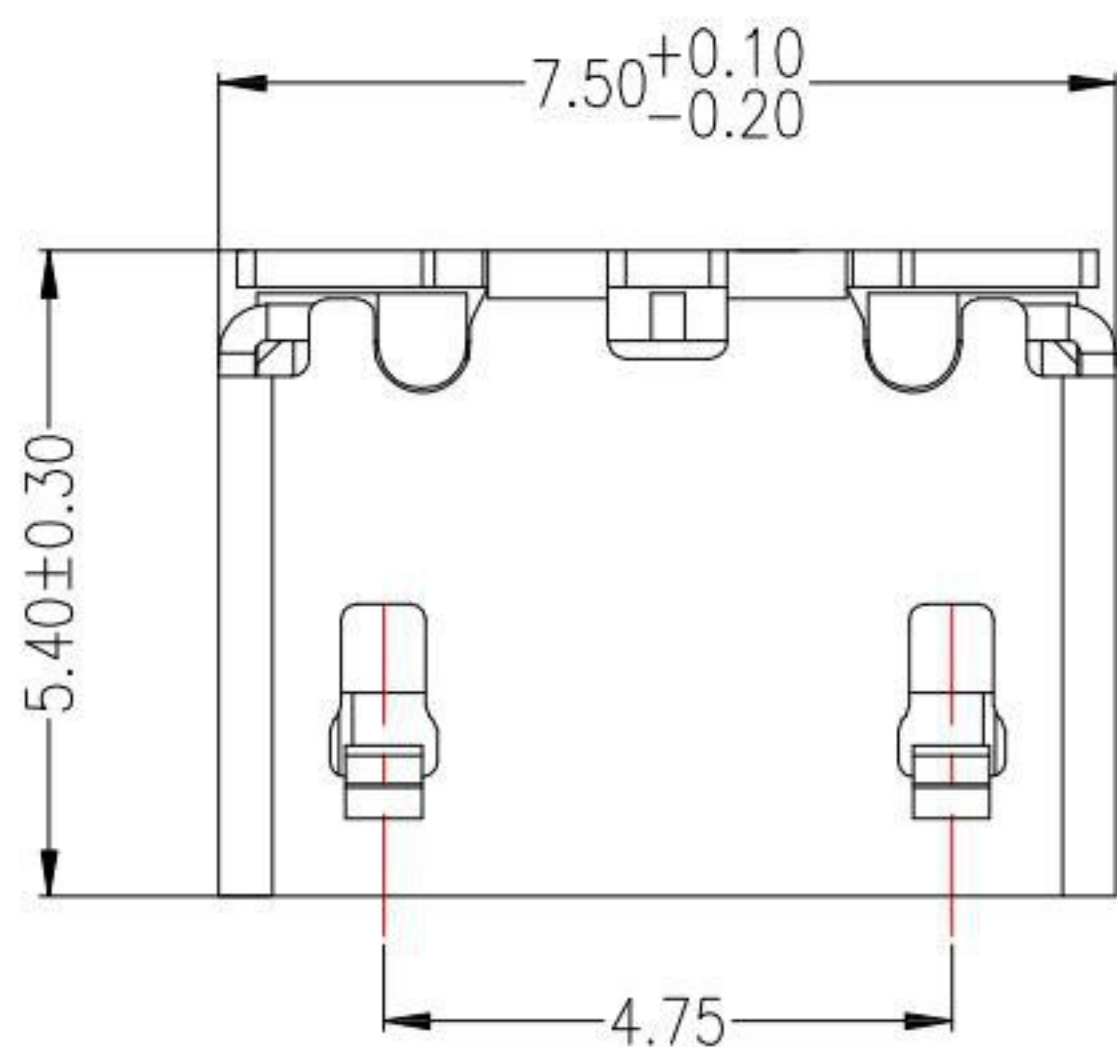
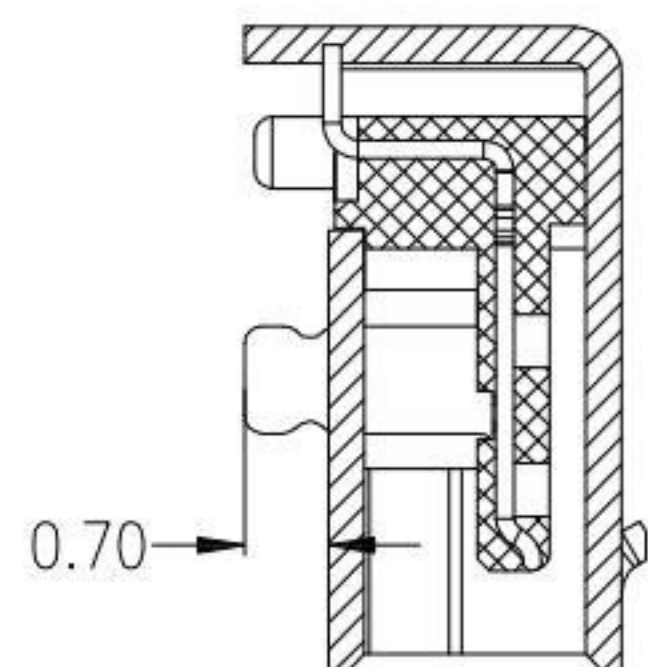
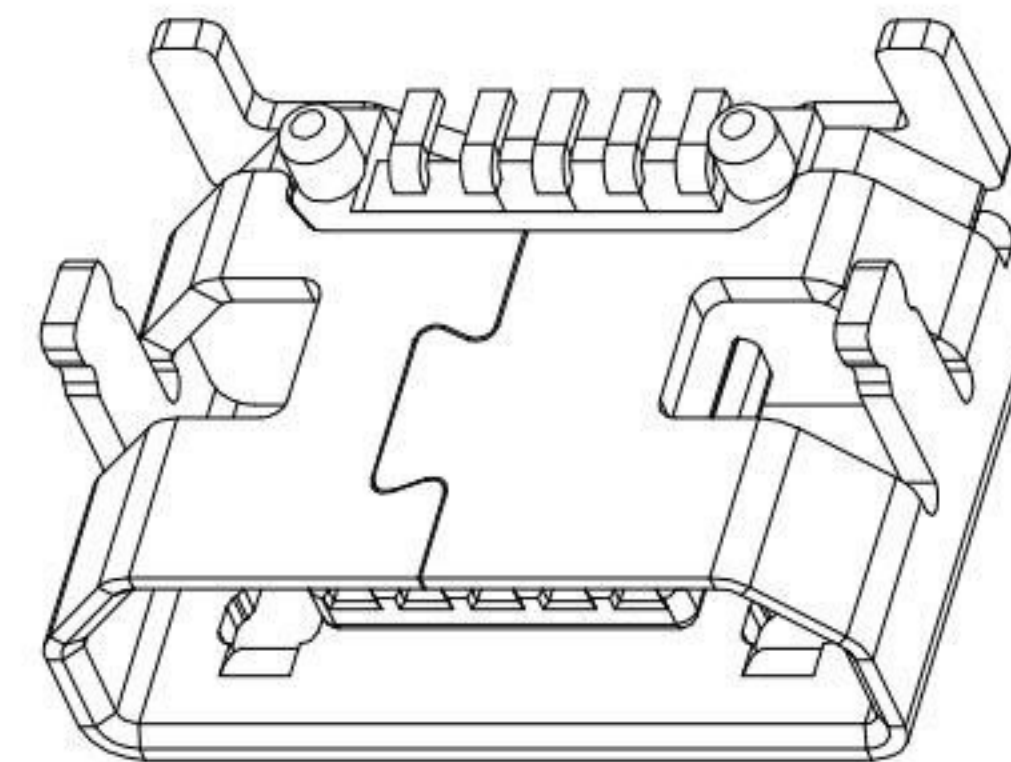
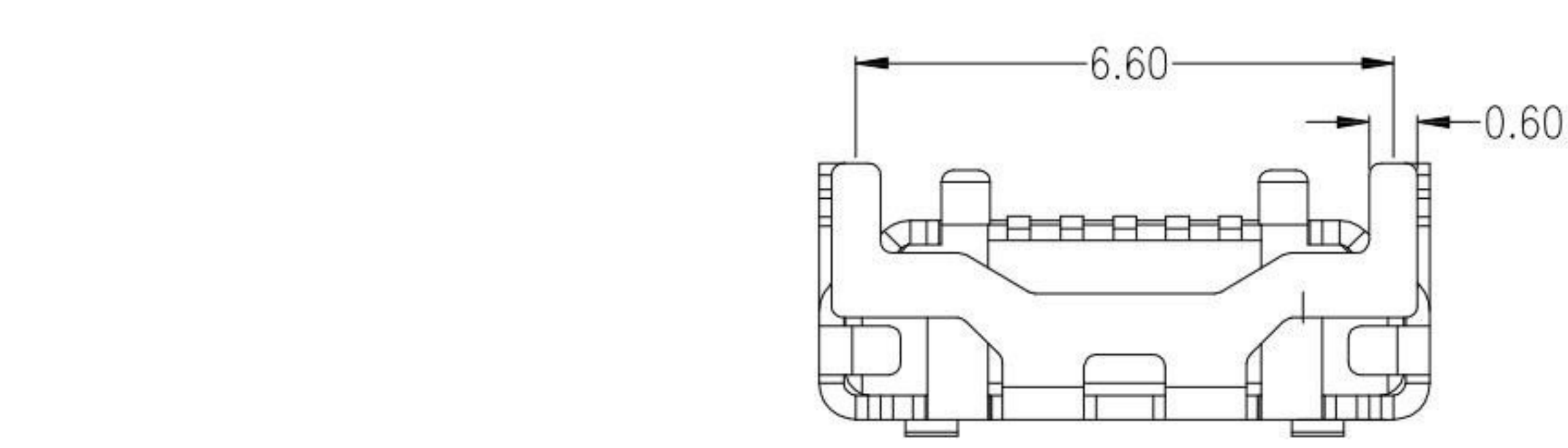

P.C.B LAYOUT MOUNTING PATTERN

NOTES:

1.MATERIAL:

- 1.1 HOUSING: LCP
- 1.2 CONTACT: PHOSPHOR BRONZE
- 1.3 SHELL: SUS

2.Finish:

- 2.1 Contact: Plated Gold in Mating Area ;
Gold Plated on Solder Balls ;
Nickel under plated overall
- 2.2 Shell: Tin or Nickel under Plated surface layer

3.SPECIFICATION:

- 3.1 CURRENT RATING: 1.8 A (PIN1,5) ; 1.0 A (PIN2,3,4)
- 3.2 DIELECTRIC WITHSSTANDING VOLTAGE: 100 V(ac) FOR 1min
- 3.3 CONTACT RESISTANCE: 30 mΩ MAX.
- 3.4 INSULATION RESISTANCE: 100 MΩ MIN.
- 3.5 TOTAL MATING FORCE: 3.57 Kgf MAX.
- 3.6 TOTAL UNMATING FORCE: 1.0 Kgf MIN.
- 3.7 TEMPERATURE RANGE: -30°C ~ +80°C

KSD 科斯达电子科技有限公司
 SWITCH CONNECTOR KSD ELECTRONIC TECHNOLOGY Co., LTD
 全球 互聯零組件 制造企业

TOLERANCE UNLESS OTHERWISE STATED:	Up to 5 ±0.2	3RD. ANGEL'S	UNITS	MM
	Above 5 ~ 15 ±0.3			
	Above 15 ~ 30 ±0.4			
	Above 30 ~ 50 ±0.5			
	Angle ±0.3°			

DRAWN BY:	DATE	MAT'L	TITLE	CONNECTOR
Jack Lu	08/02/18		MODLE	MICRO USB 5BF 牛角(PH7.2-6.6) 有柱,無捲邊
CHECKED BY:	DATE	FINISH	DWG NO.	MRUSB5B-ED14Bx-S347
Jacky Chen	08/02/18		PART NO.	MRUSB5B-ED14Bx-S347
APPROVED BY:	DATE	SCALE	SHEET NO.	1 of 1
Tony Kao	08/02/18	1 : 1		

ITEM NO.	DESCRIPTION	DRAWN	DATE