

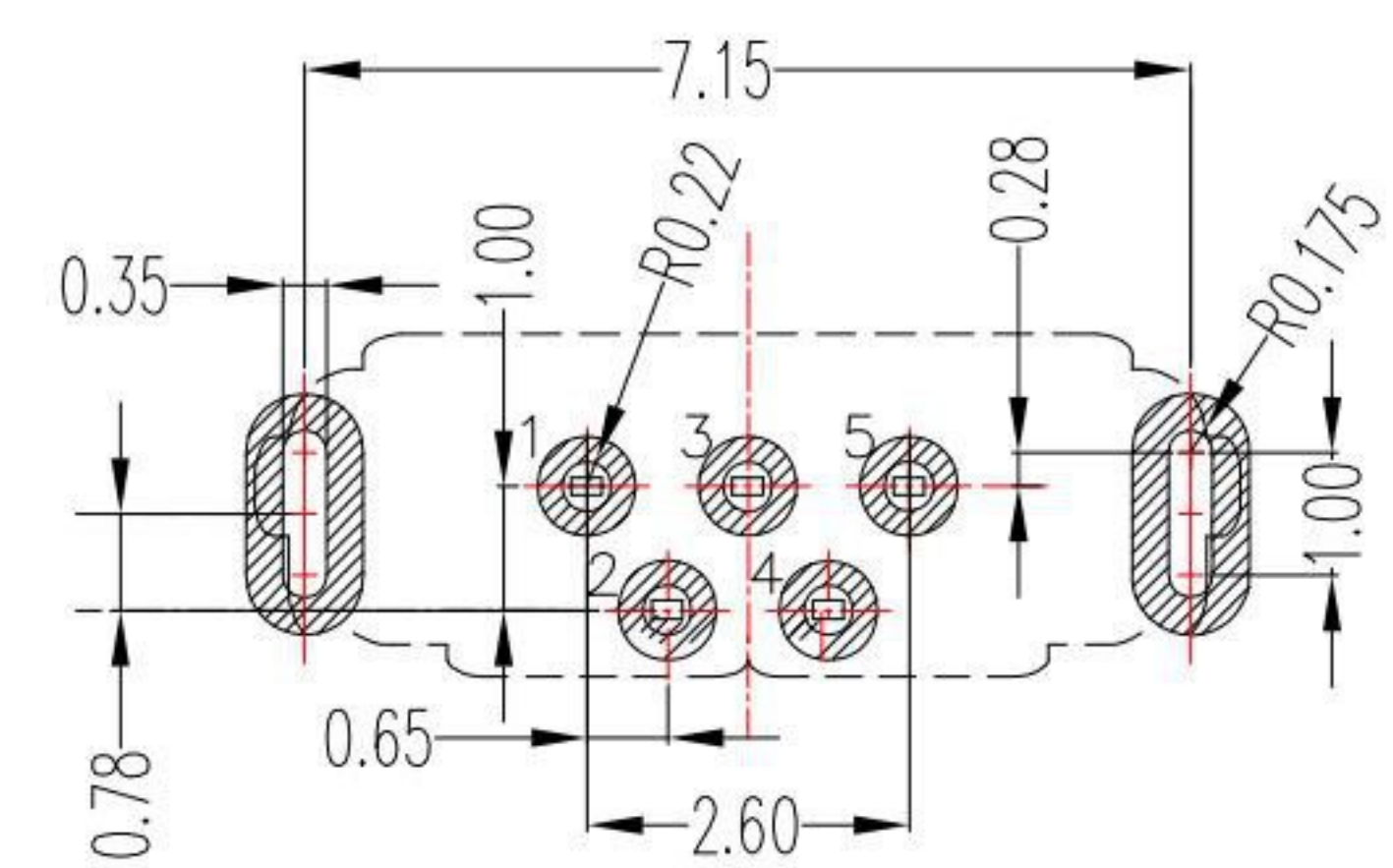

# MRUSB-5B-V-x-S129

鍍層厚度:

Blank	: 1u"
2	: 15u"
3	: 30u"

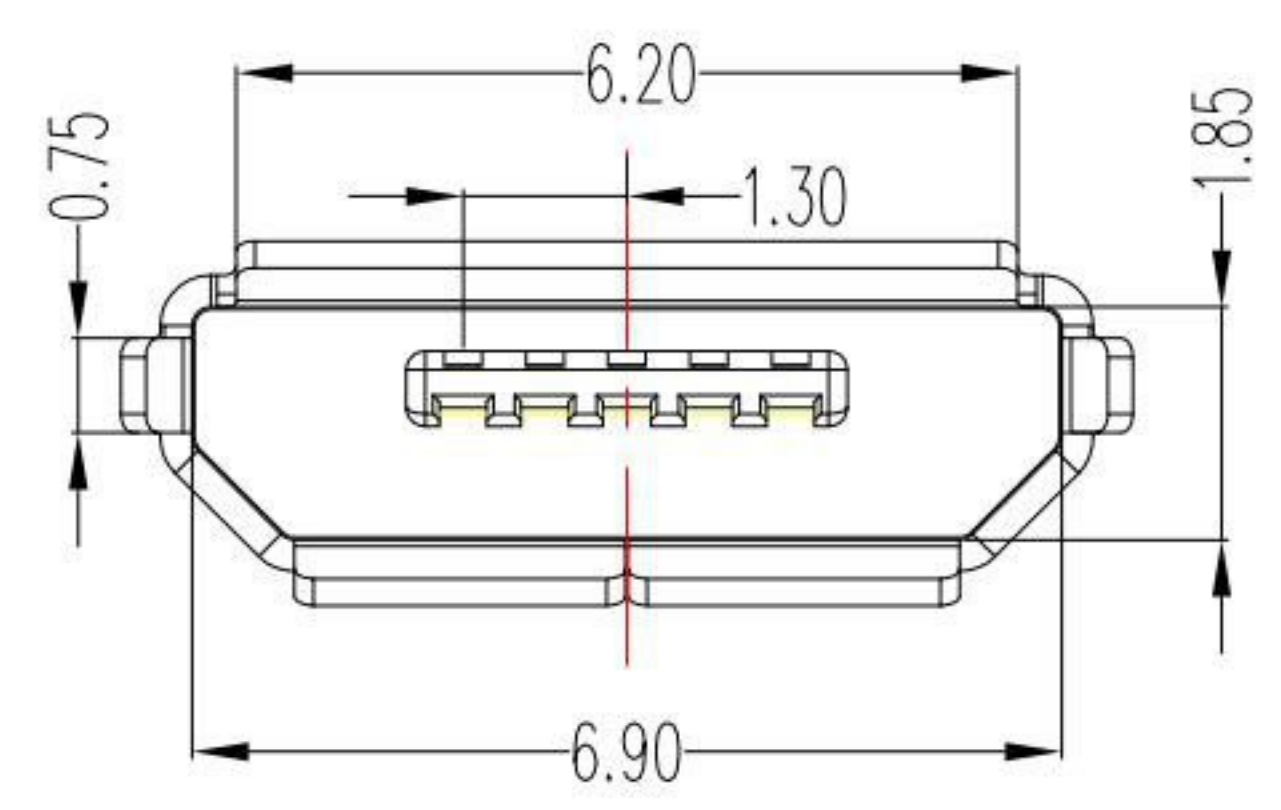
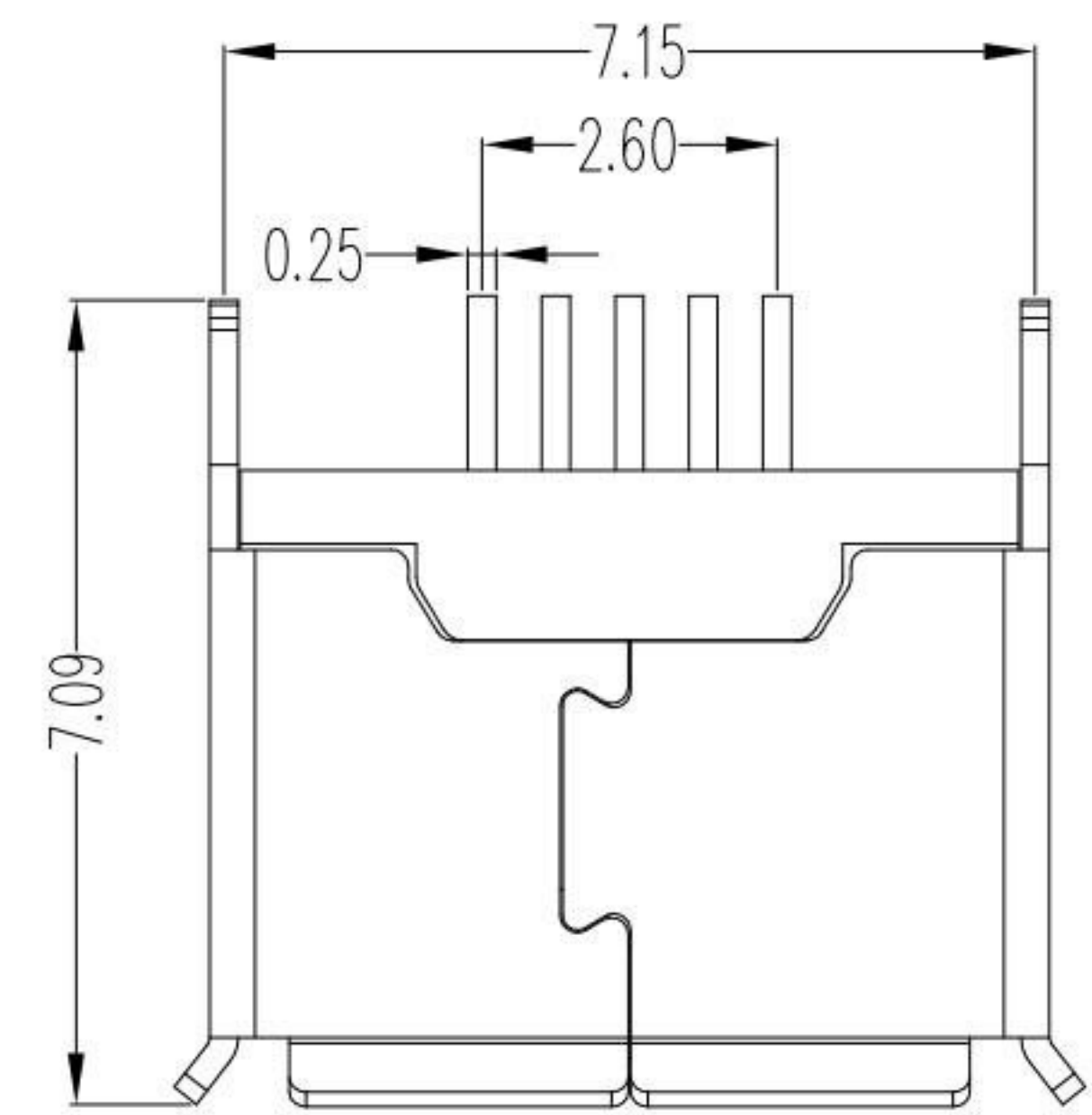
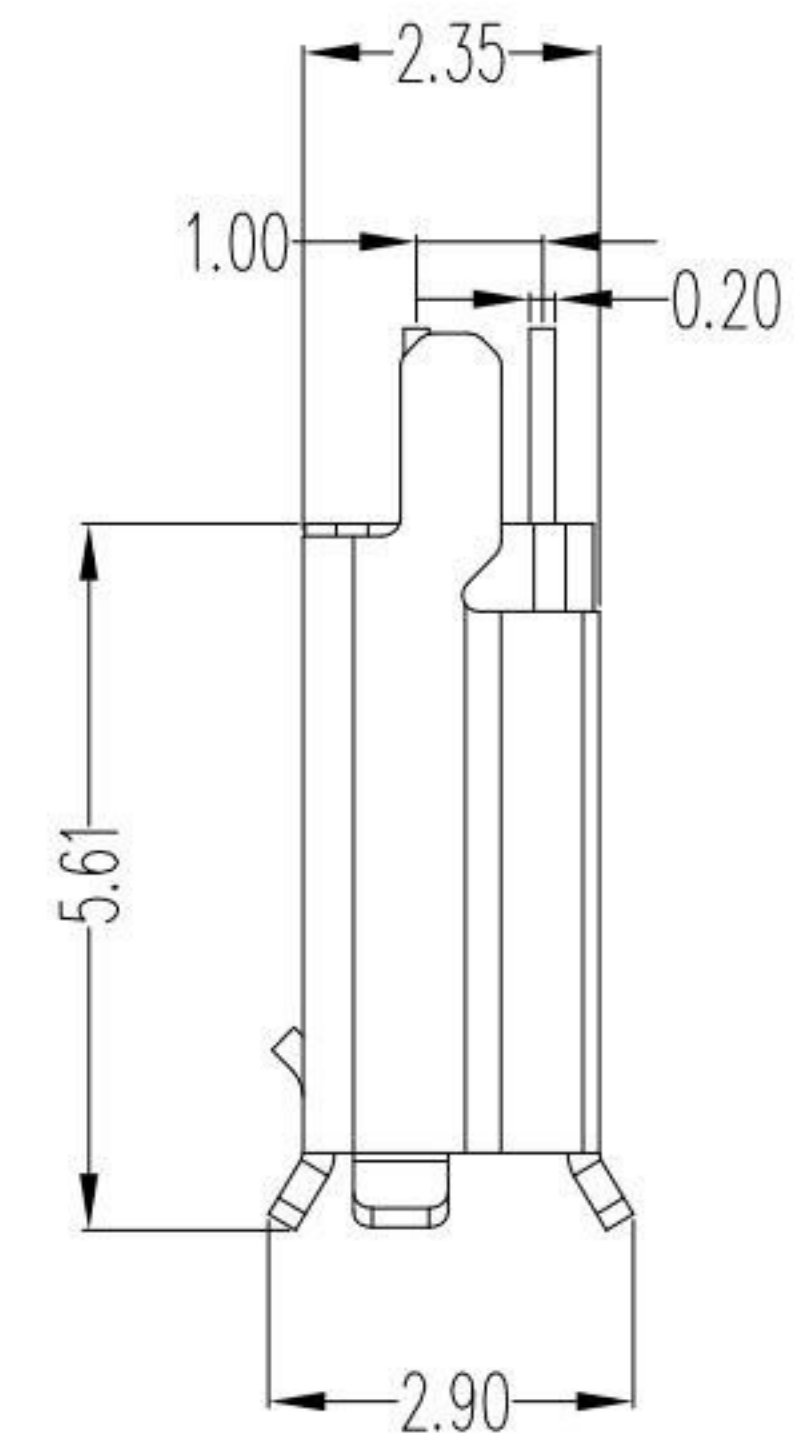
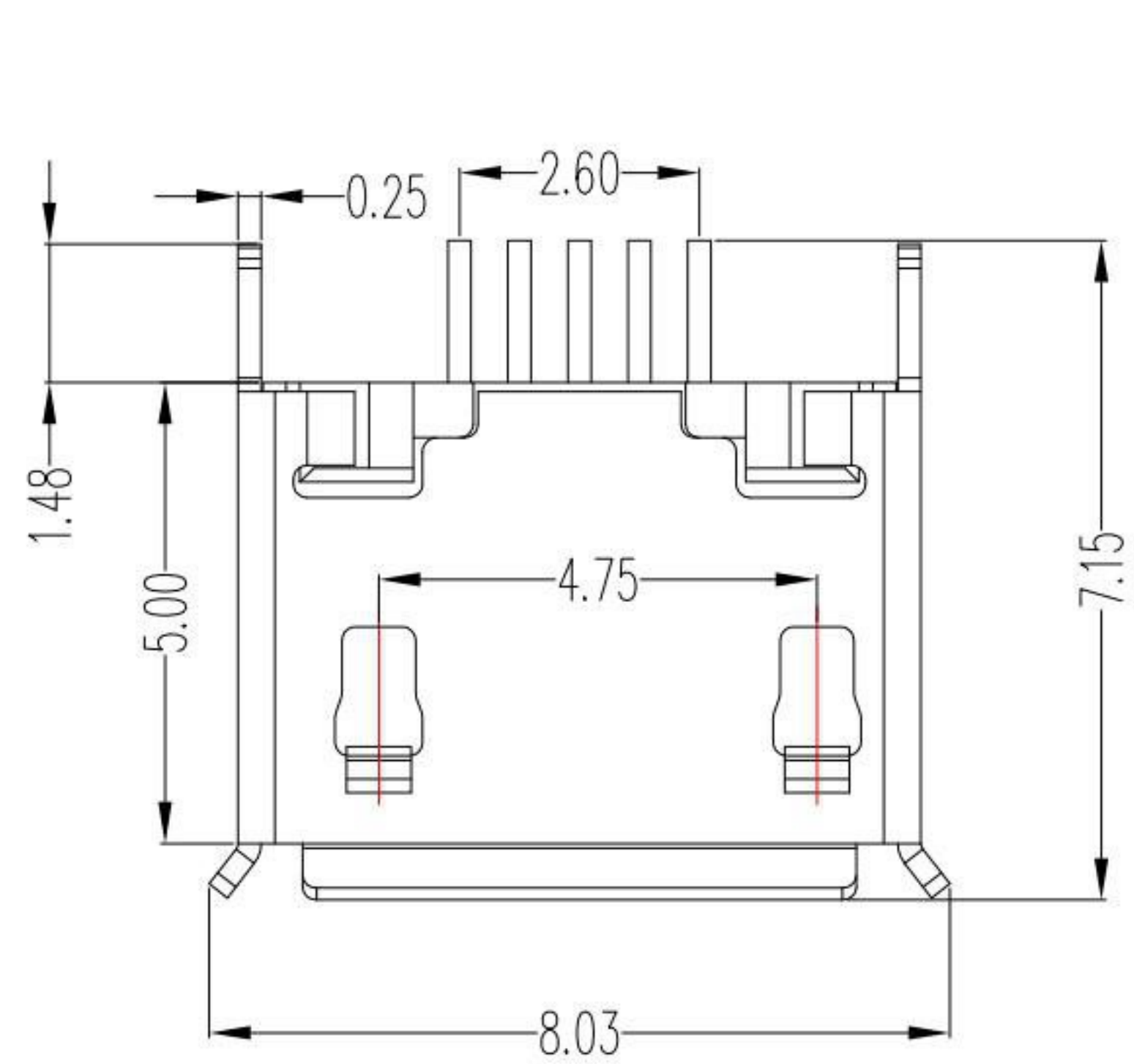

P.C.B LAYOUT MOUNTING PATTERN

## SPECIFICATIONS

- Electrical:
  - Current Rating: 1.5Ampere Maximum for Pin1&Pin5  
0.5Ampere Maximum for Pin2&Pin3&Pin4
  - Voltage Rating: 30V
  - Contact resistance : 30mΩ max.
  - Dielectric withstanding voltage : 100 V AC.
  - Insulation resistance : 100MΩ min.
- Mechanical:
  - Mate and unmate force:
  - Mate force : 35N MAX
  - Unmate force : 10N MIN
- Environment:
  - Operating Temperature : -30°C to +80°C.
- Material:
  - Housing : LCP,UL94V-0
  - Contact: Phosphor Bronze
  - Shell: SUS
- Plating Layer:
  - Contact: Plated Gold in Mating Area ;  
Gold Plated on Solder Balls ;  
Nickel under plated overall
  - Shell: Tin under Plated surface layer

6	新增2.35尺寸	Jack	063015
5	更新PCB LAYOUT尺寸	Jack	050615
4	更新材質	Jack	092214
3	更新尺寸	Jack	053014
2	更新為A0版	Jack	040814
1	更新材質及外殼電鍍	Jack	121813
ITEM NO.	DESCRIPTION	DRAWN	DATE

**KSD** 科斯达电子科技有限公司  
 SWITCH CONNECTOR KSD ELECTRONIC TECHNOLOGY Co., LTD  
 全球 互聯零組件製造企業

TOLERANCE UNLESS OTHERWISE STATED:

Up to 5	±0.2
Above 5 ~ 15	±0.3
Above 15 ~ 30	±0.4
Above 30 ~ 50	±0.5
Angle	±0.3°

3RD. ANGEL'S UNITS MM

DRAWN BY:	DATE	MAT'L	TITLE	CONNECTOR
Jack Lu	06/30/15			
CHECKED BY:	DATE	FINISH	MODLE	MICRO USB B TYPE 180 度 DIP 腳
Jacky Chen	06/30/15			
APPROVED BY:	DATE	SCALE	DWG NO.	MRUSB-5B-V-x-S129
Tony Kao	06/30/15	1 : 1		
SHEET NO.	1 of 1	PART NO.	MRUSB-5B-V-x-S129	SIZE A4
				VER A4