

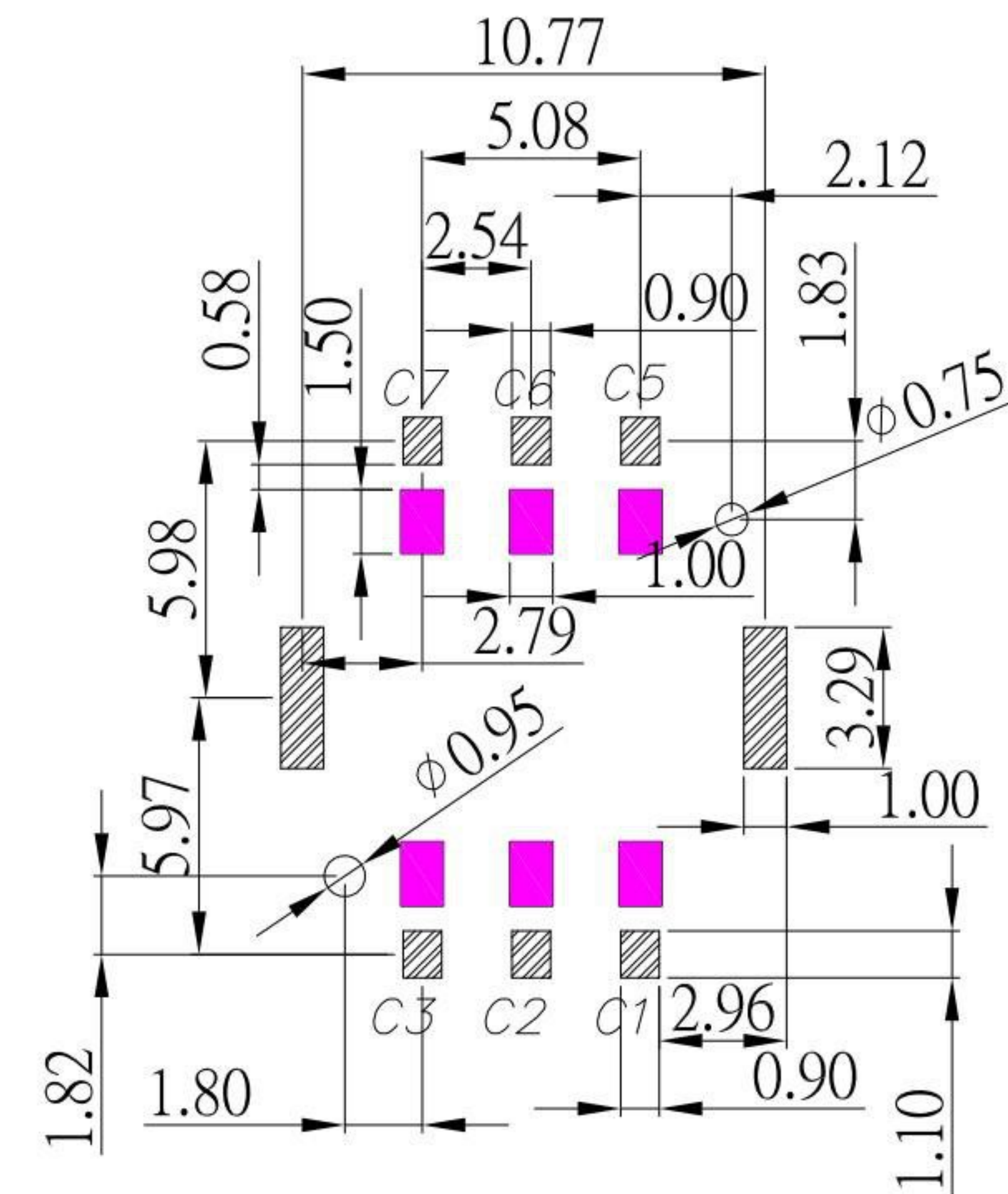

SIM pin assignment	
PIN#	Name
C1	VCC
C2	RST
C3	CLK
C5	GND
C6	VPP
C7	I/O

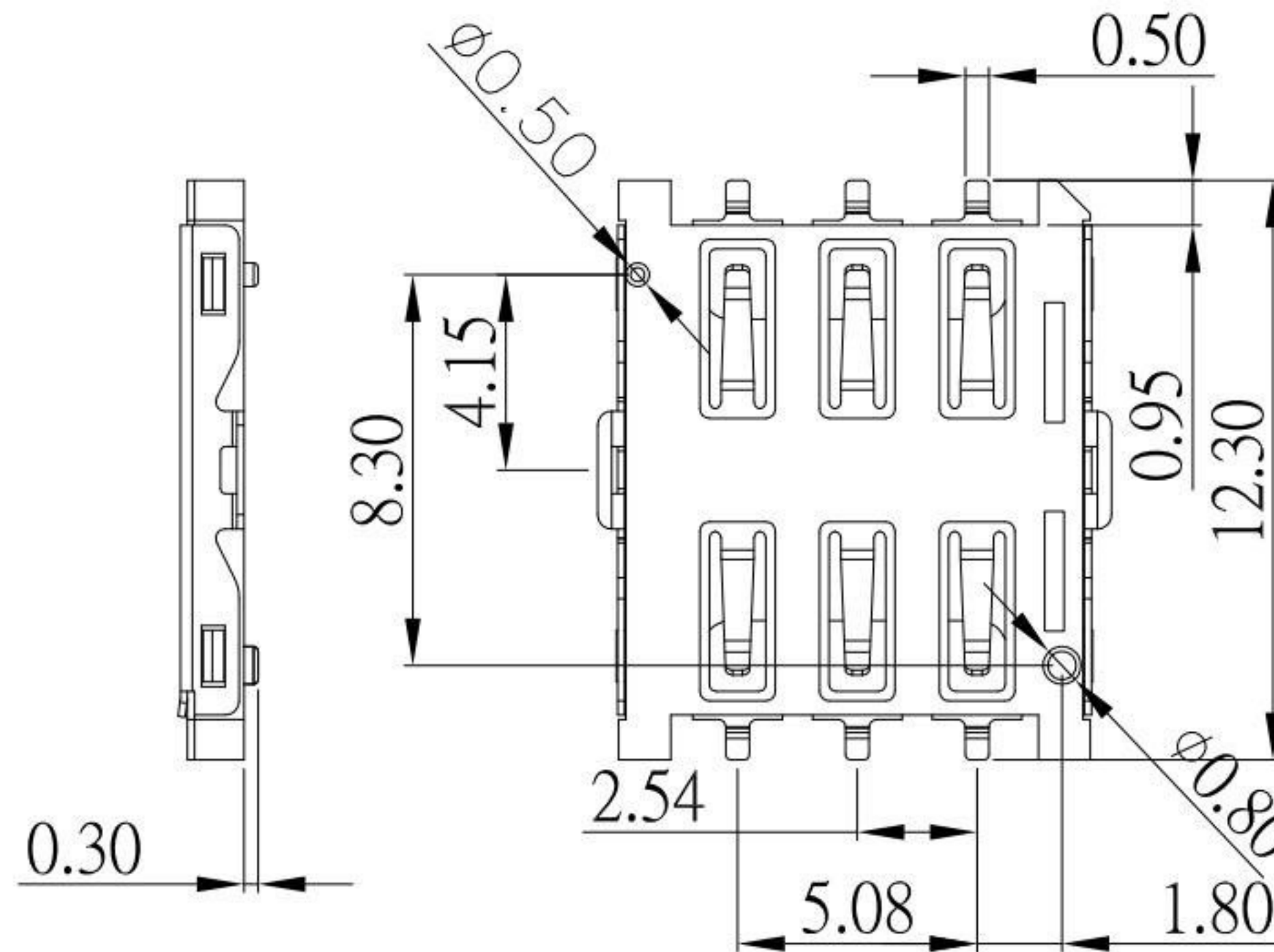
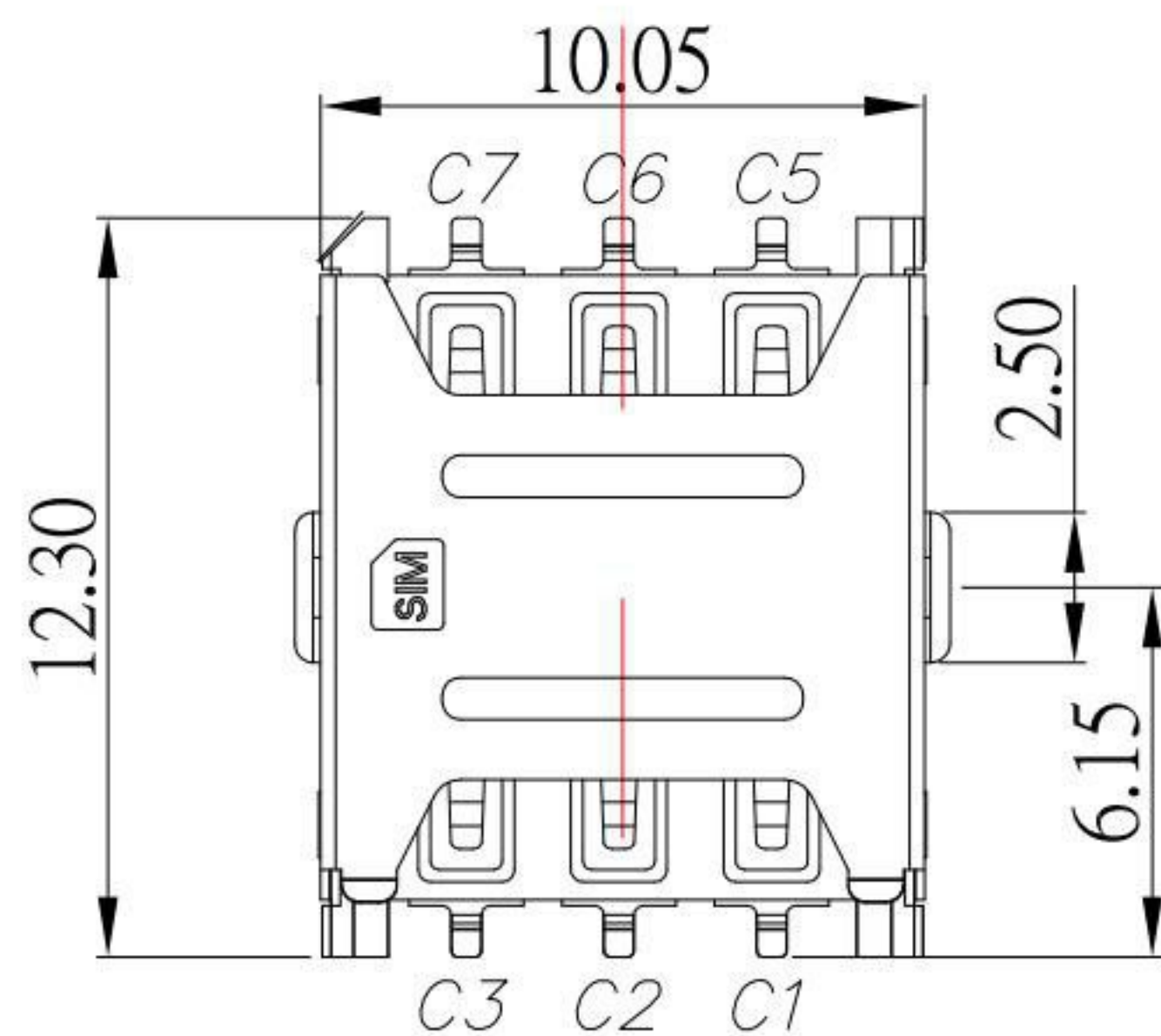
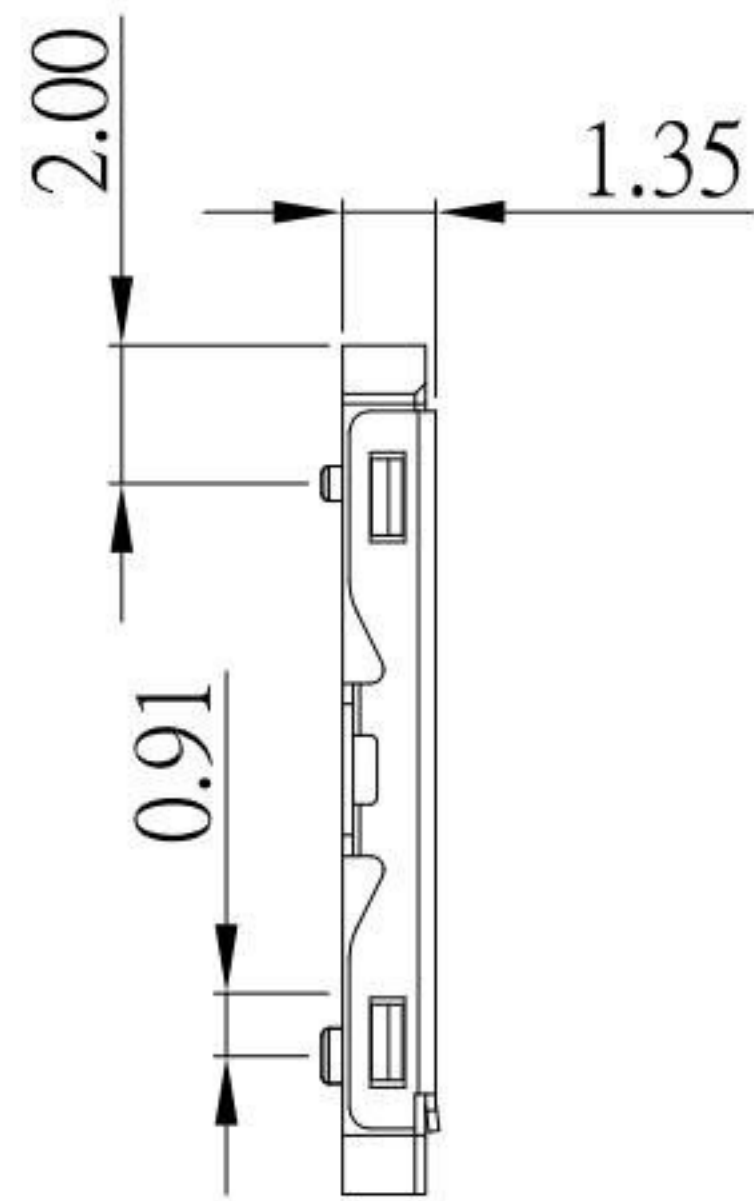
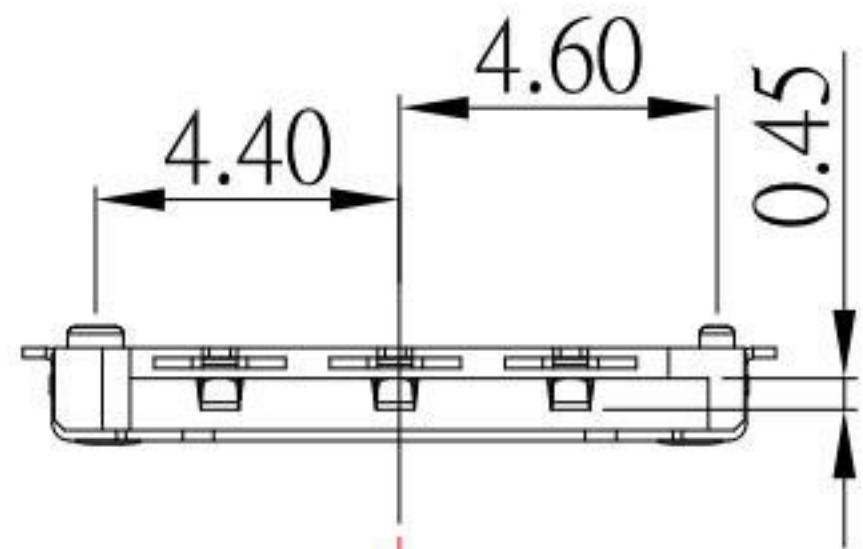

PCB 通空位置
 RECOMMENDED PCB LAYOUT

P.C.B LAYOUT MOUNTING PATTERN

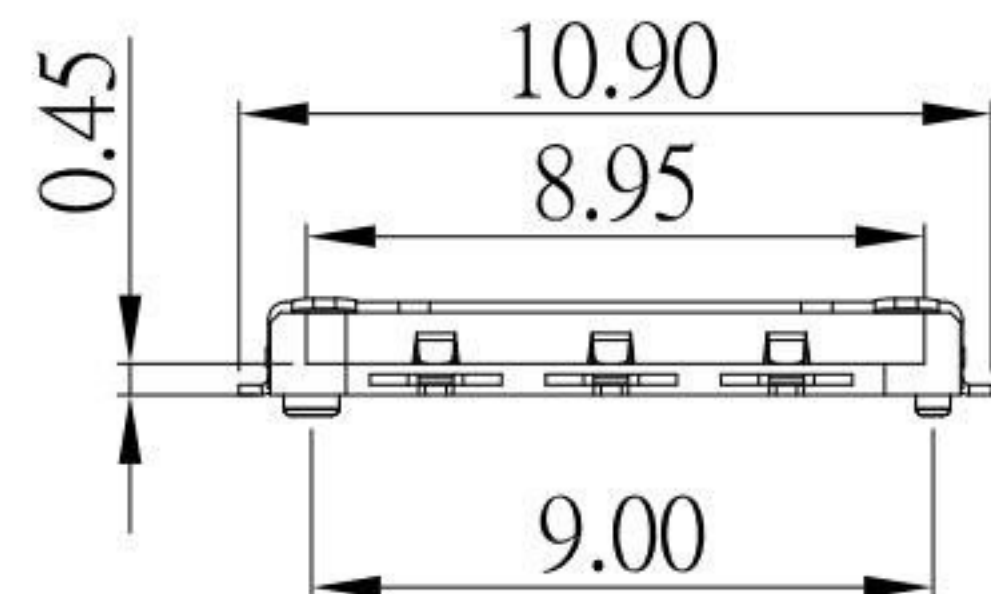
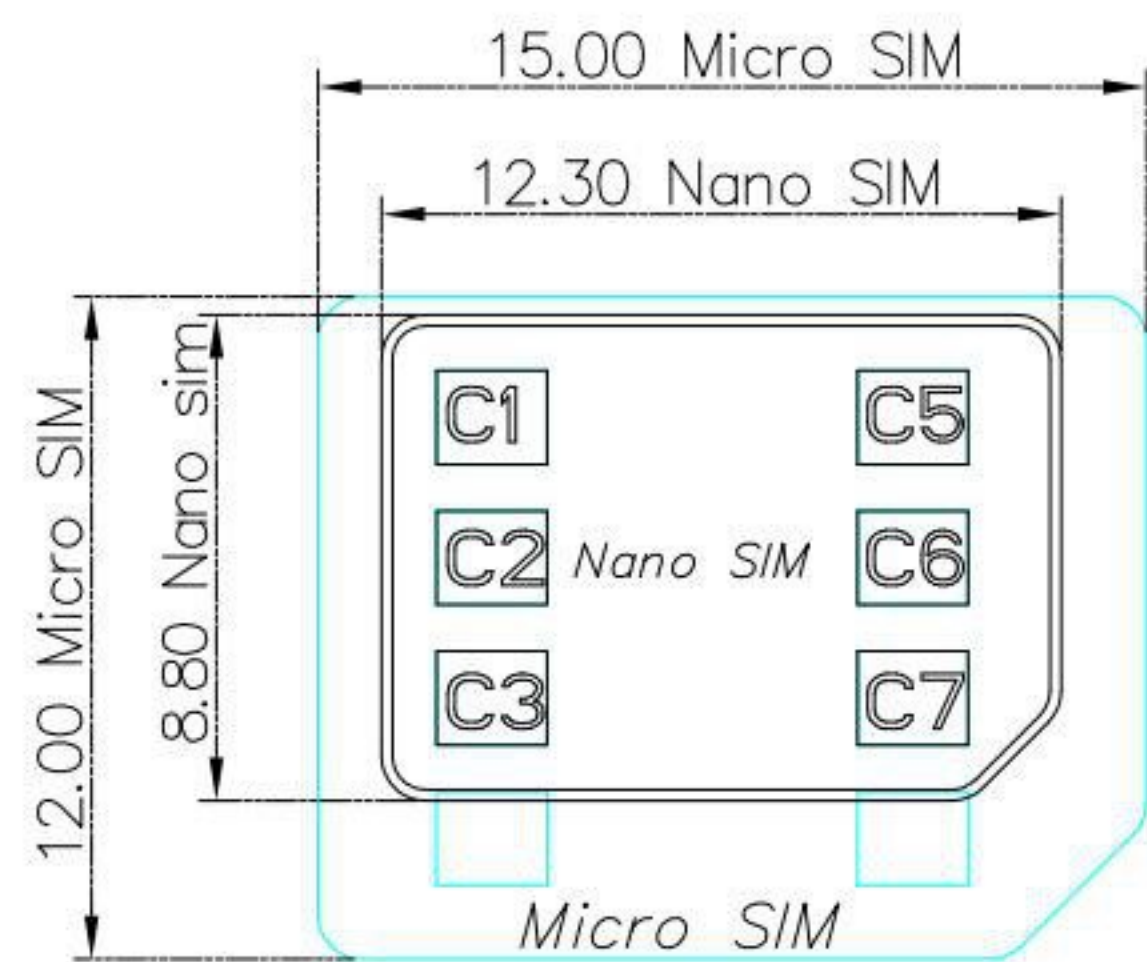

MATERIALS:

1. HOUSING : HIGH TEMPERATURE THERMOPLASTIC
2. CONTACT : PHOSPHOR BRONZE
3. SHELL : SUS

Finish:

1. Finish: CONTACT: PLATED GOLD IN MATING AREA ;
GOLD PLATED ON SOLDER BALLS ;
NICKEL UNDER PLATED OVERALL
2. SHELL: NICKEL UNDER PLATED SURFACE LAYER

SPECIFICATION:

1. CURRENT RATING : 0.5 mA AC / DC MAX.
2. VOLTAGE RATING : 125V AC / DC
3. INSULATION RESISTANCE : 1000MΩ MIN.
4. CONTACT RESISTANCE : 100mΩ MAX.
5. OPERATING TEMPERATURE RANGE : -40°C TO +85°C.
6. STORAGE TEMPERATURE RANGE : -40°C TO +85°C.

KSD 科斯达电子科技有限公司
 SWITCH CONNECTOR KSD ELECTRONIC TECHNOLOGY Co., LTD
 全球 互聯零組件 制造企业

TOLERANCE UNLESS OTHERWISE STATED :
 Up to 5 ±0.2
 Above 5 ~ 15 ±0.3
 Above 15 ~ 30 ±0.4
 Above 30 ~ 50 ±0.5
 Angle ±0.3

3RD. ANGEL'S

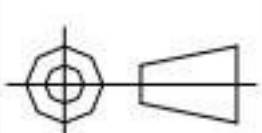

UNITS MM

DRAWN BY:	DATE	MAT'L	TITLE	CONNECTOR
Jack Lu	02/01/23			
CHECKED BY:	DATE	FINISH	MODLE	Nano SIM CARD NO PUSH 1.35H 有柱
Jacky Chen	02/01/23			
APPROVED BY:	DATE	SCALE	DWG NO.	NSIM-0201G06A-S267
Tony Kao	02/01/23	1 : 1		
SHEET NO.	1 of 1	PART NO.	NSIM-0201G06A-S267	

ITEM NO.	DESCRIPTION	DRAWN	DATE
2	修正尺寸標示	Jack	020123
1	更新OPERATING TEMPERATURE RANGE	Jack	101221