

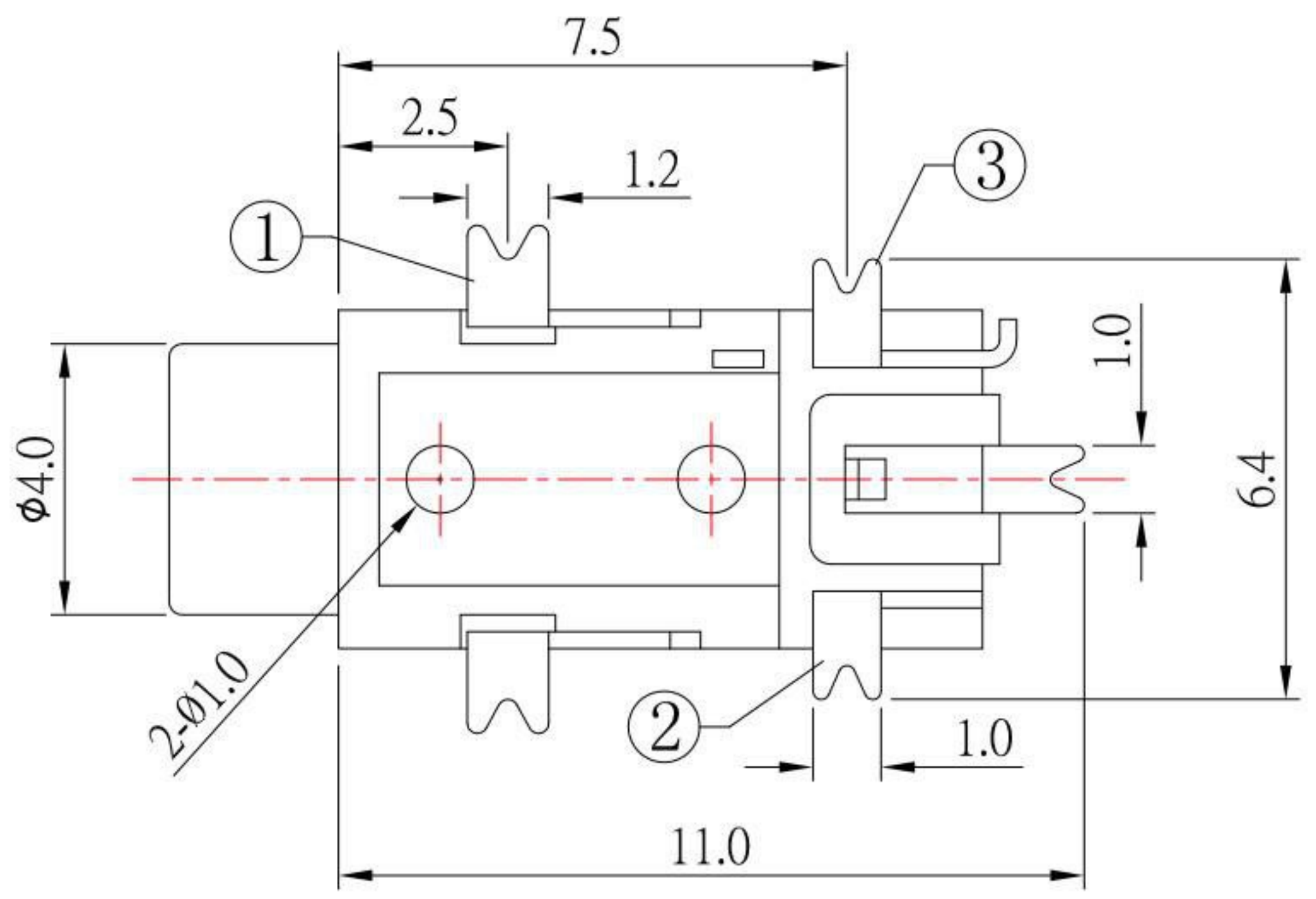

P.C.B LAYOUT MOUNTING PATTERN
(TOP VIEW)

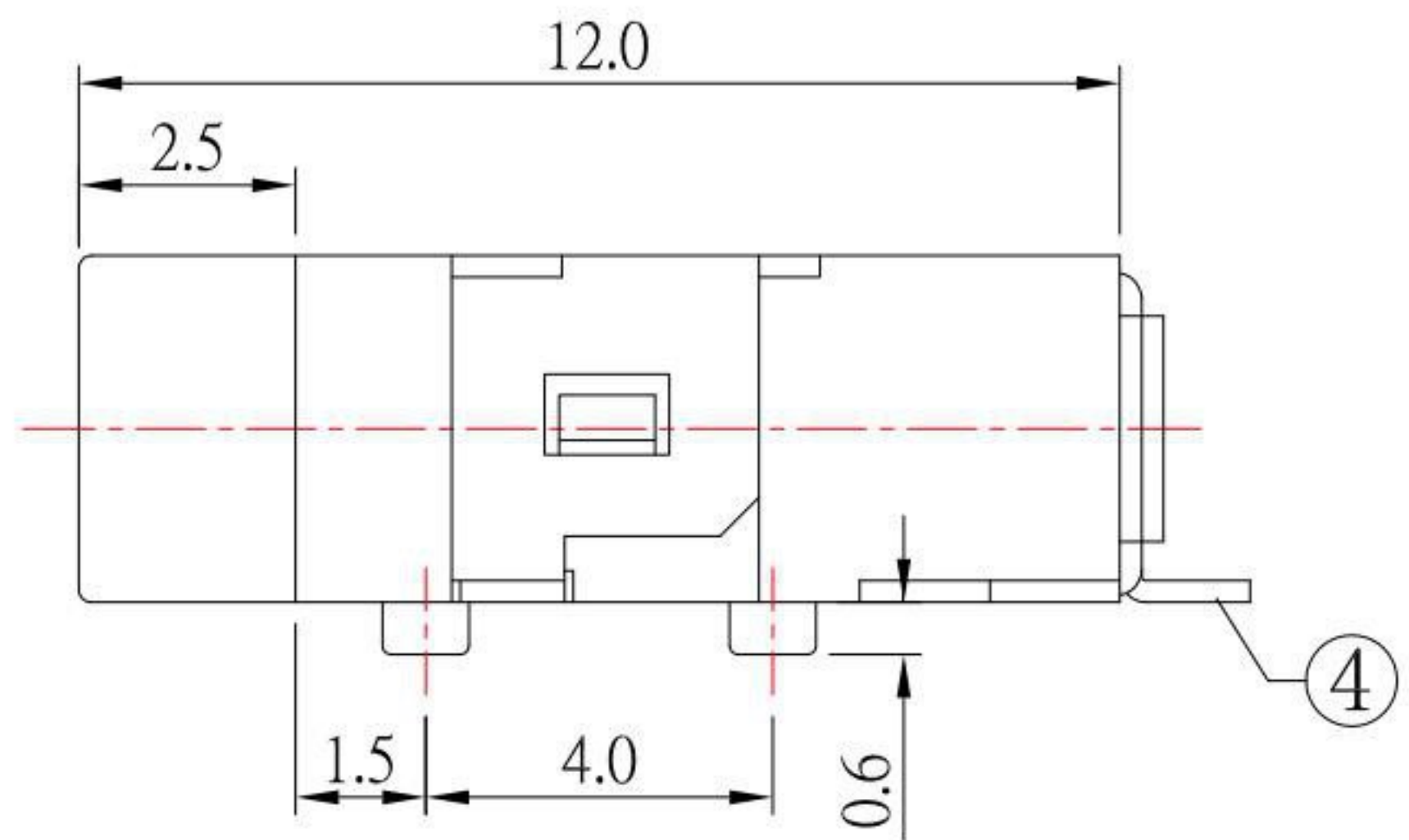
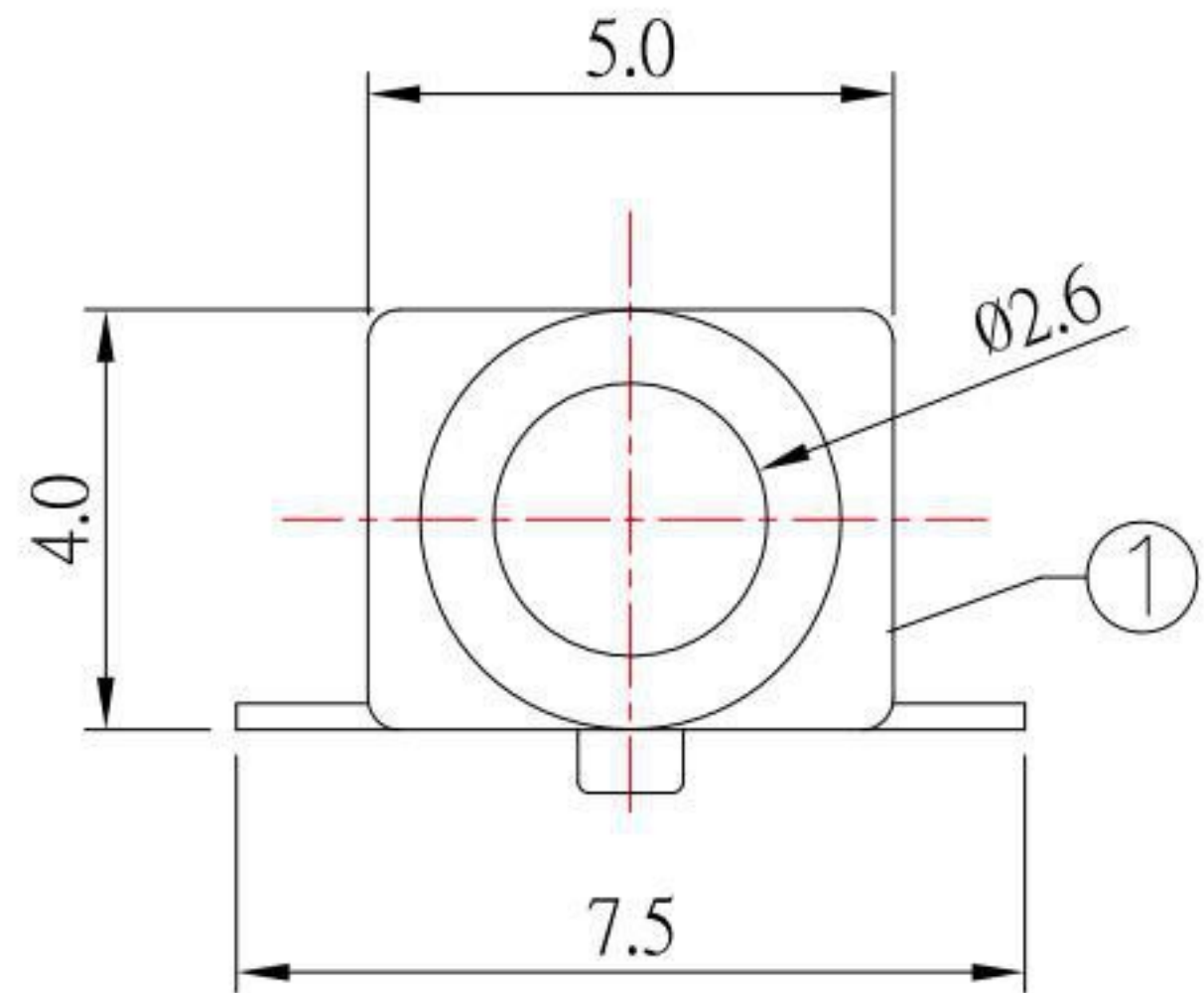
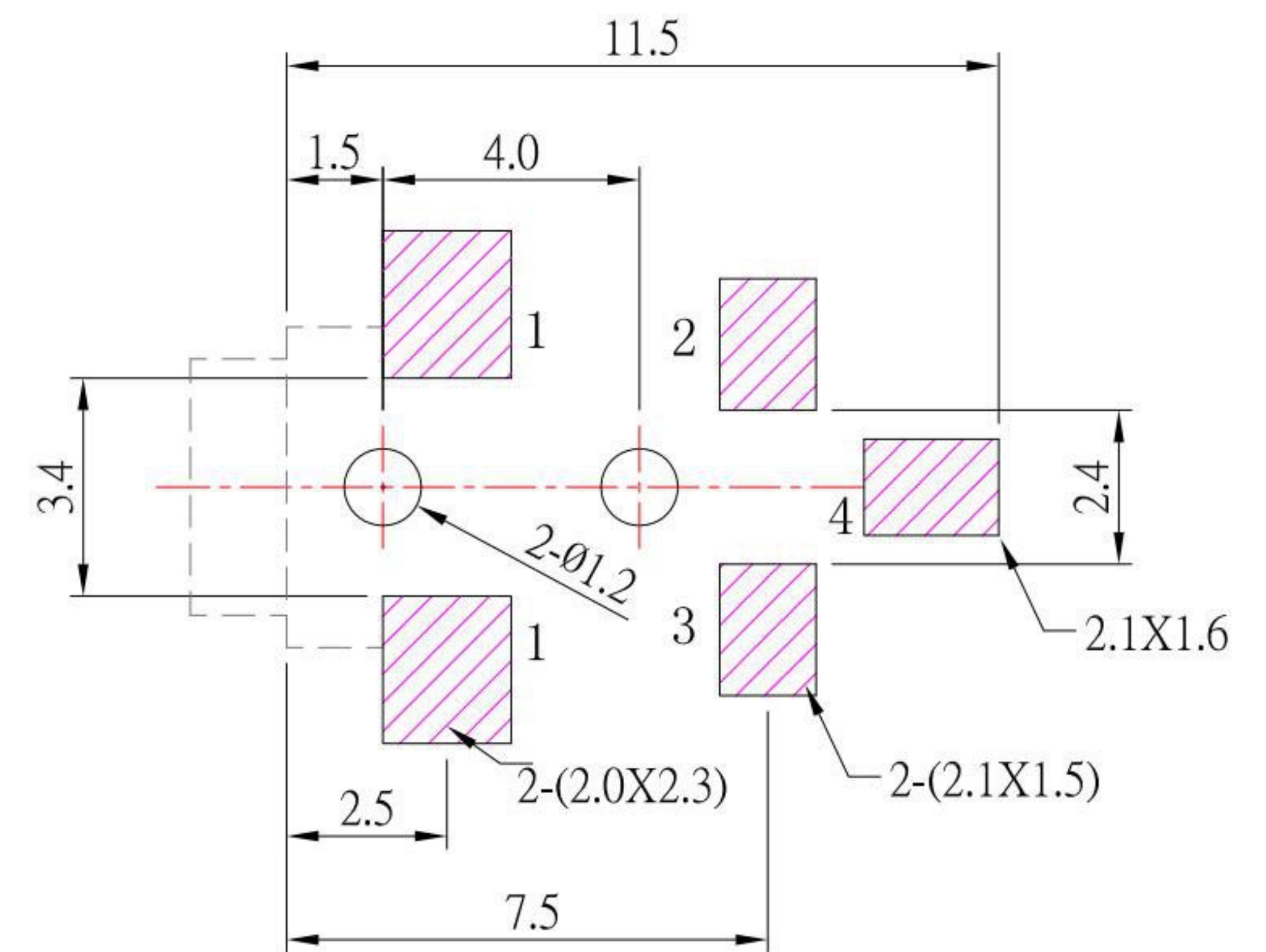

SPECIFICATION

1. Rating : DC 30V 0.5A ;
2. Contact resistance : $\leq 30m\Omega$;
3. Insulation resistance : $\geq 100M\Omega$ (DC250V) ;
4. Withstand voltage : 250VAC ;
5. Insertion and extraction force : 3-20N
6. life test : 5,000 cycles °

MODEL NO.	PJ-2804D-S125	PJ-2803D-S125
SCHEMATIC		

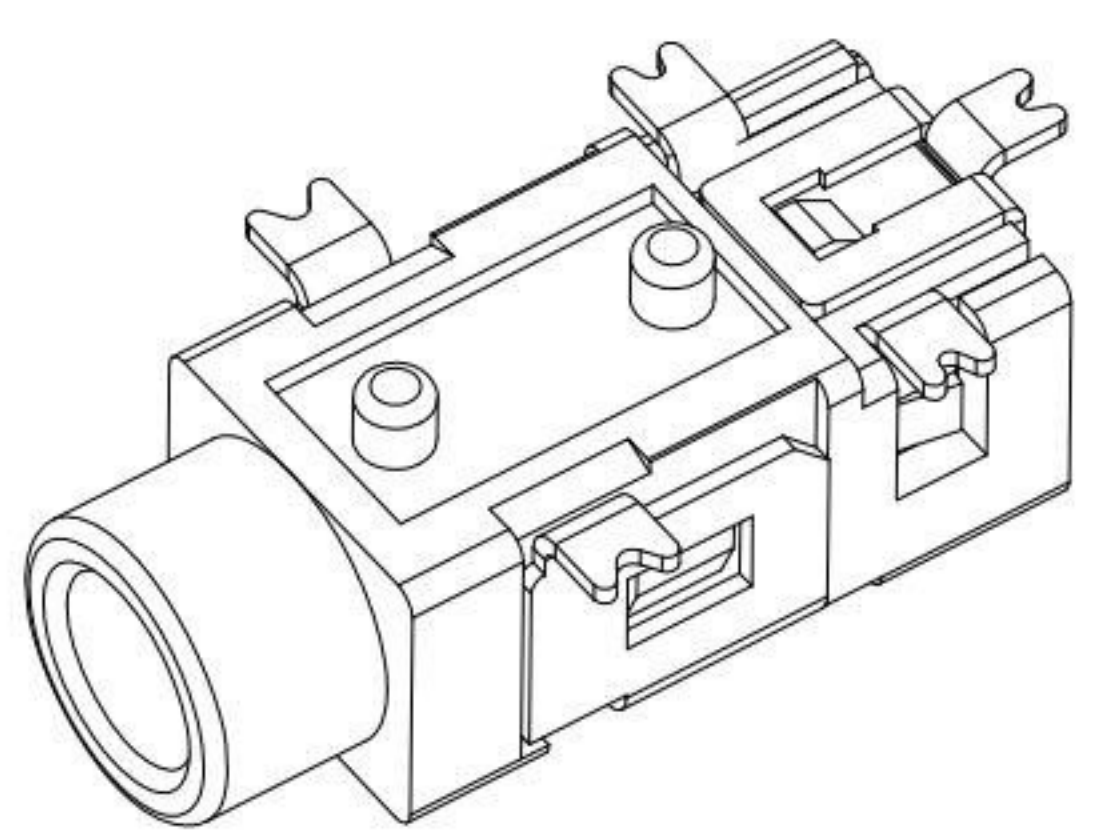
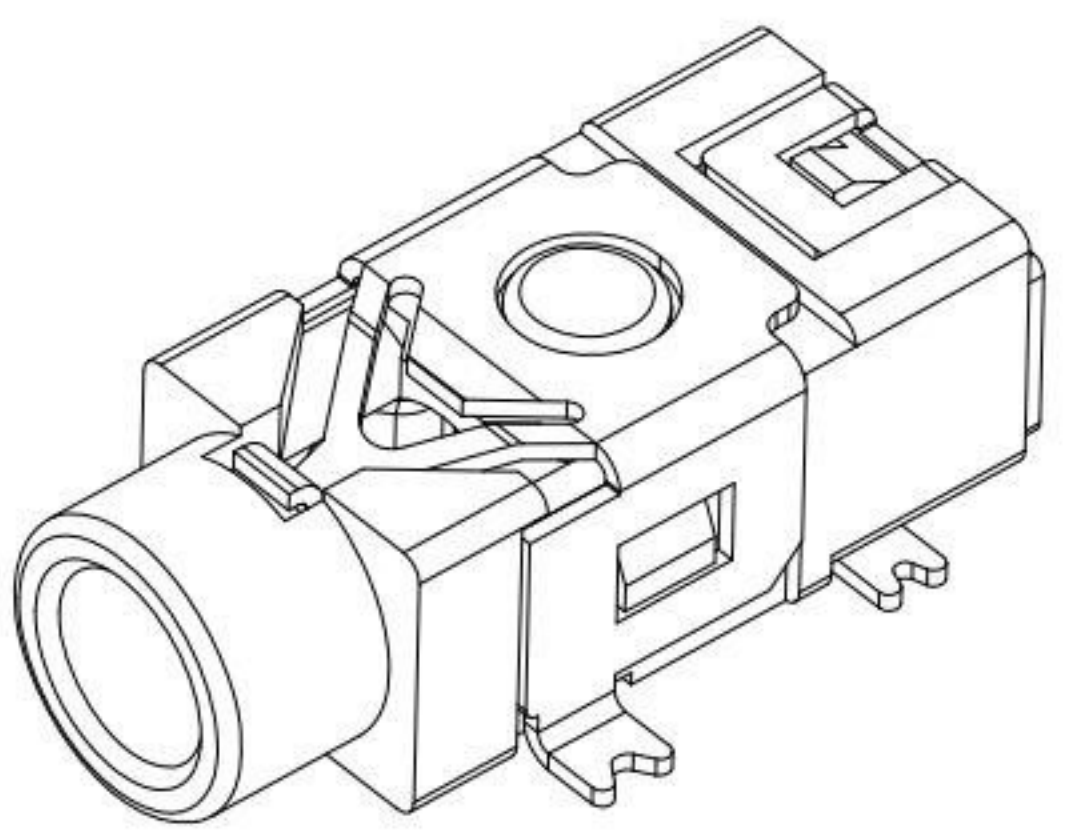

NO.	DESCRIPTION	QTY	MATERIAL	PLATING
5	HOUSING	1	PA9T	
4	CURVE PIECE	1	Brass	Au-Plating
3	SPRING PIECE	1	Phosphor Bronze	Au-Plating
2	SPRING PIECE	1	Phosphor Bronze	Au-Plating
1	CONTACT FOOT	1	Phosphor Bronze	Au-Plating

KSD 科斯达电子科技有限公司
SWITCH CONNECTOR 全球 互联零组件制造企业
KSD ELECTRONIC TECHNOLOGY Co., LTD

TOLERANCE UNLESS OTHERWISE STATED:
Up to 5 ±0.2
Above 5 ~ 15 ±0.3
Above 15 ~ 30 ±0.4
Above 30 ~ 50 ±0.5
Angle ±0.3°

3RD. ANGEL'S

UNITS MM

ITEM NO.	DESCRIPTION	DRAWN	DATE
2	更新Withstand voltage	Jack	072213
1	尺寸更正(6.8mm為6.4mm)	FrankWu	062512

DRAWN BY:	DATE	MAT'L	TITLE	JACK
Jack Lu	07/22/13		MODLE	PHONE JACK
CHECKED BY:	DATE	FINISH	DWG NO.	PJ-280xD-S125
Jacky Chen	07/22/13		PART NO.	PJ-280xD-S125
APPROVED BY:	DATE	SCALE	SHEET NO.	1 of 1
Tony Kao	07/22/13	1:1	SIZE	A4
			VER	R2