

P.C.B LAYOUT

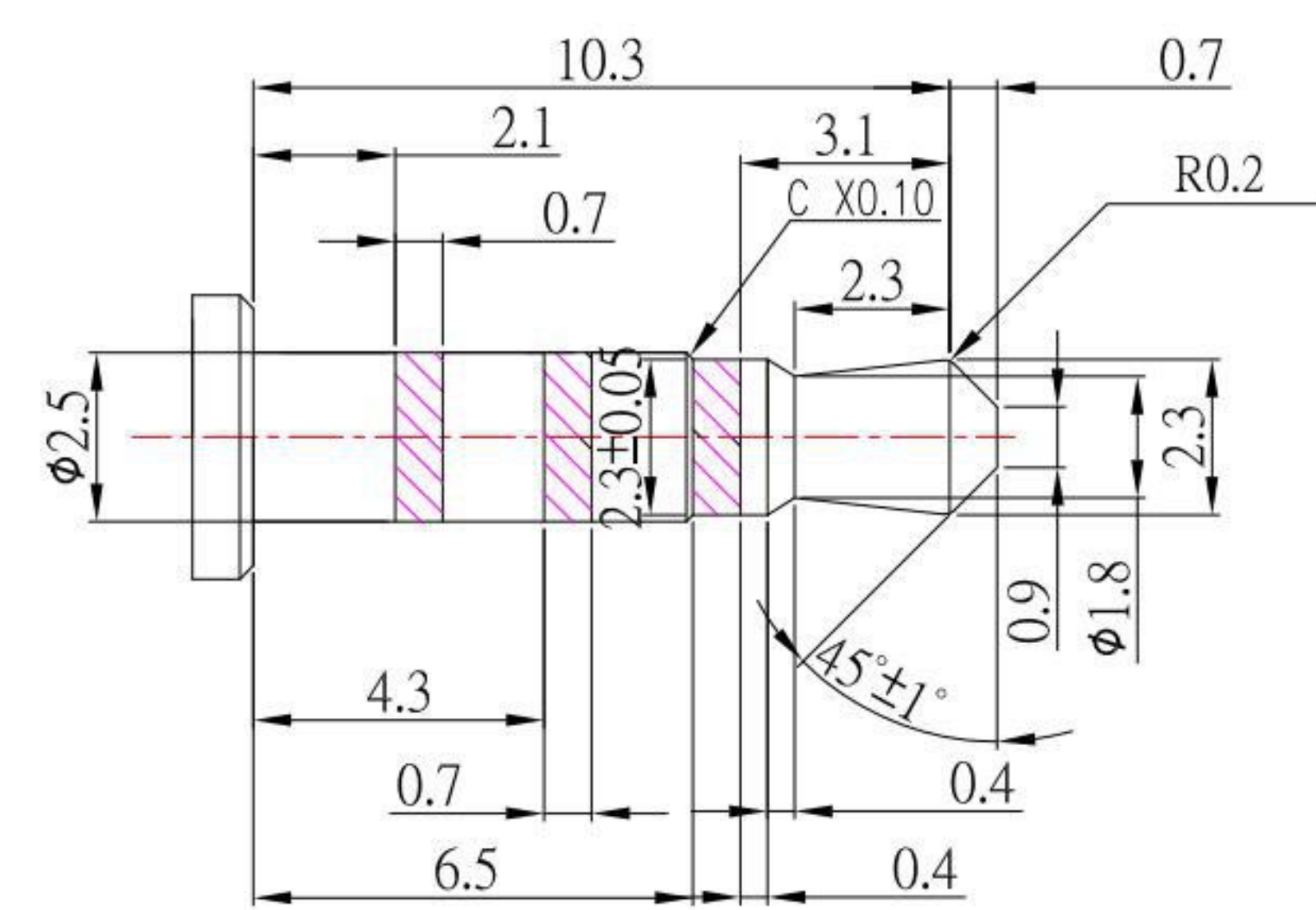

SPECIFICATION

- 1. Rating : DC 50V 0.3A
- 2. Contact resistance : $\leq 30m\Omega$
- 3. Insulation resistance : $\geq 100M\Omega$
- 4. Withstand voltage : 500VAC
- 5. Insertion and extraction force : 3-30N
- 6. life test : 5,000 cycles

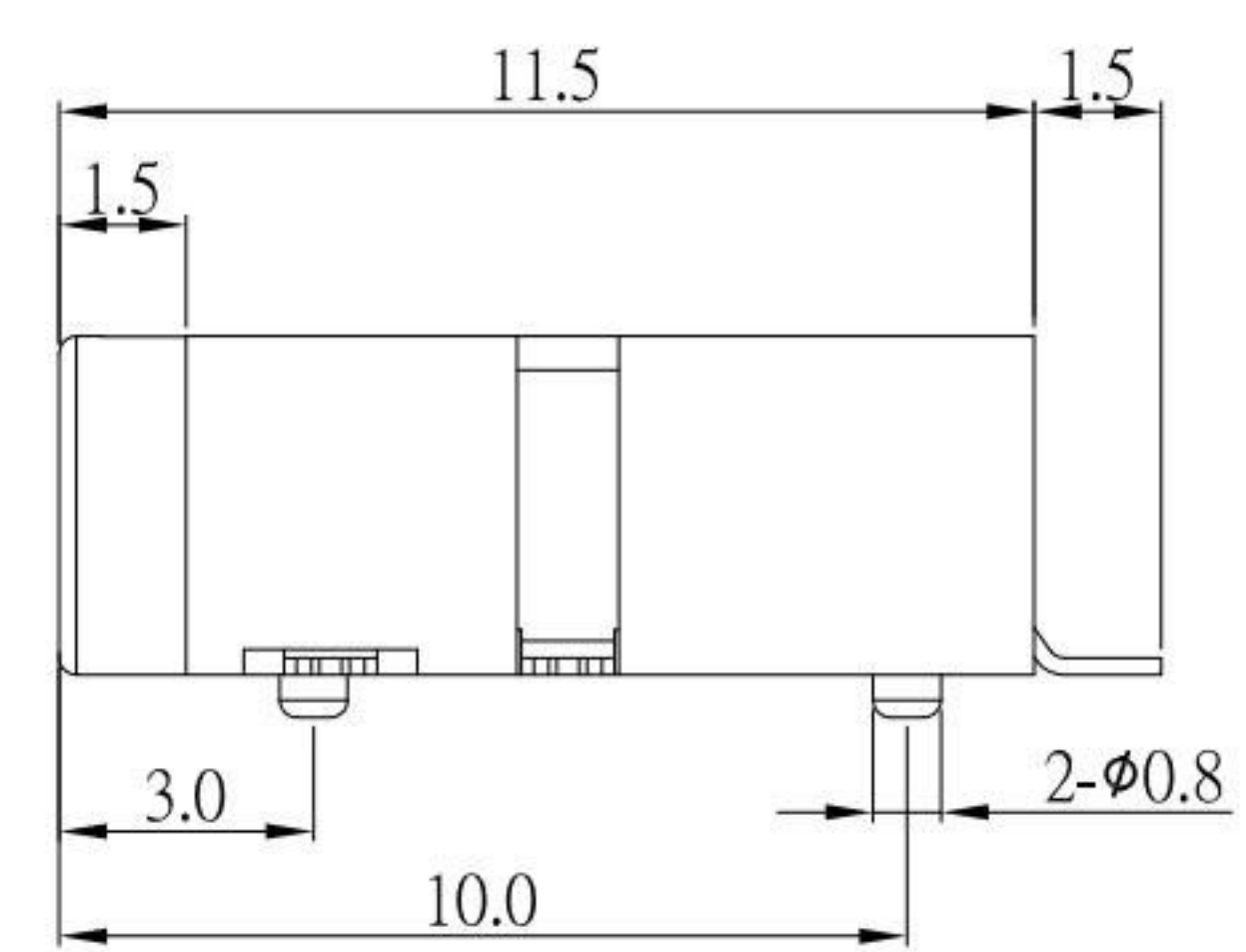
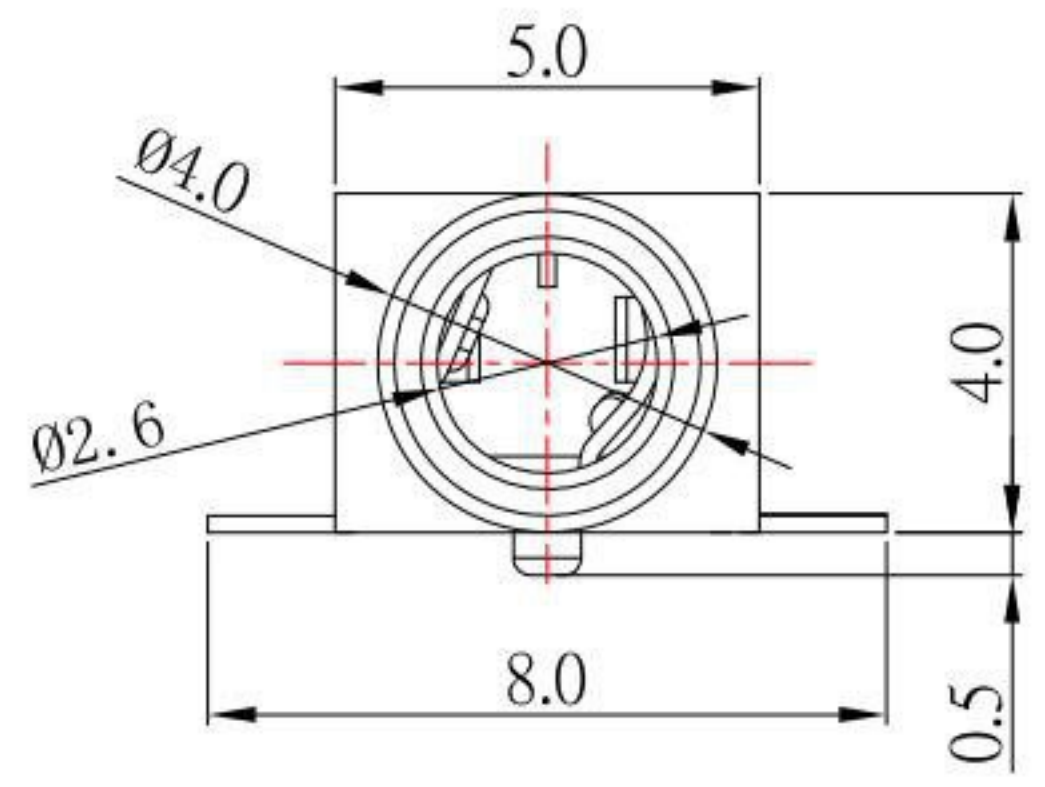
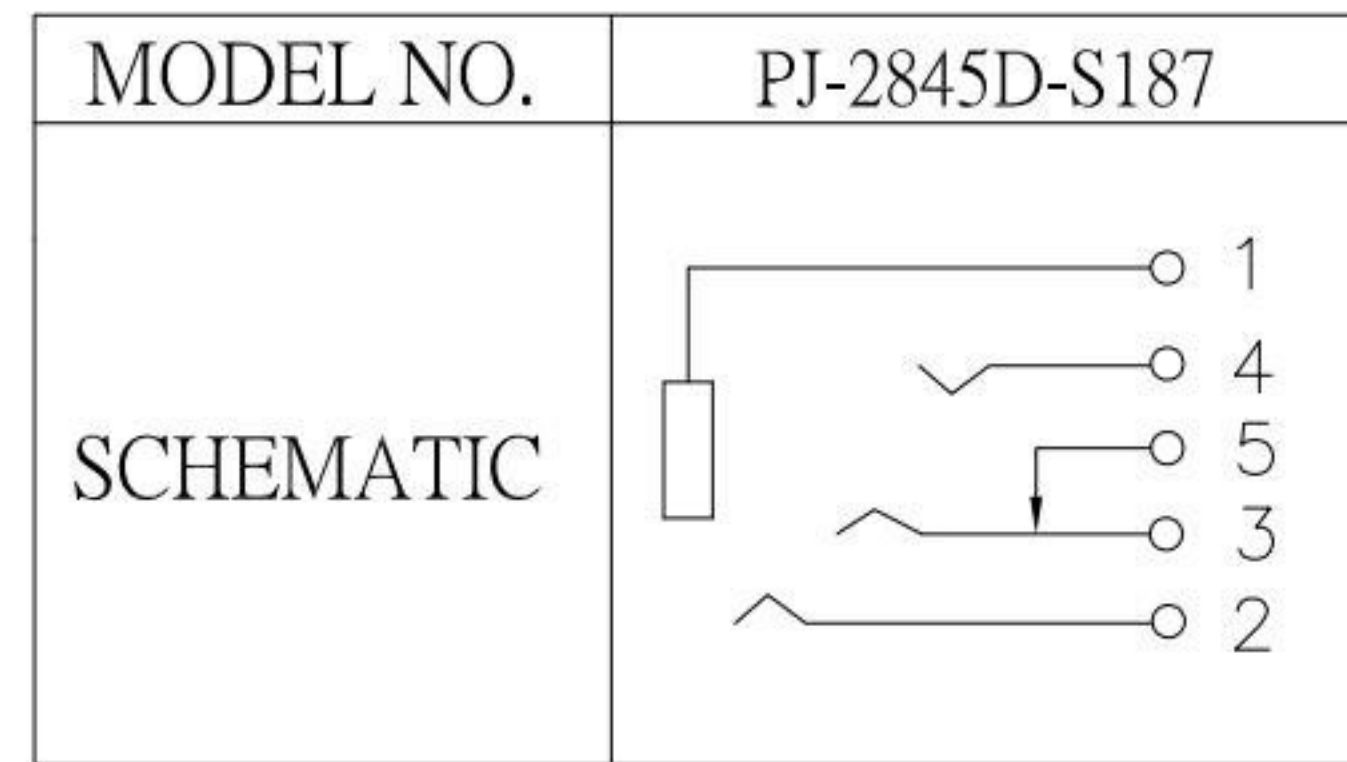

No.	PART NAME	QTY	MATERIAL (THICK, COLOR)	REMARK
⑥	HOUSING	1	PA-9T (Black)	
⑤	TERMINAL #5	1	PHOSPHOR BRONZE	Ag-Plated
④	TERMINAL #4	1	PHOSPHOR BRONZE	Ag-Plated
③	TERMINAL #3	1	PHOSPHOR BRONZE	Ag-Plated
②	TERMINAL #2	1	PHOSPHOR BRONZE	Ag-Plated
①	TERMINAL #1	1	PHOSPHOR BRONZE	Ag-Plated

KSD 科斯达电子科技有限公司
 SWITCH CONNECTOR KSD ELECTRONIC TECHNOLOGY Co., LTD
 全球 互连零组件 制造企业

TOLERANCE UNLESS OTHERWISE STATED :	Up to 5 ±0.2	3RD. ANGEL'S	UNITS	MM
	Above 5 ~ 15 ±0.3			
	Above 15 ~ 30 ±0.4			
	Above 30 ~ 50 ±0.5			
	Angle			±0.3°

ITEM NO.	DESCRIPTION	DRAWN	DATE
2	新增SPEC	Jack	110415
1	更新料號	Jack	041814

DRAWN BY:	DATE	MAT'L	TITLE	JACK
Jack Lu	11/04/15			
CHECKED BY:	DATE	FINISH	MODLE	PHONE JACK
Jacky Chen	11/04/15			
APPROVED BY:	DATE	SCALE	DWG NO.	PJ-2845D-S187
Tony Kao	11/04/15	1:1		
		SHEET NO.	PART NO.	PJ-2845D-S187
		1 of 1		

SIZE	A4
VER	R2