

P.C.B LAYOUT MOUNTING PATTERN (TOP VIEW)

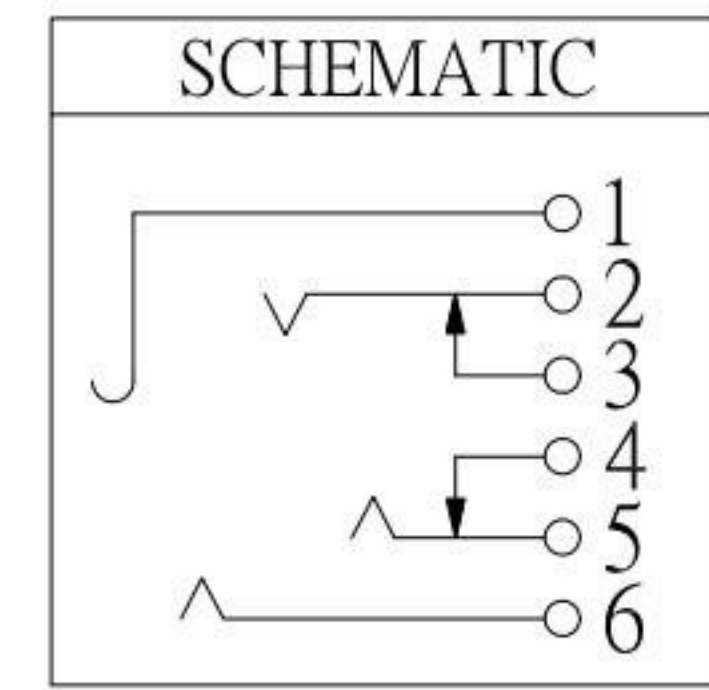

- SPECIFICATION**
- 1. Rating: DC 30V, 1.0A
 - 2. Contact resistance: $\leq 50m\Omega$
 - 3. Insulation resistance: $\geq 100M\Omega$
 - 4. Withstand voltage: 500VAC
 - 5. Insertion and extraction force: 3-20N
 - 6. life test: 5,000 cycles

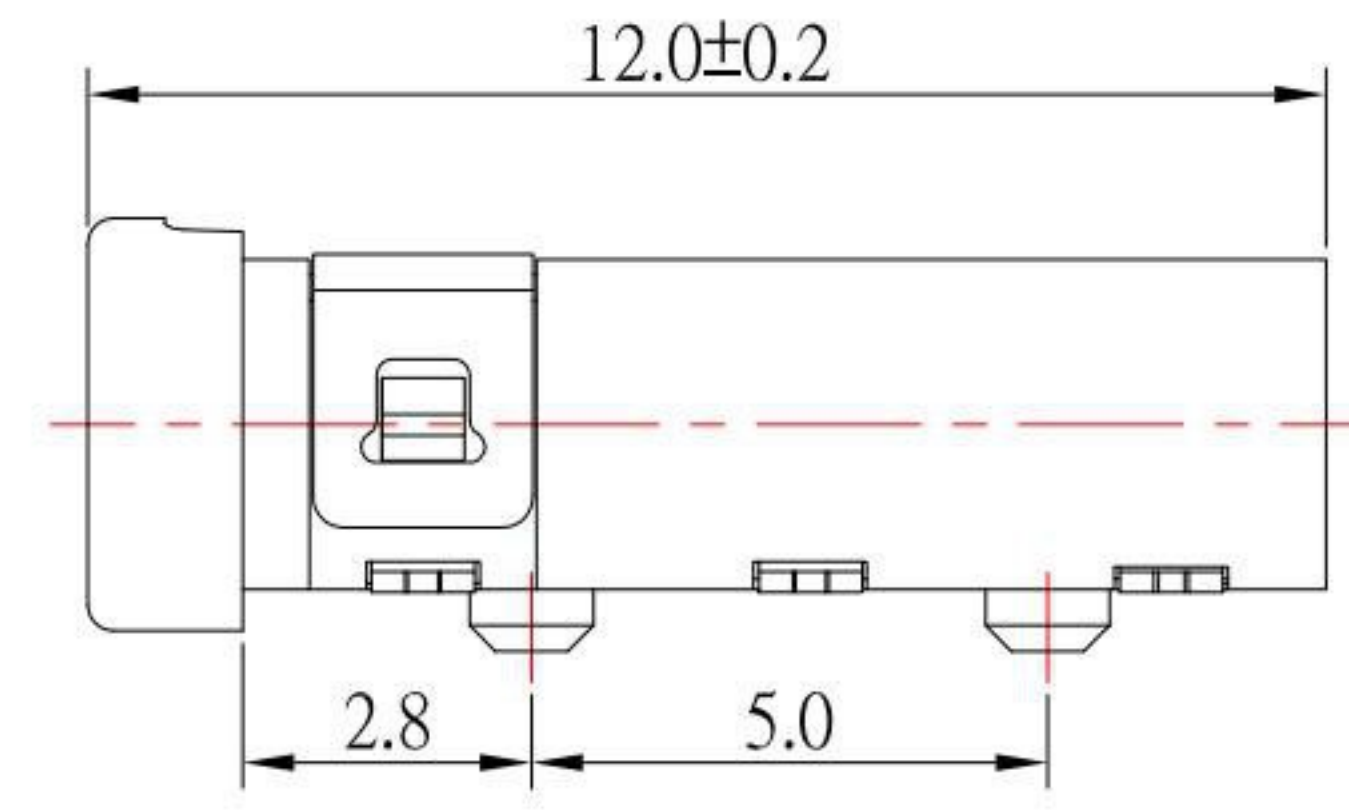
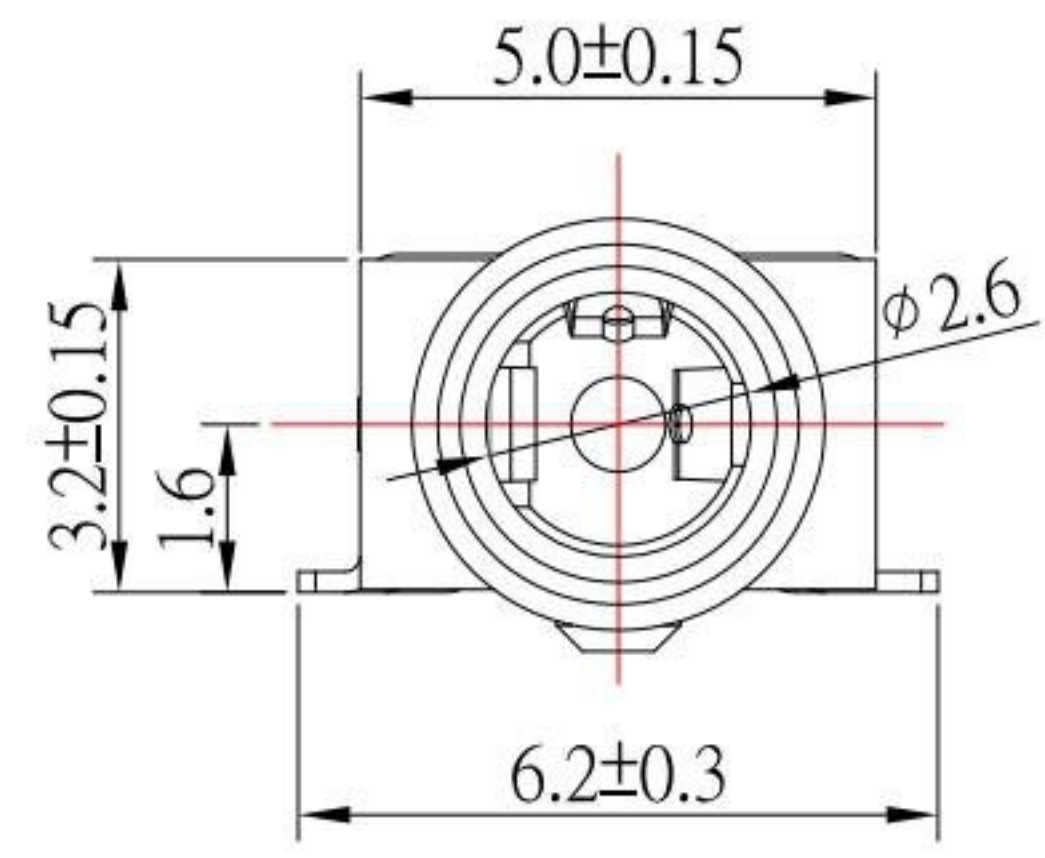
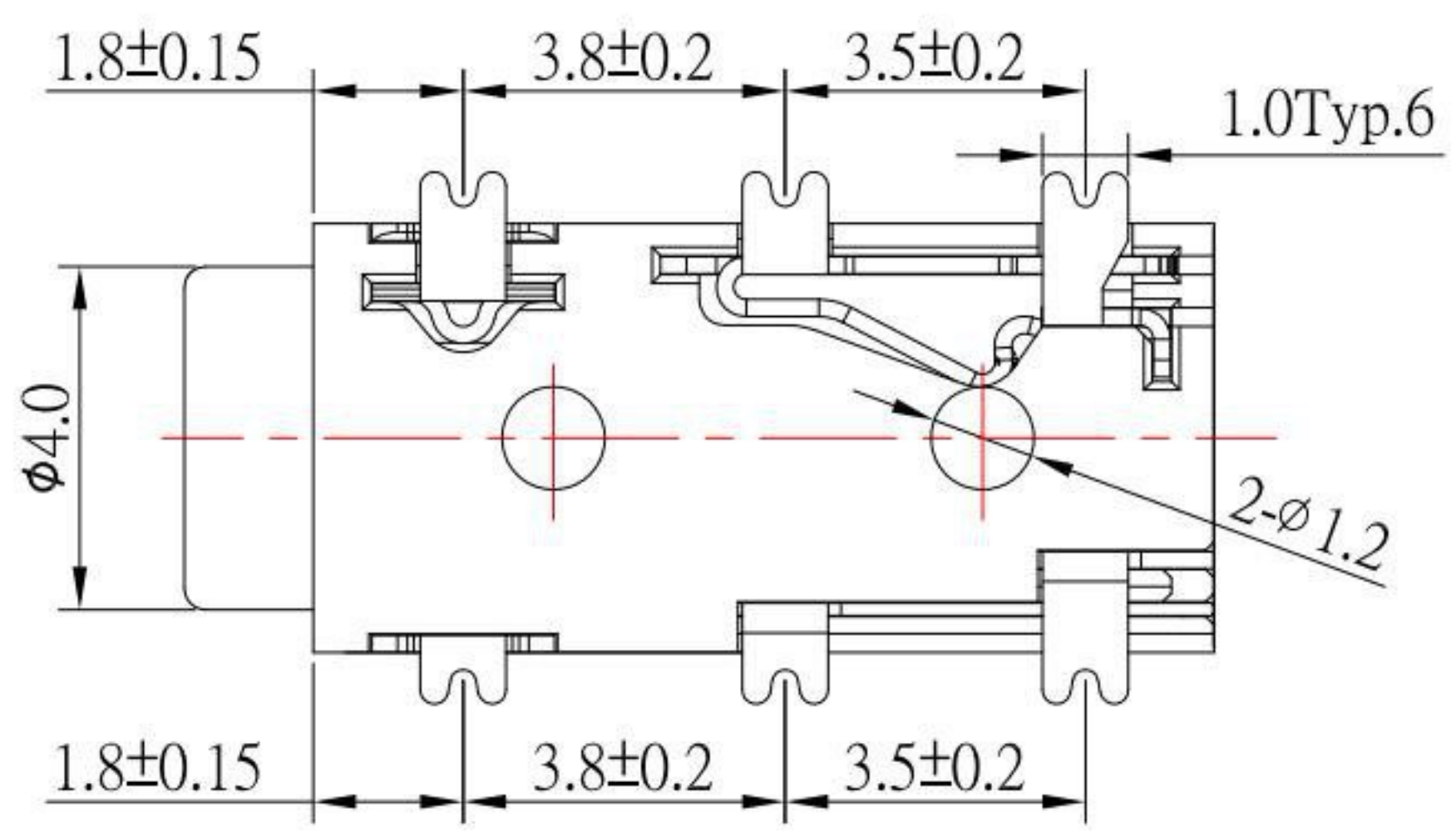
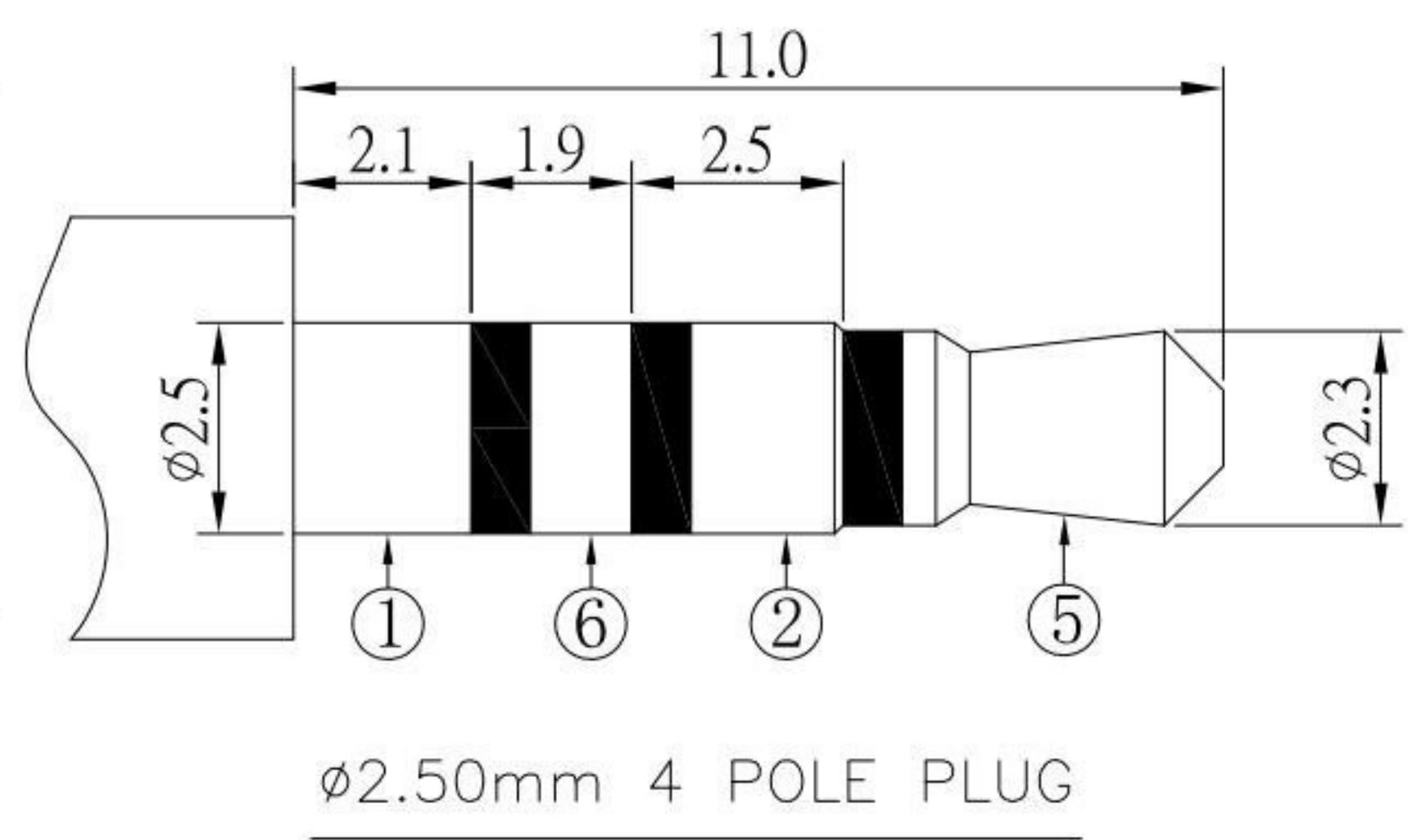

NO.	DESCRIPTION	QTY	MATERIAL	REMARK
⑦	HOUSING	1	PA9T	
⑥	CONTACT FOOT #6	1	Phosphor Bronze	Au Plated over Ni
⑤	CONTACT FOOT #5	1	Phosphor Bronze	Au Plated over Ni
④	CONTACT FOOT #4	1	Phosphor Bronze	Au Plated over Ni
③	CONTACT FOOT #3	1	Phosphor Bronze	Au Plated over Ni
②	CONTACT FOOT #2	1	Phosphor Bronze	Au Plated over Ni
①	CONTACT FOOT #1	1	Phosphor Bronze	Au Plated over Ni

KSD 科斯达电子科技有限公司
 SWITCH CONNECTOR KSD ELECTRONIC TECHNOLOGY Co., LTD
 全球 互联零组件制造企业

TOLERANCE UNLESS OTHERWISE STATED:
 Up to 5 ±0.2
 Above 5 ~ 15 ±0.3
 Above 15 ~ 30 ±0.4
 Above 30 ~ 50 ±0.5
 Angle ±0.3°

3RD. ANGEL'S

UNITS MM

DRAWN BY:	DATE	MAT'L	TITLE	JACK
Jack Lu	10/26/21			
CHECKED BY:	DATE	FINISH	MODLE	PHONE JACK
Jacky Chen	10/26/21			
APPROVED BY:	DATE	SCALE	DWG NO.	PJ-2866D-H3-S124
Tony Kao	10/26/21	1:1		
		SHEET NO.	PART NO.	PJ-2866D-H3-S124
		1 of 1		

ITEM NO.	DESCRIPTION	DRAWN	DATE
2	更新鍍層	Jack	102621
1	更新圖面	Jack	010821

SIZE A4
 VER R2