

SPECIFICATION

1. Rating : DC 30V 0.5A ;
2. Contact resistance : $\leq 50m\Omega$;
3. Insulation resistance : $\geq 100M\Omega$ (DC250V) ;
4. Withstand voltage : 500VAC ;
5. Insertion and extraction force : 3-20N;
6. life test : 5,000 cycles °

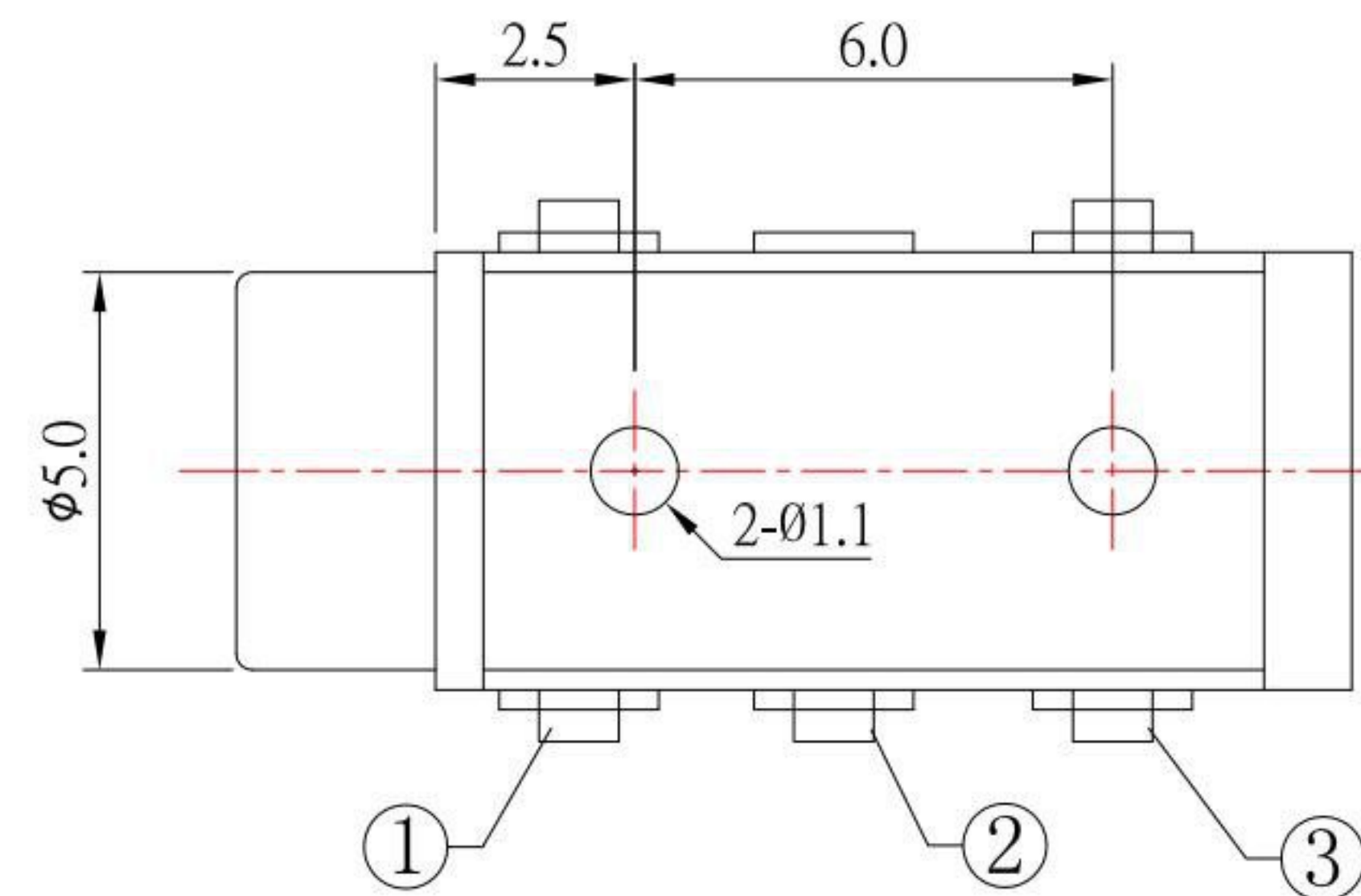

SCHEMATIC

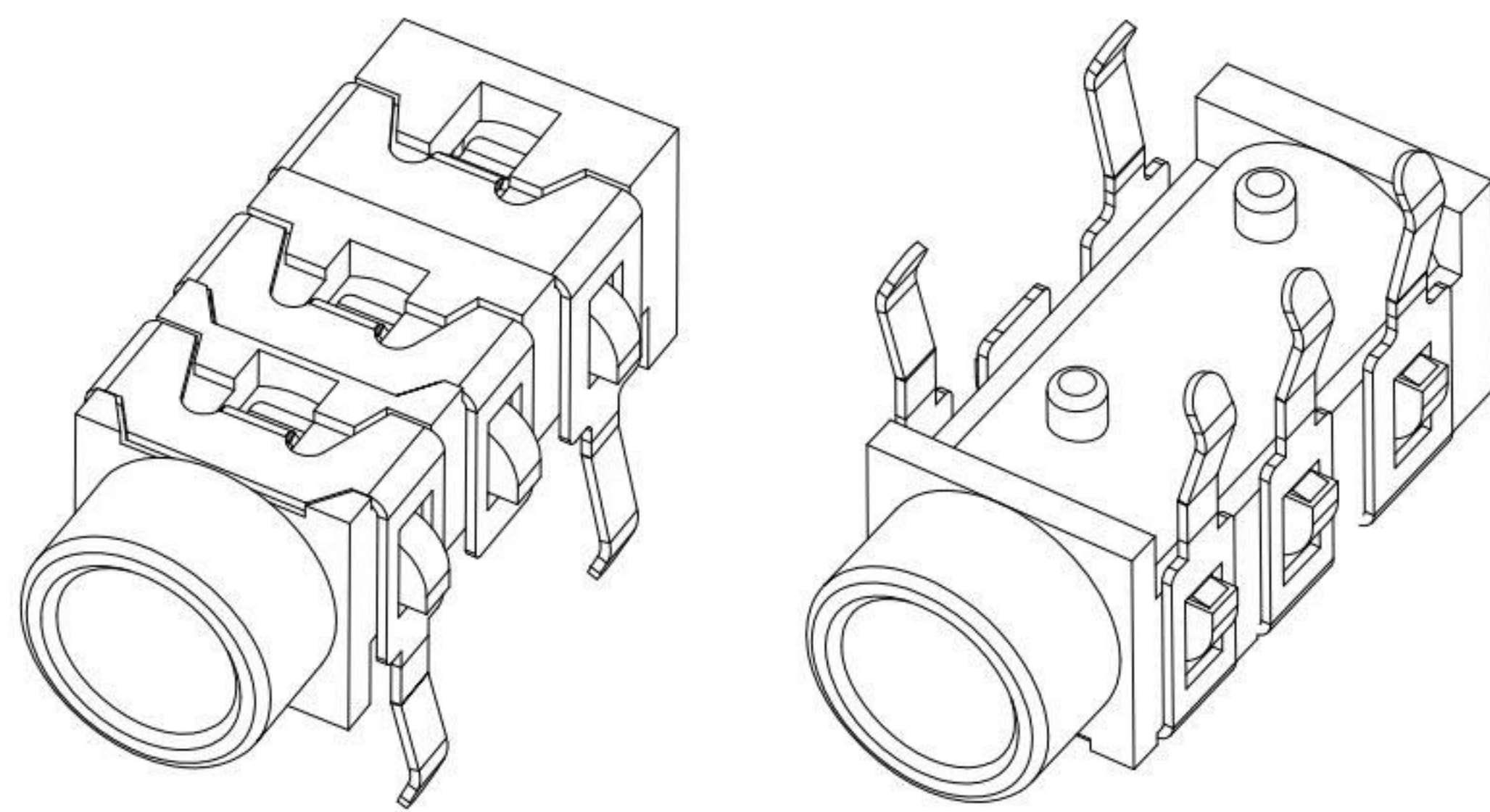
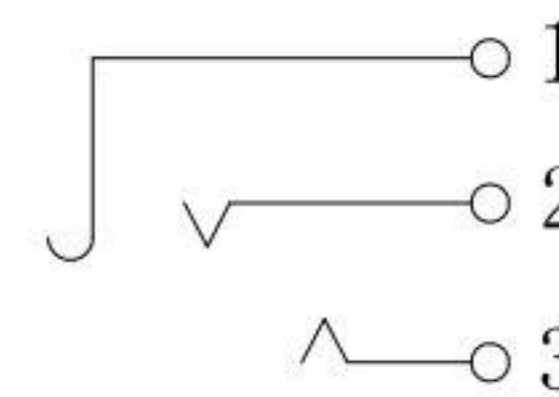

NO.	DESCRIPTION	QTY	MATERIAL	PLATING
4	HOUSING	1	PBT	
3	CONTACT FOOT	1	SUS301	Sn-Plating
2	CONTACT FOOT	1	SUS301	Sn-Plating
1	CONTACT FOOT	1	SUS301	Sn-Plating

KSD 科斯达电子科技有限公司
 SWITCH CONNECTOR KSD ELECTRONIC TECHNOLOGY Co., LTD
 全球 互联零组件制造企业

TOLERANCE UNLESS OTHERWISE STATED:
 Up to 5 ±0.2
 Above 5 ~ 15 ±0.3
 Above 15 ~ 30 ±0.4
 Above 30 ~ 50 ±0.5
 Angle ±0.3°

3RD. ANGEL'S

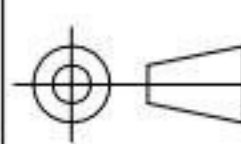

UNITS MM

DRAWN BY:	DATE	MAT'L	TITLE	JACK
Jack Lu	05/20/14			
CHECKED BY:	DATE	FINISH	MODLE	PHONE JACK
Jacky Chen	05/20/14			
APPROVED BY:	DATE	SCALE	DWG NO.	PJ-354-S125
Tony Kao	05/20/14	1:1		
SHEET NO.	1 of 1	PART NO.	PJ-354-S125	

SIZE A4
 VER R1

ITEM NO.	DESCRIPTION	DRAWN	DATE
1	更新SPEC	Jack	052014