

PJ-364x-x-S124

| COLOR |
|--------------|
| Black: Blank |
| PINK : PI |
| Green : GR |
| Blue : BL |

SCHEMATIC

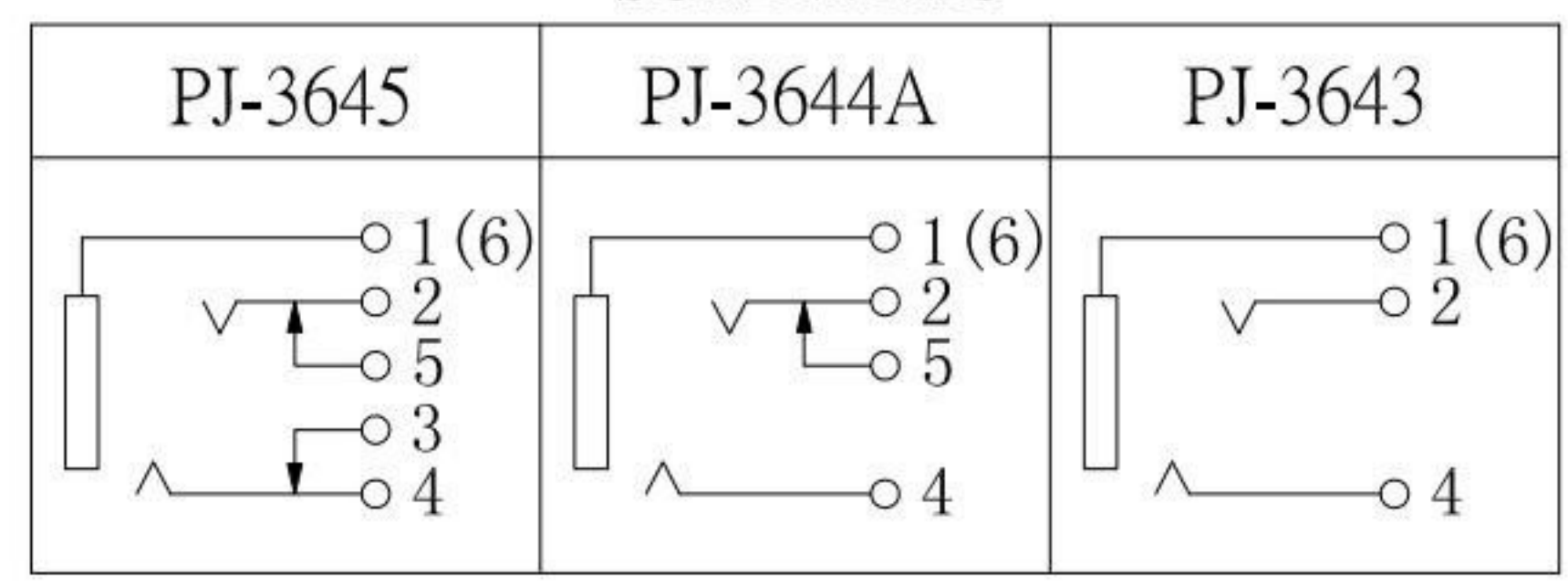

SPECIFICATION

- 1.Rating : DC 30V 0.5A ;
- 2.Contact resistance : $\leq 0.03 \Omega$;
- 3.Insulation resistance : $\geq 100M\Omega$;
- 4.Withstand voltage : 500VAC ;
- 5.Insertion and extraction force : 3-30N;
- 6.life test : 5,000 cycles °

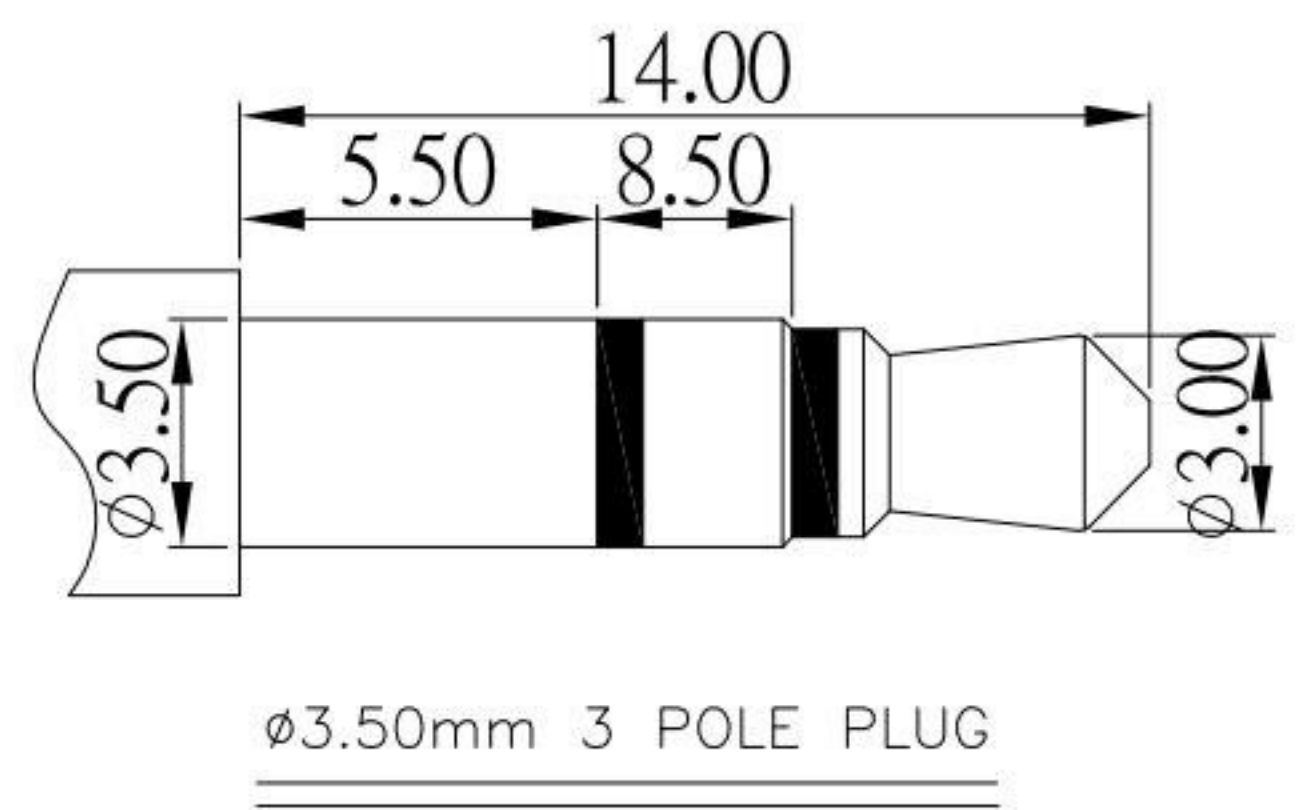
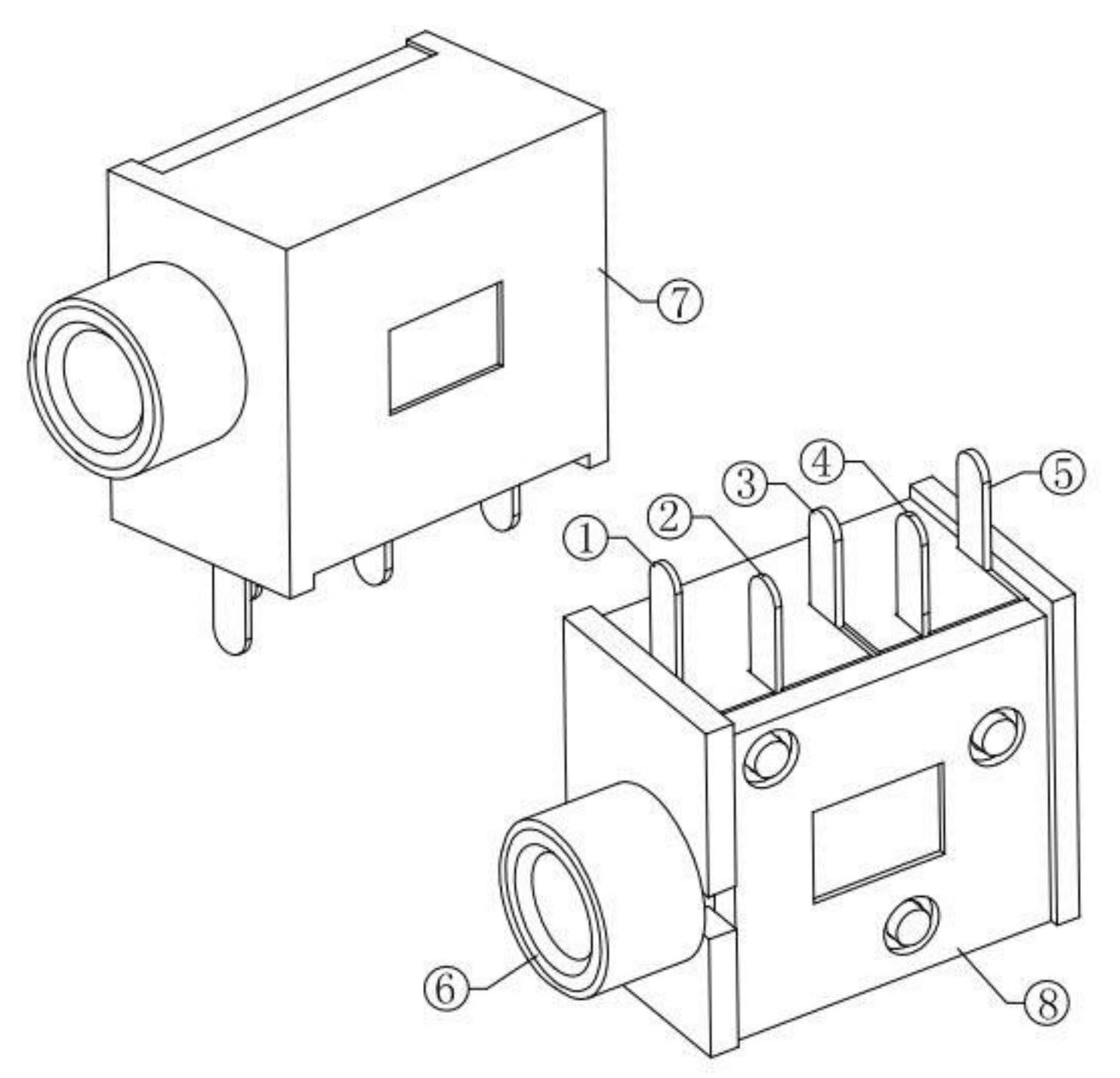

| NO. | DESCRIPTION | QTY | MATERIAL | PLATING |
|-----|--------------|-----|-----------------|------------|
| 8 | COVER | 1 | PBT | |
| 7 | HOUSING | 1 | PBT | |
| 6 | AXIS SUPPORT | 1 | BRASS | Ni-Plating |
| 5 | CURVE PIECE | 1 | BRASS | Sn-Plating |
| 4 | SPRING PIECE | 1 | PHOSPHOR BRONZE | Sn-Plating |
| 3 | CURVE PIECE | 1 | BRASS | Sn-Plating |
| 2 | SPRING PIECE | 1 | PHOSPHOR BRONZE | Sn-Plating |
| 1 | FLAT PIECE | 1 | BRASS | Sn-Plating |

KSD 科斯达电子科技有限公司
 SWITCH CONNECTOR KSD ELECTRONIC TECHNOLOGY Co., LTD
 全球 互联网 零组件 制造企业

TOLERANCE UNLESS OTHERWISE STATED:
 Up to 5 ±0.2
 Above 5 ~ 15 ±0.3
 Above 15 ~ 30 ±0.4
 Above 30 ~ 50 ±0.5
 Angle ±0.3

3RD. ANGEL'S

UNITS MM

| | | | |
|------------------------|----------------|--------------------------|-------------------------|
| DRAWN BY: Jack Lu | DATE: 03/03/17 | MAT'L | TITLE: JACK |
| CHECKED BY: Jacky Chen | DATE: 03/03/17 | FINISH | MODLE: PHONE JACK |
| APPROVED BY: Tony Kao | DATE: 03/03/17 | SCALE: 1:1 | DWG NO.: PJ-364x-x-S124 |
| SHEET NO.: 1 of 1 | | PART NO.: PJ-364x-x-S124 | SIZE: A4 |
| | | | VER: R |

| ITEM NO. | DESCRIPTION | DRAWN | DATE |
|----------|-------------|-------|------|
| | | | |