

P.C.B LAYOUT
TOP VIEW

SCHEMATIC

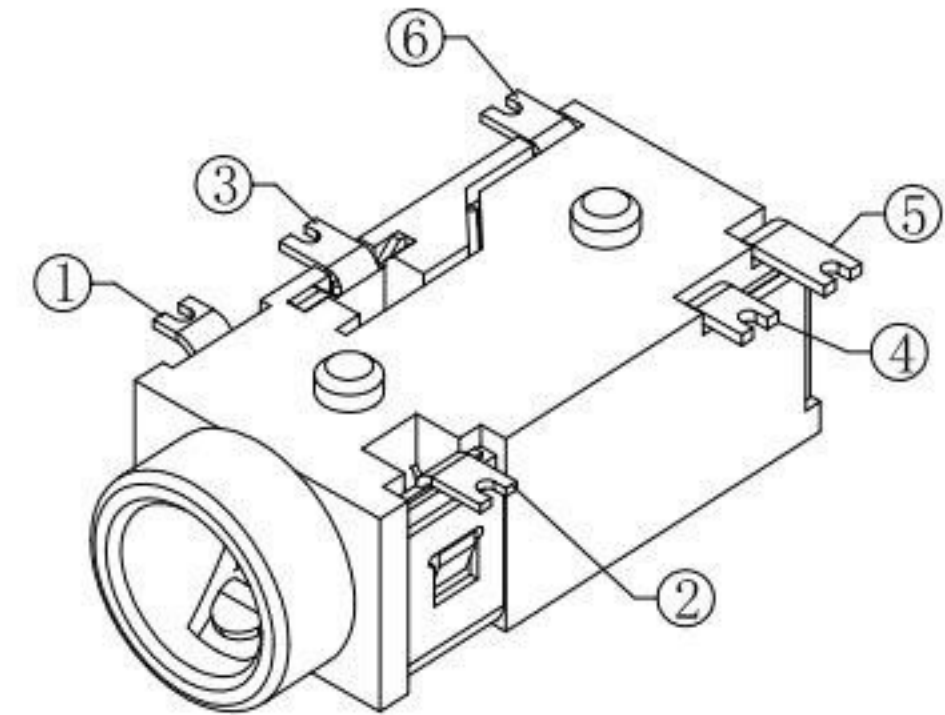

NO.	DESCRIPTION	QTY	MATERIAL	PLATING
7	HOUSING	1	PA9T	
6	6# CONTACT FOOT	1	PHOSPHOR BRONZE	Ag-Plating
5	5# CONTACT FOOT	1	PHOSPHOR BRONZE	Ag-Plating
4	4# CONTACT FOOT	1	PHOSPHOR BRONZE	Ag-Plating
3	3# CONTACT FOOT	1	PHOSPHOR BRONZE	Ag-Plating
2	2# CONTACT FOOT	1	PHOSPHOR BRONZE	Ag-Plating
1	1# CONTACT FOOT	1	PHOSPHOR BRONZE	Ag-Plating

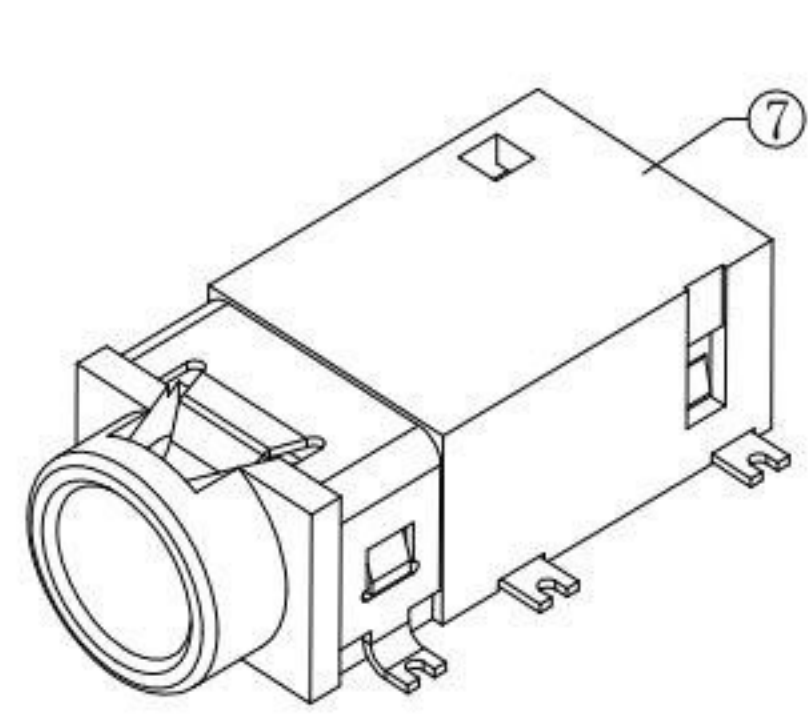
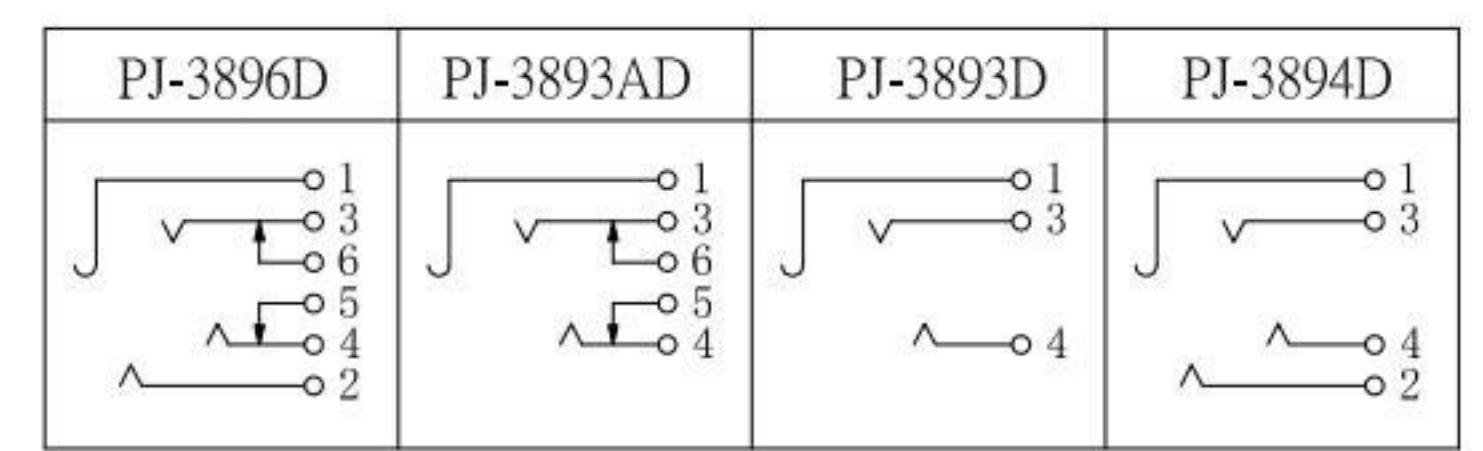
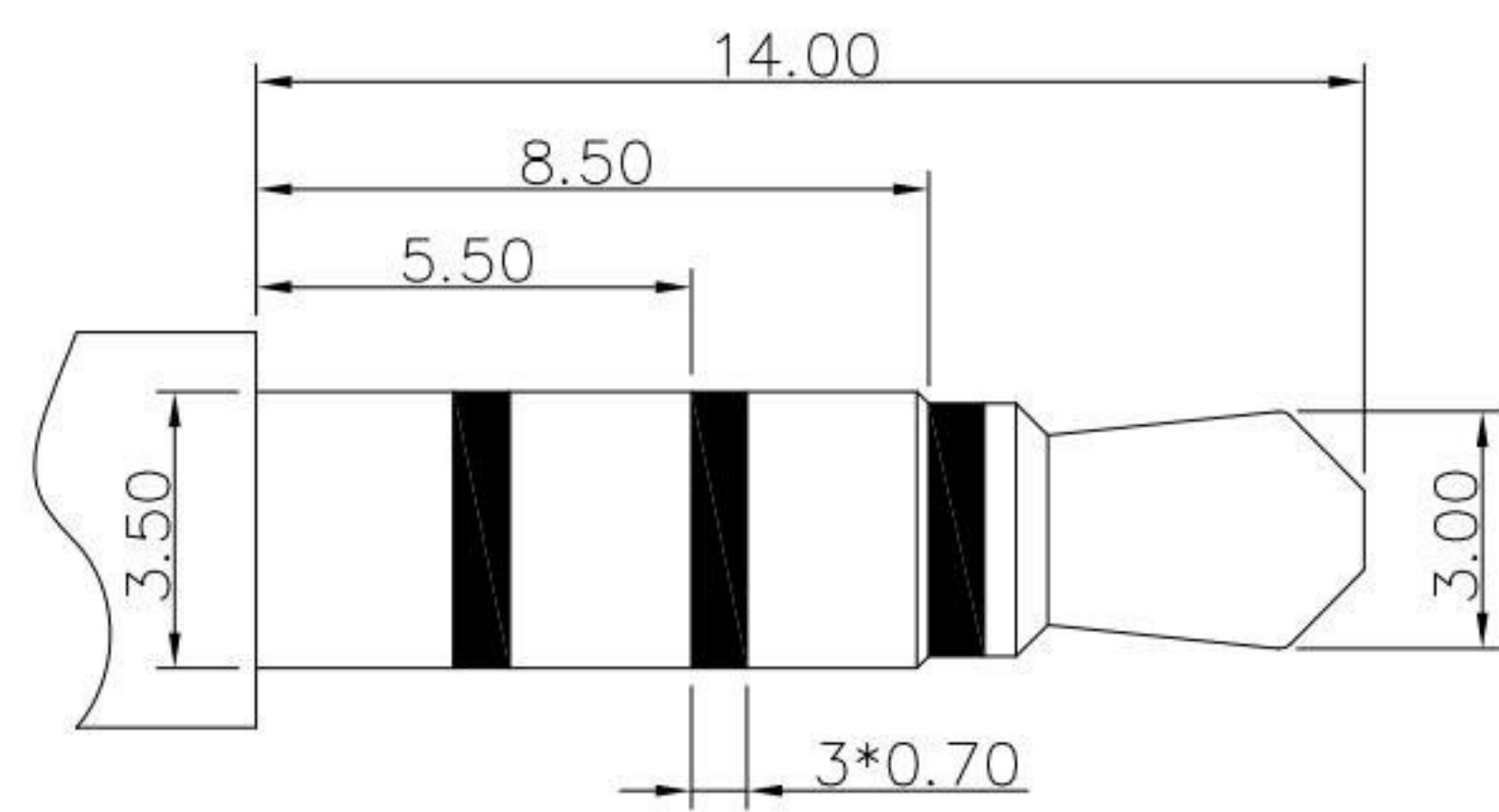

φ3.50mm 4 POLE PLUG

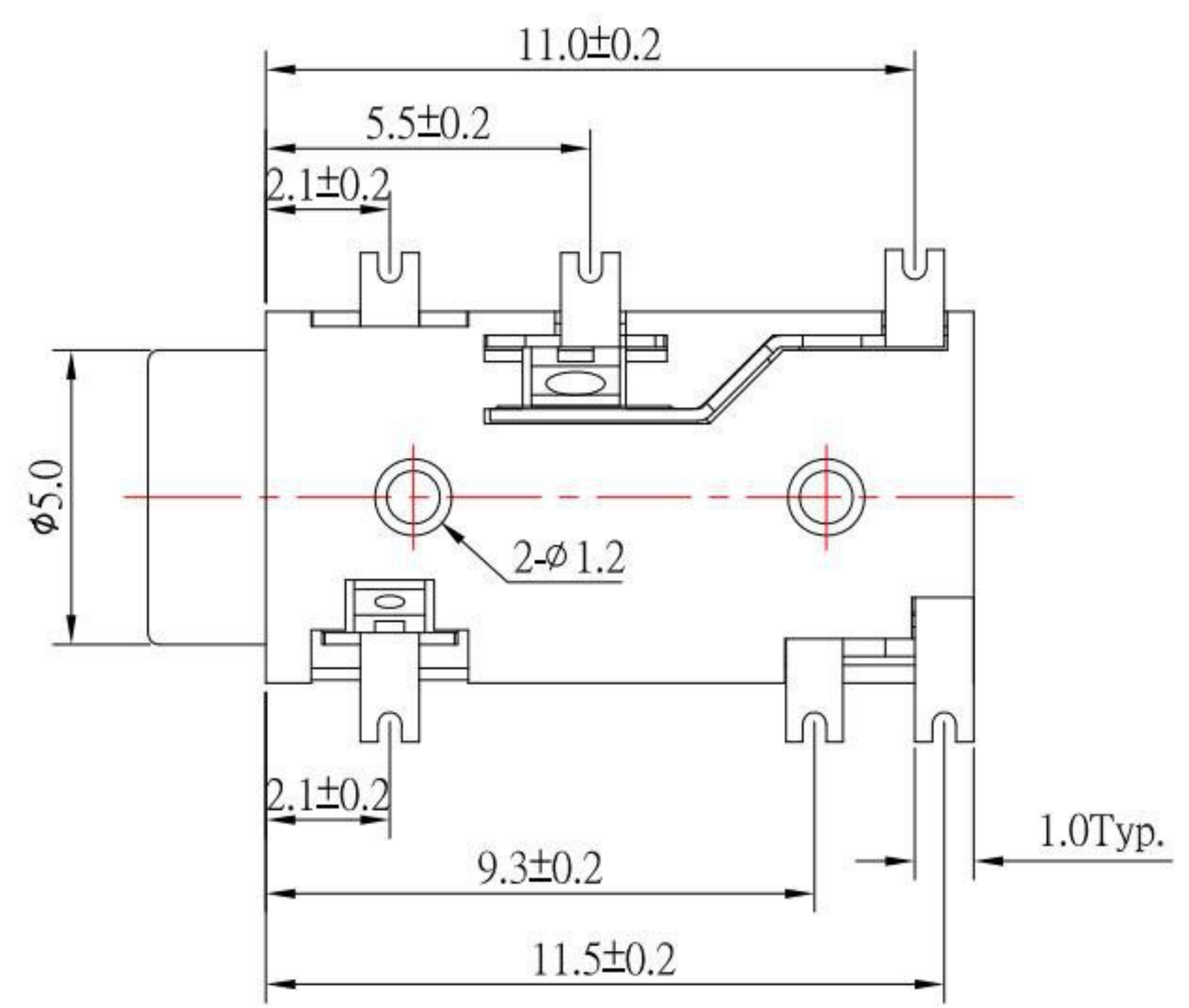

SPECIFICATION

1. Rating : DC 30V 0.5A
2. Contact resistance : ≤30mΩ
3. Insulation resistance : ≥100MΩ
4. Withstand voltage : 500VAC
5. Insertion and extraction force : 3-30N
6. life test : 5,000 cycles ◦

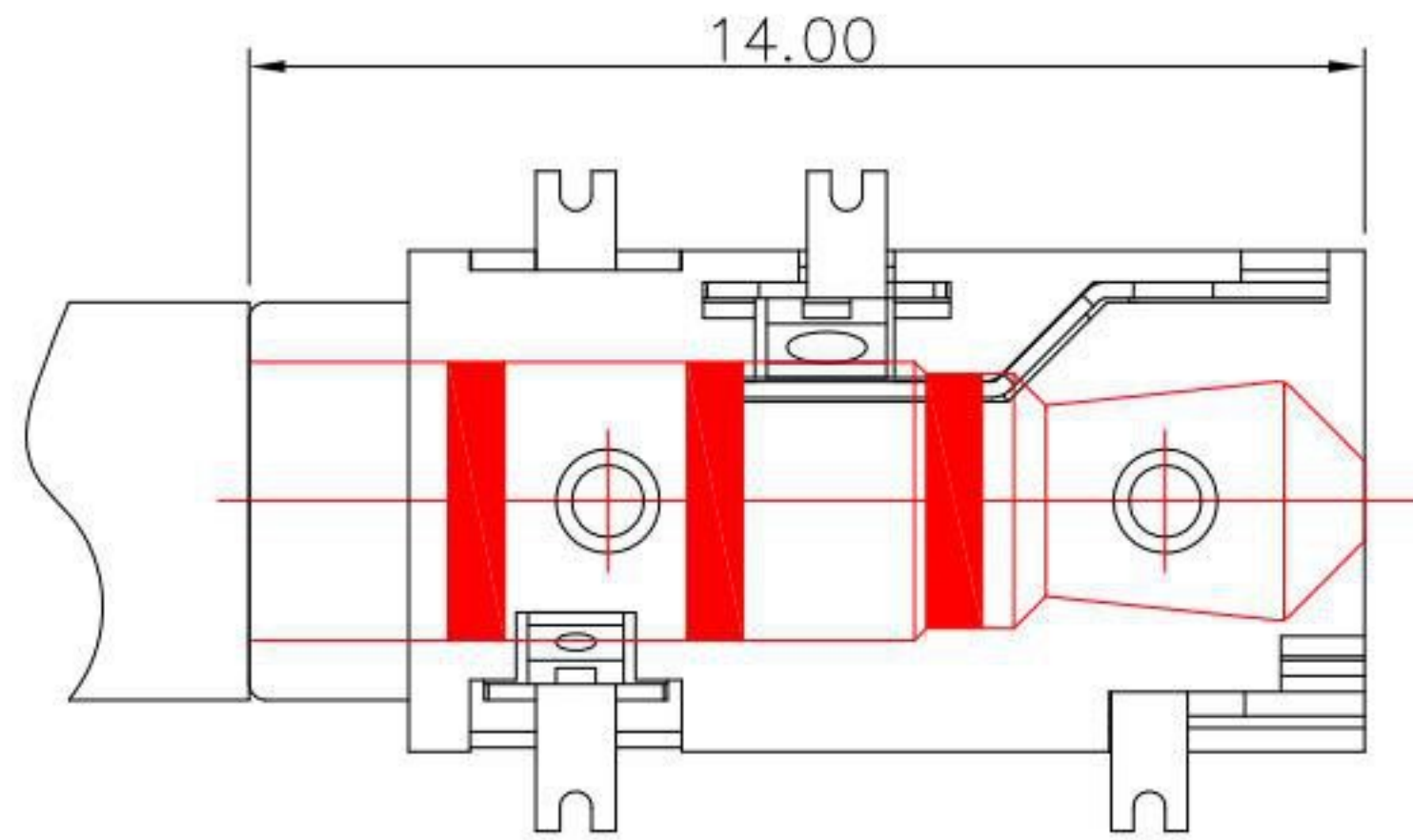

KSD 科斯达电子科技有限公司
SWITCH CONNECTOR 全球 互联零组件制造企业
KSD ELECTRONIC TECHNOLOGY Co., LTD

TOLERANCE UNLESS OTHERWISE STATED:	Up to 5 ±0.2	Above 5 ~ 15 ±0.3	Above 15 ~ 30 ±0.4	Above 30 ~ 50 ±0.5	Angle ±0.3
	3RD. ANGEL'S	UNITS	MM		

DRAWN BY:	DATE	MAT'L	TITLE	JACK
Jack Lu	04/11/22		MODLE	PHONE JACK
CHECKED BY:	DATE	FINISH	DWG NO.	PJ-389xD-S124
Jacky Chen	04/11/22		PART NO.	PJ-389xD-S124
APPROVED BY:	DATE	SCALE	1:1	
Tony Kao	04/11/22	SHEET NO.	1 of 1	

ITEM NO.	DESCRIPTION	DRAWN	DATE
3	更新材質和SCHEMATIC選項	Jack	041122
2	新增插入示意圖	Jack	060817
1	更新為A0版	Jack	031317