

P.C.B LAYOUT
TOP VIEW

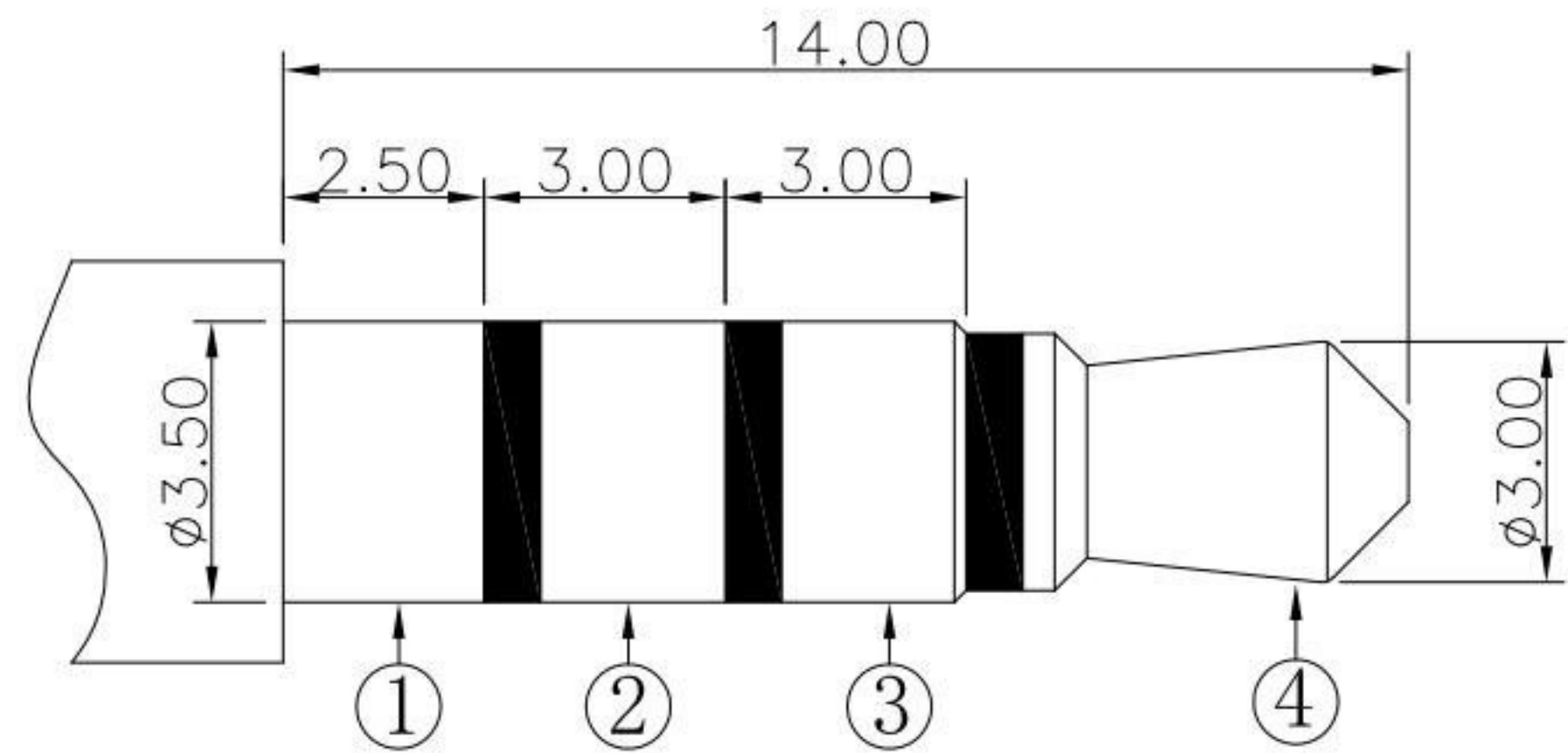

ø3.50mm 4 POLE PLUG

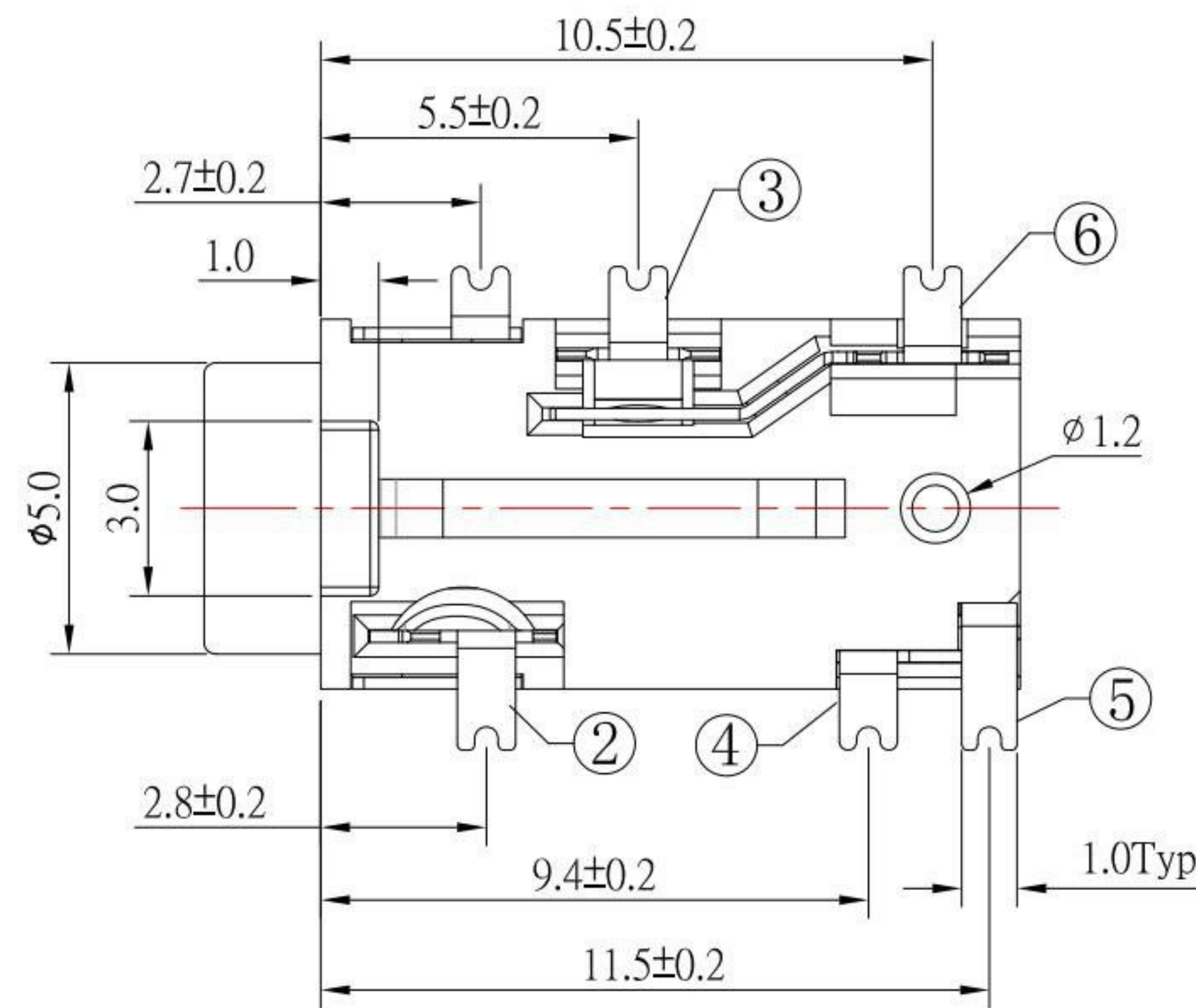

SCHMATIC

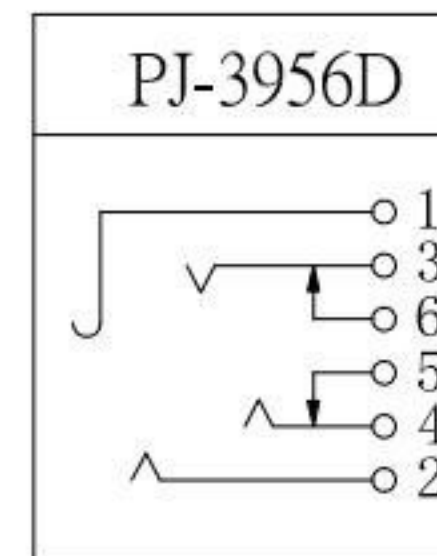

SPECIFICATION

- 1. Rating : DC 30V 0.5A ;
- 2. Contact resistance : $\leq 30m\Omega$;
- 3. Insulation resistance : $\geq 100M\Omega$;
- 4. Withstand voltage : 500VAC ;
- 5. Insertion and extraction force : 3-20N;
- 6. life test : 5,000 cycles °

NO.	DESCRIPTION	QTY	MATERIAL	PLATING
7	HOUSING	1	PA9T	
6	6# CONTACT FOOT	1	PHOSPHOR BRONZE	Au-Plating
5	5# CONTACT FOOT	1	PHOSPHOR BRONZE	Au-Plating
4	4# CONTACT FOOT	1	PHOSPHOR BRONZE	Au-Plating
3	3# CONTACT FOOT	1	PHOSPHOR BRONZE	Au-Plating
2	2# CONTACT FOOT	1	PHOSPHOR BRONZE	Au-Plating
1	1# CONTACT FOOT	1	PHOSPHOR BRONZE	Au-Plating

KSD 科斯达电子科技有限公司
SWITCH CONNECTOR KSD ELECTRONIC TECHNOLOGY Co., LTD
全球 互联零组件制造企业

TOLERANCE UNLESS OTHERWISE STATED :
 Up to 5 ±0.2
 Above 5 ~ 15 ±0.3
 Above 15 ~ 30 ±0.4
 Above 30 ~ 50 ±0.5
 Angle ±0.3°

3RD. ANGEL'S

UNITS MM

DRAWN BY:	DATE	MAT'L	TITLE	JACK
Jack Lu	12/17/19			
CHECKED BY:	DATE	FINISH	MODLE	PHONE JACK
Jacky Chen	12/17/19			
APPROVED BY:	DATE	SCALE	DWG NO.	PJ-3956D-S124
Tony Kao	12/17/19	1:1		
SHEET NO.		1 of 1	PART NO.	PJ-3956D-S124

ITEM NO.	DESCRIPTION	DRAWN	DATE
1	更新樣式	Jack	121719

SIZE A4
VER R1