

P.C.B LAYOUT MOUNTING PATTERN
(TOP VIEW)

MODEL NO.	PJ-D3022-S124
SCHEMATIC	

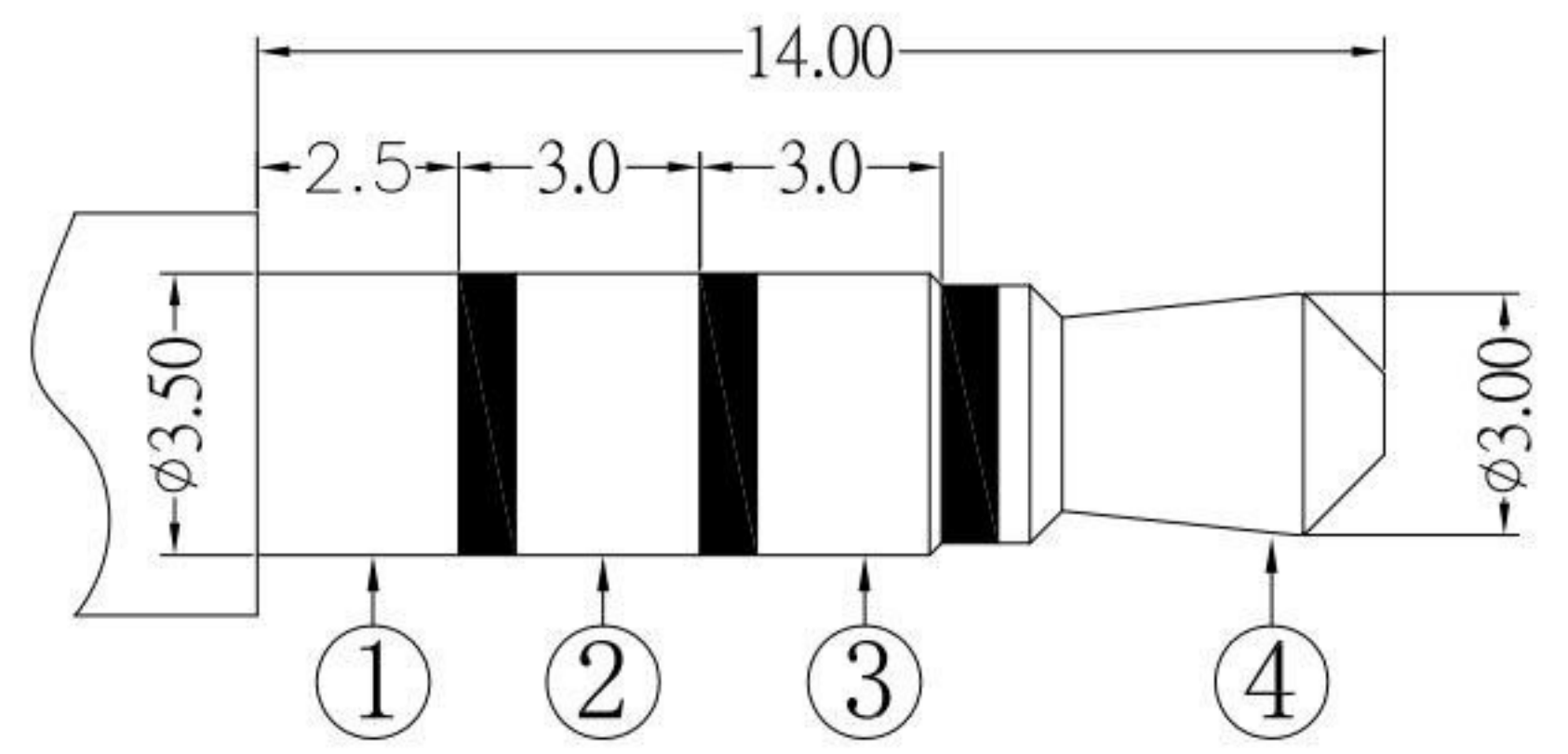
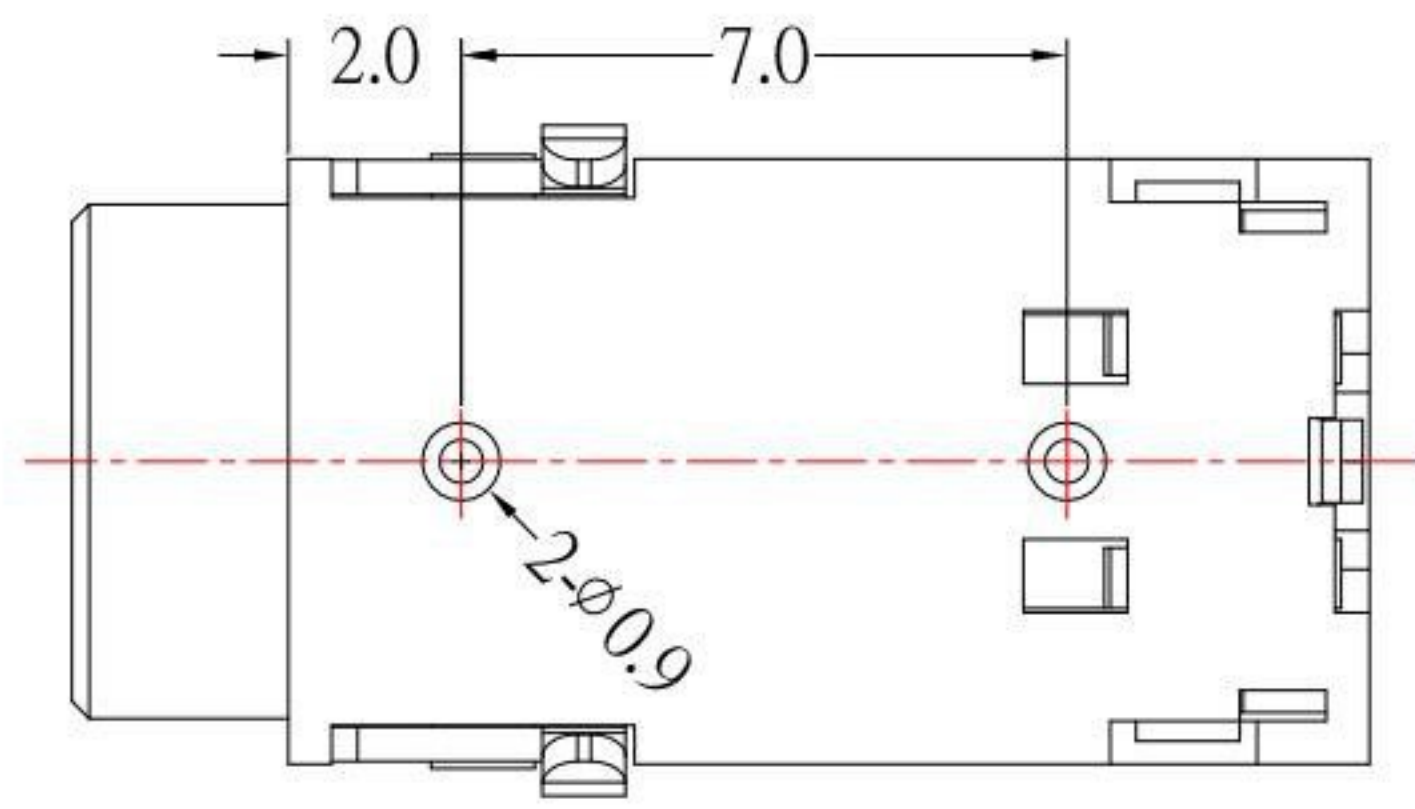

φ3.50mm 4 POLE PLUG

SPECIFICATION

1. Rating : DC 30V , 1.0A ;
2. Contact resistance : ≤ 30mΩ ;
3. Insulation resistance : ≥ 100MΩ ;
4. Withstand voltage : 500VAC ;
5. Insertion and extraction force : 3-20N
6. life test : 10,000 cycles °

5	HOUSING	1	PBT	
4	CONTACT FOOT #4	1	Phosphor Bronze	Sn-Plating
3	CONTACT FOOT #3	1	Brass	Sn-Plating
2	CONTACT FOOT #2	1	Phosphor Bronze	Sn-Plating
1	CONTACT FOOT #1	1	Phosphor Bronze	Sn-Plating
NO.	DESCRIPTION	QTY	MATERIAL	PLATING

KSD 科斯达电子科技有限公司
SWITCH CONNECTOR KSD ELECTRONIC TECHNOLOGY Co., LTD
全球 互联零组件制造企业

TOLERANCE UNLESS OTHERWISE STATED:	Up to 5 ±0.2	Above 5 ~ 15 ±0.3	Above 15 ~ 30 ±0.4	Above 30 ~ 50 ±0.5	Angle ±0.3°	3RD. ANGEL'S	UNITS	MM
------------------------------------	--------------	-------------------	--------------------	--------------------	-------------	--------------	-------	----

DRAWN BY:	DATE	MAT'L	TITLE	JACK
Jack Lu	10/15/21		MODLE	PHONE JACK
CHECKED BY:	DATE	FINISH	DWG NO.	PJ-D3022-S124
Jacky Chen	10/15/21		PART NO.	PJ-D3022-S124
APPROVED BY:	DATE	SCALE	SHEET NO.	1 of 1
Tony Kao	10/15/21	1:1	SIZE	A4
			VER	R2

ITEM NO.	DESCRIPTION	DRAWN	DATE
2	更新尺寸公差	Jack	101521
1	更新為A0版	Jack	102616