

**SPECIFICATIONS**

1. Rating : DC 30V 0.5A ;
2. Contact resistance :  $\leq 0.03 \Omega$  ;
3. Insulation resistance :  $\geq 100M \Omega$  ;
4. Withstand voltage : 500VAC ;
5. Insertion and extraction force : 3-20N;
6. life test : 5,000 cycles °

**SCHEMATIC**

PJ-D3025	PJ-D3025-1	PJ-D3025-2	PJ-D3025-3	PJ-D3025-4

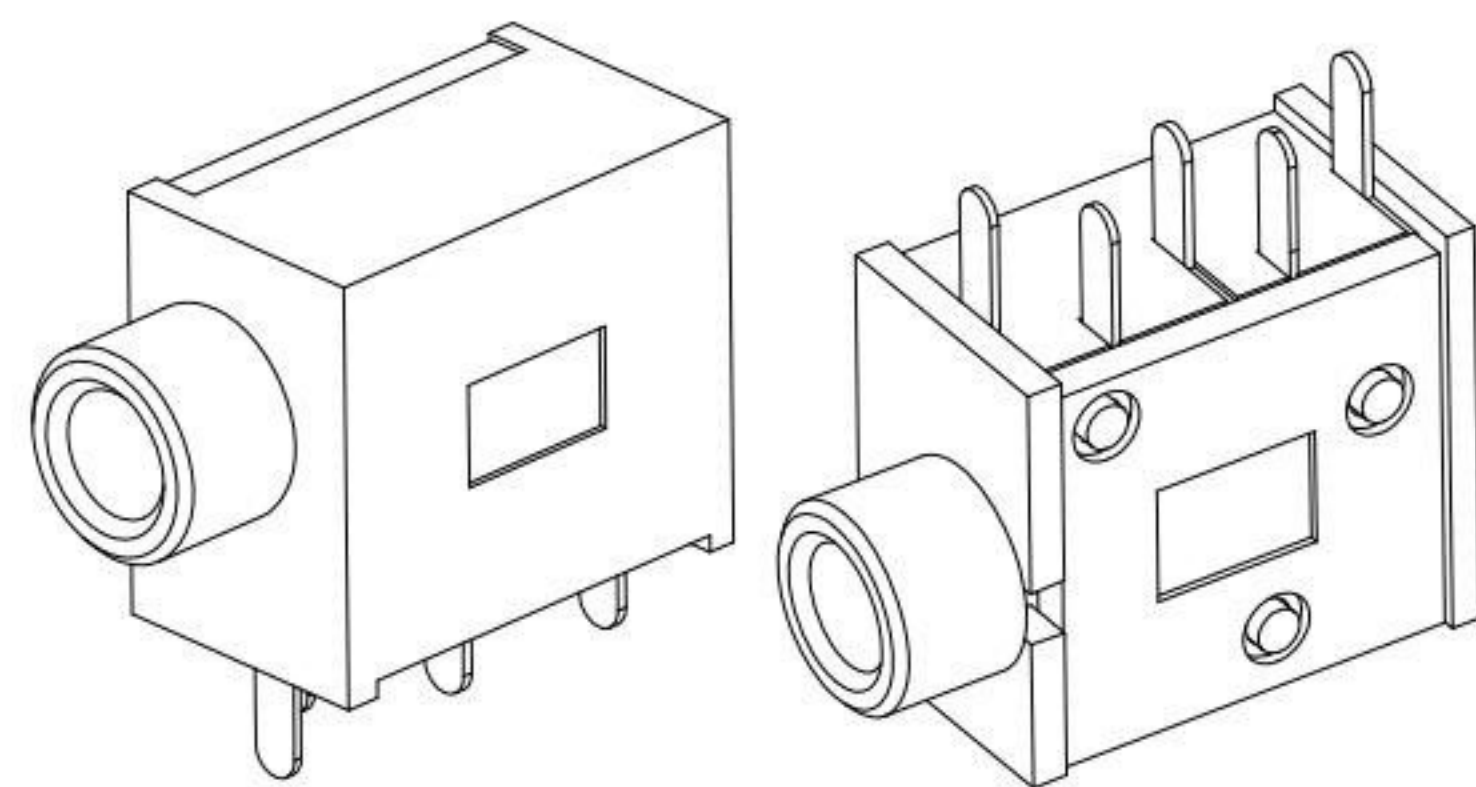

NO.	DESCRIPTION	QTY	MATERIAL	PLATING
⑧	COVER	1	PBT	
⑦	HOUSING	1	PBT	
⑥	AXIS SUPPORT	1	BRASS	Ni-Plating
⑤	CURVE PIECE	1	BRASS	Sn-Plating
④	SPRING PIECE	1	PHOSPHOR BRONZE	Sn-Plating
③	CURVE PIECE	1	BRASS	Sn-Plating
②	SPRING PIECE	1	PHOSPHOR BRONZE	Sn-Plating
①	FLAT PIECE	1	BRASS	Sn-Plating

**KSD** 科斯达电子科技有限公司  
 SWITCH CONNECTOR KSD ELECTRONIC TECHNOLOGY Co., LTD  
 全球 互联网 零组件 制造企业

TOLERANCE UNLESS OTHERWISE STATED :  
 Up to 5 ±0.2  
 Above 5 ~ 15 ±0.3  
 Above 15 ~ 30 ±0.4  
 Above 30 ~ 50 ±0.5  
 Angle ±0.3°

3RD. ANGEL'S

UNITS MM

DRAWN BY: Jack Lu DATE: 10/05/16  
 CHECKED BY: Jacky Chen DATE: 10/05/16  
 APPROVED BY: Tony Kao DATE: 10/05/16

MAT'L	TITLE	JACK
FINISH	MODLE	PHONE JACK
SCALE 1:1	DWG NO.	PJ-D3025-S124
SHEET NO. 1 of 1	PART NO.	PJ-D3025-S124

ITEM NO.	DESCRIPTION	DRAWN	DATE
1	更新為A0版	Jack	100516

SIZE A4  
 VER A0