

P.C.B LAYOUT  
TOP VIEW

SCHEMATIC

PJ-D3042	PJ-D3042-1	PJ-D3042-2

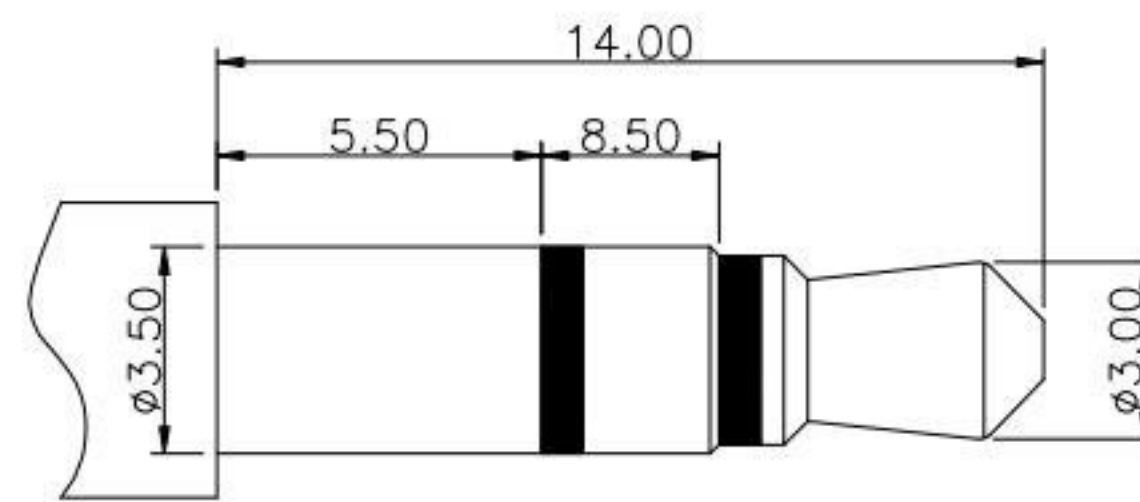
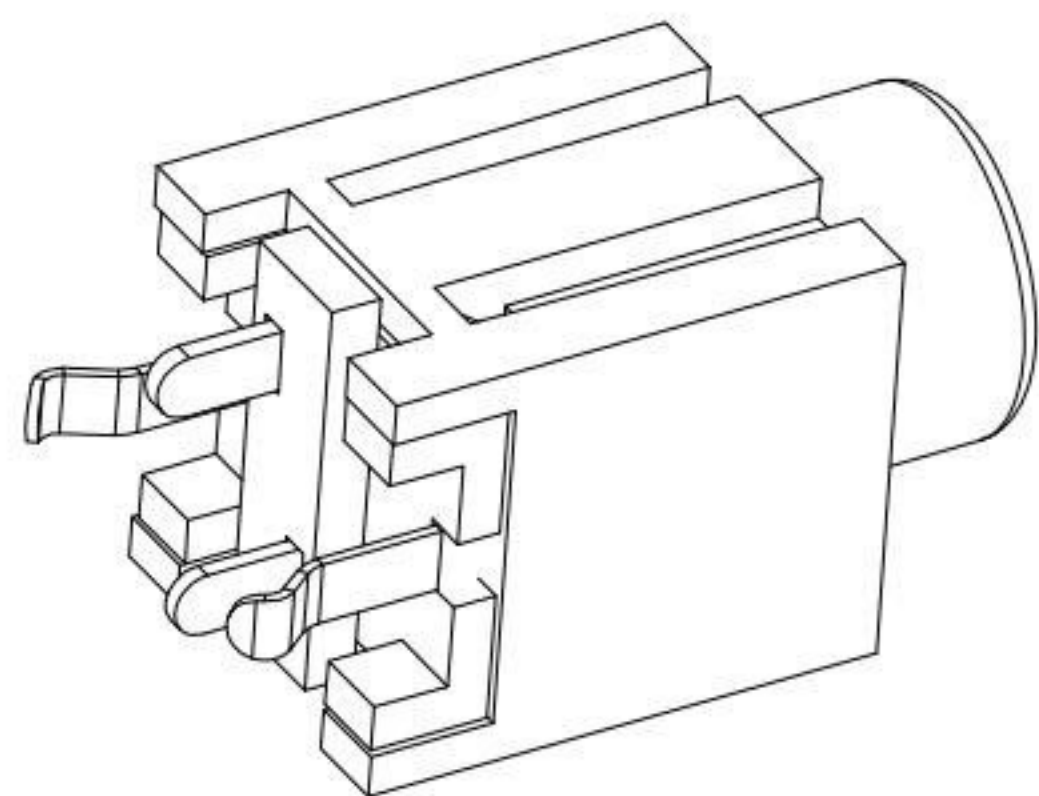
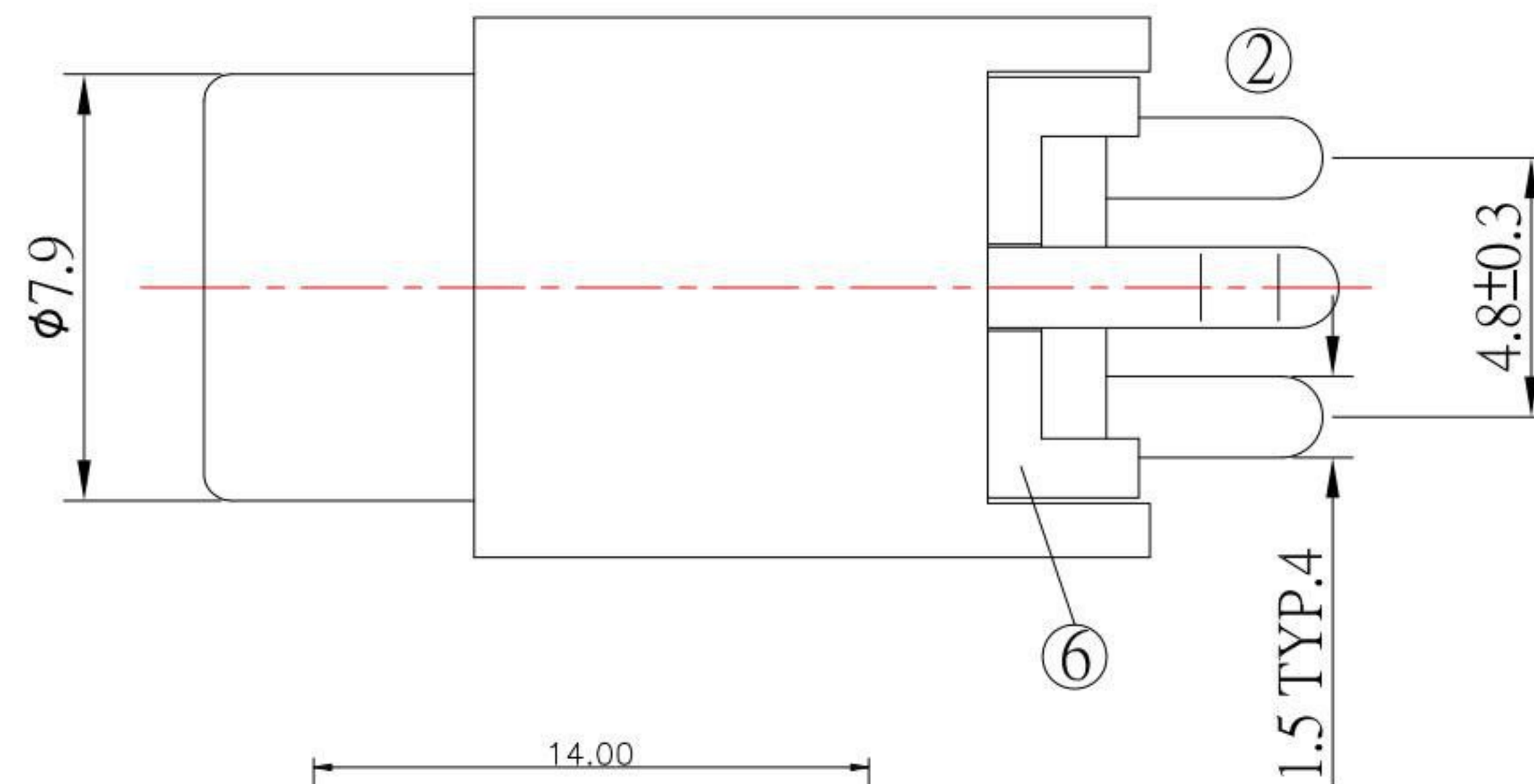

Ø3.50mm 3 POLE PLUG

SPECIFICATION

- 1.Rating : DC 30V 0.5A ;
- 2.Contact resistance : ≤ 30mΩ ;
- 3.Insulation resistance : ≥ 100MΩ ;
- 4.Withstand voltage : 500VAC ;
- 5.Insertion and extraction force : 3-20N;
- 6.life test : 5,000 cycles °

NO.	DESCRIPTION	QTY	MATERIAL	PLATING
6	COVER	1	PBT	
5	HOUSING	1	PBT	
4	FLAT PIECE	1	BRASS	Ag-Plating
3	SPRING PIECE	1	PHOSPHOR BRONZE	Ag-Plating
2	FLAT PIECE	1	BRASS	Ag-Plating
1	CONTACT FOOT	1	PHOSPHOR BRONZE	Ag-Plating

**KSD** 科斯达电子科技有限公司  
SWITCH CONNECTOR KSD ELECTRONIC TECHNOLOGY Co., LTD  
全球 互联零组件制造企业

TOLERANCE UNLESS OTHERWISE STATED:  
 Up to 5 ±0.2  
 Above 5 ~ 15 ±0.3  
 Above 15 ~ 30 ±0.4  
 Above 30 ~ 50 ±0.5  
 Angle ±0.3°

3RD. ANGEL'S

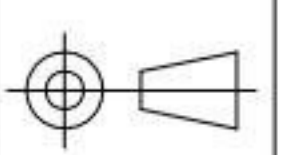

UNITS MM

DRAWN BY:	DATE	MAT'L	TITLE	SWITCH
Jack Lu	06/06/17		MODLE	TACT SWITCH
CHECKED BY:	DATE	FINISH	DWG NO.	PJ-D3042-x-S124
Jacky Chen	06/06/17		PART NO.	PJ-D3042-x-S124
APPROVED BY:	DATE	SCALE	1:1	
Tony Kao	06/06/17	SHEET NO.	1 of 1	

ITEM NO.	DESCRIPTION	DRAWN	DATE
1	更新尺寸	Jack	060617

7

7

SIZE A4  
VER R1