

P.C.B LAYOUT
TOP VIEW

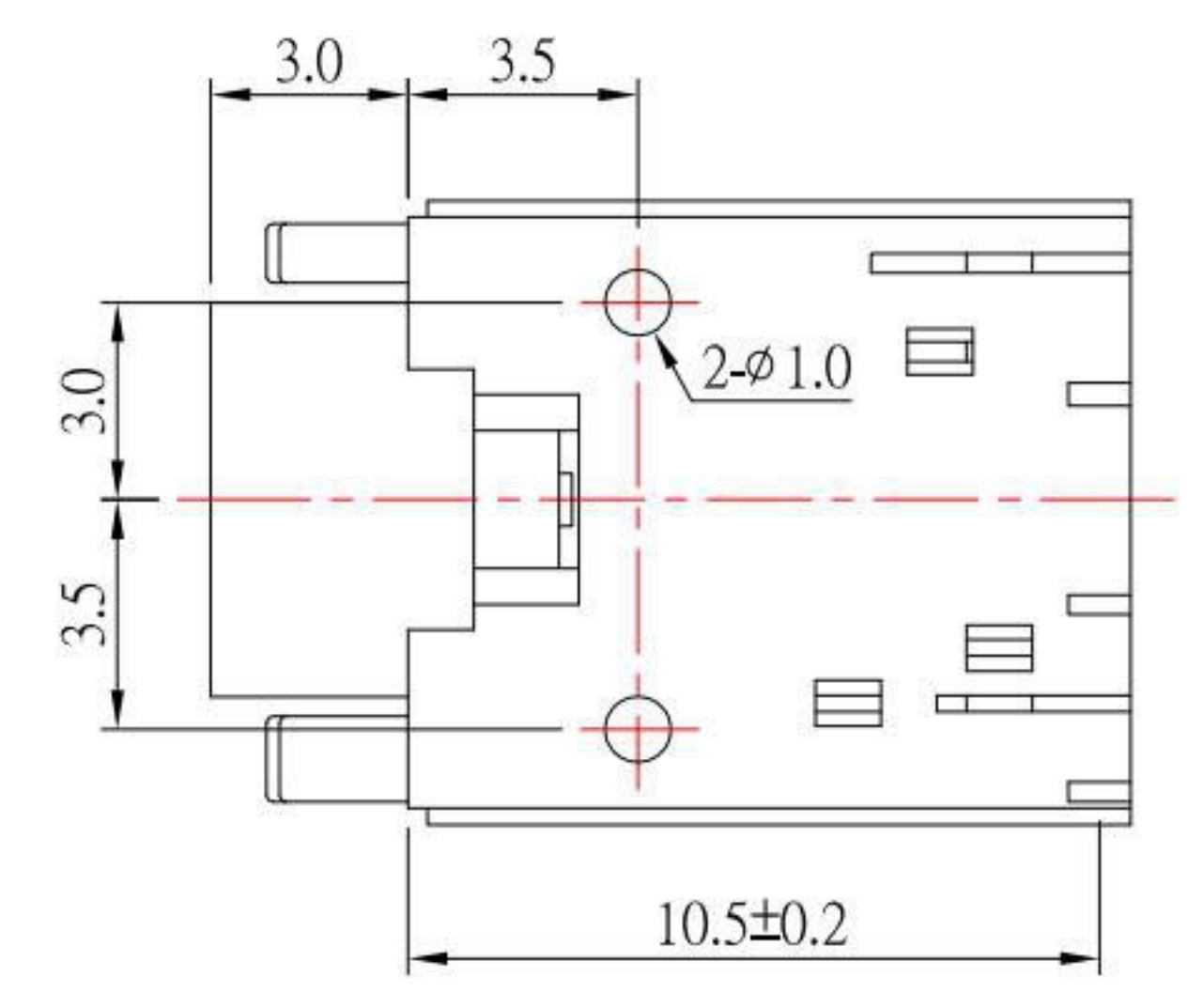

SCHEMATIC

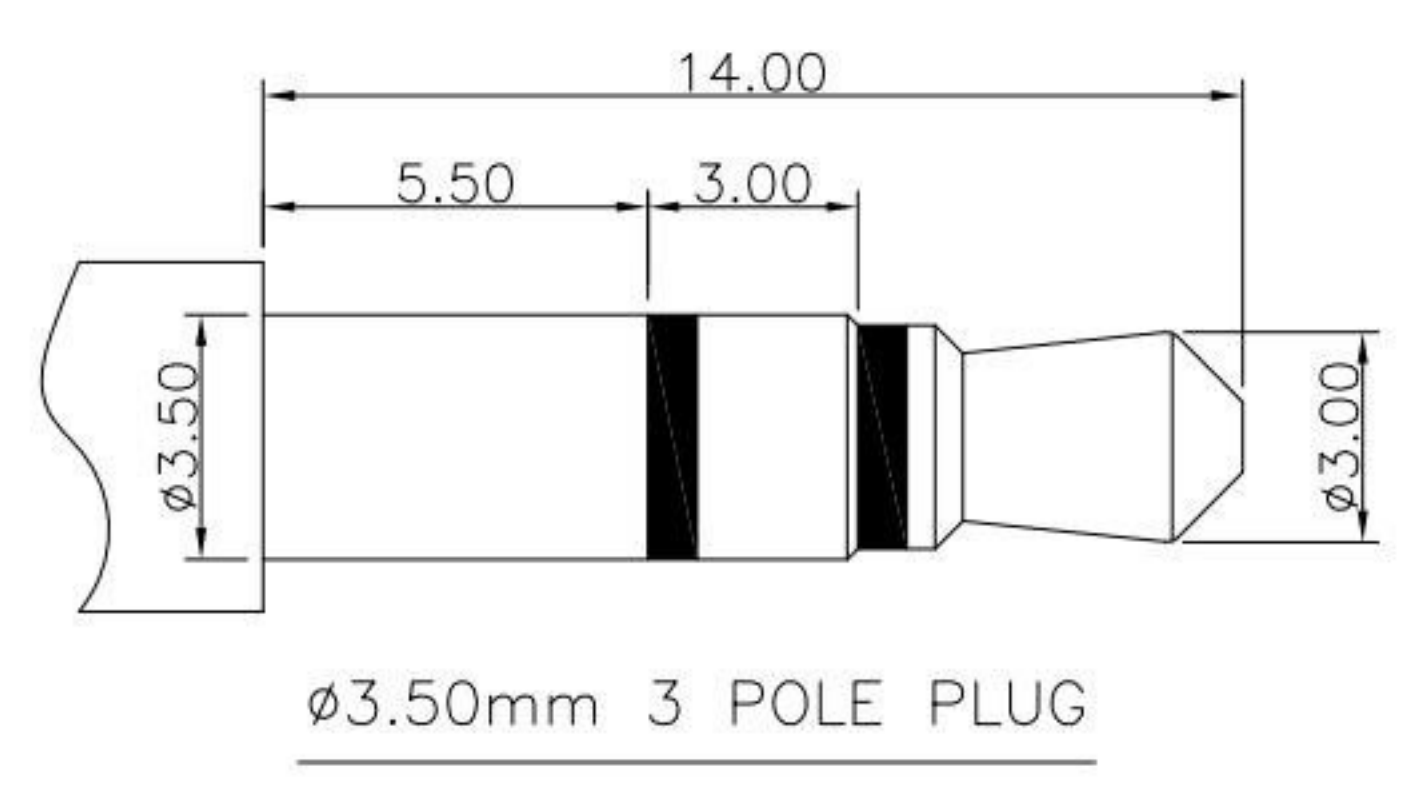
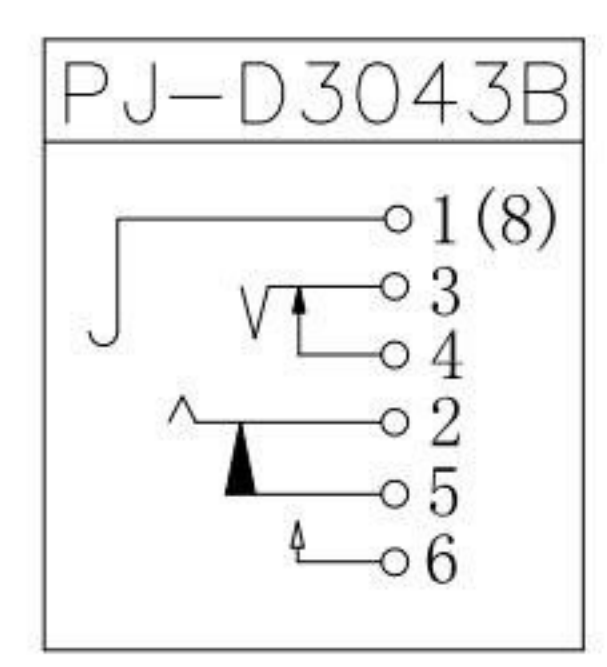

SPECIFICATION

1. Rating : DC 30V 0.5A ;
2. Contact resistance : $\leq 30m\Omega$;
3. Insulation resistance : $\geq 100M\Omega$;
4. Withstand voltage : 500VAC ;
5. Insertion and extraction force : 3-20N;
6. life test : 5,000 cycles °

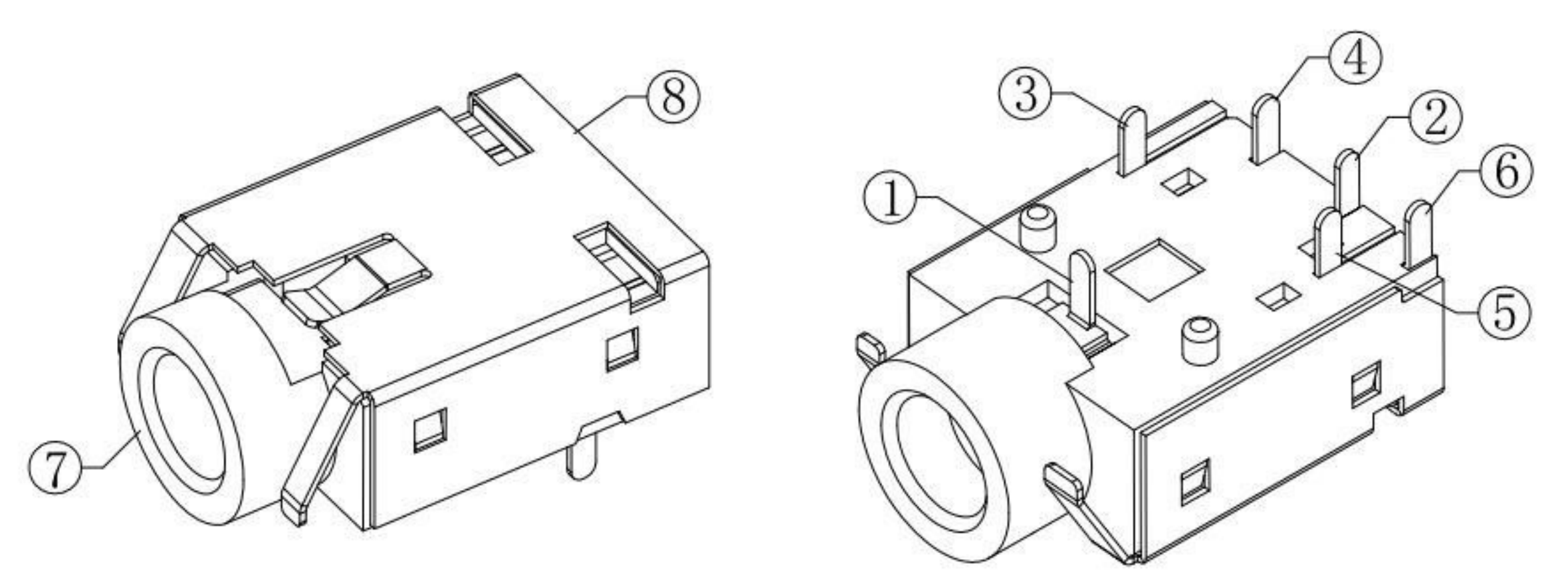

NO.	DESCRIPTION	QTY	MATERIAL	PLATING
⑧	COAT	1	PHOSPHOR BRONZE	Ni-Plating
⑦	HOUSING	1	PBT	
⑥	CONTACT FOOT	1	PHOSPHOR BRONZE	Ag-Plating
⑤	SPRING PIECE	1	SUS	Ag-Plating
④	CURVE PIECE	1	BRASS	Ag-Plating
③	SPRING PIECE	1	PHOSPHOR BRONZE	Ag-Plating
②	SPRING PIECE	1	SUS	Ag-Plating
①	CONTACT FOOT	1	PHOSPHOR BRONZE	Ag-Plating

KSD 科斯达电子科技有限公司
 SWITCH CONNECTOR KSD ELECTRONIC TECHNOLOGY Co., LTD
 全球 互联网 零组件 制造企业

TOLERANCE UNLESS OTHERWISE STATED:	Up to 5 ±0.2	3RD. ANGEL'S	UNITS	MM
	Above 5 ~ 15 ±0.3			
	Above 15 ~ 30 ±0.4			
	Above 30 ~ 50 ±0.5			
	Angle ±0.3°			

DRAWN BY:	DATE	MAT'L	TITLE	JACK
Jack Lu	06/18/19			
CHECKED BY:	DATE	FINISH	MODLE	PHONE JACK
Jacky Chen	06/18/19			
APPROVED BY:	DATE	SCALE	DWG NO.	PJ-D3043B-S124
Tony Kao	06/18/19	1:1		
		SHEET NO.	PART NO.	PJ-D3043B-S124
		1 of 1		

ITEM NO.	DESCRIPTION	DRAWN	DATE