

P.C.B LAYOUT
TOP VIEW

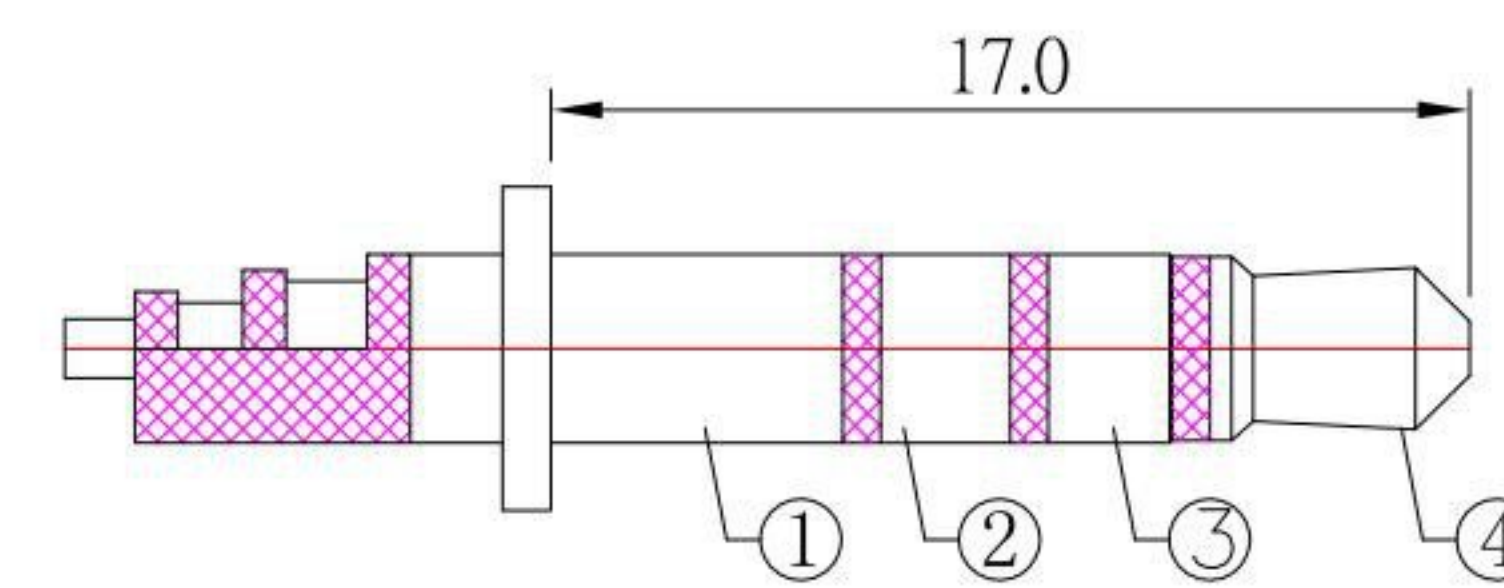

SCHEMATIC

PJ-S3013E-S125

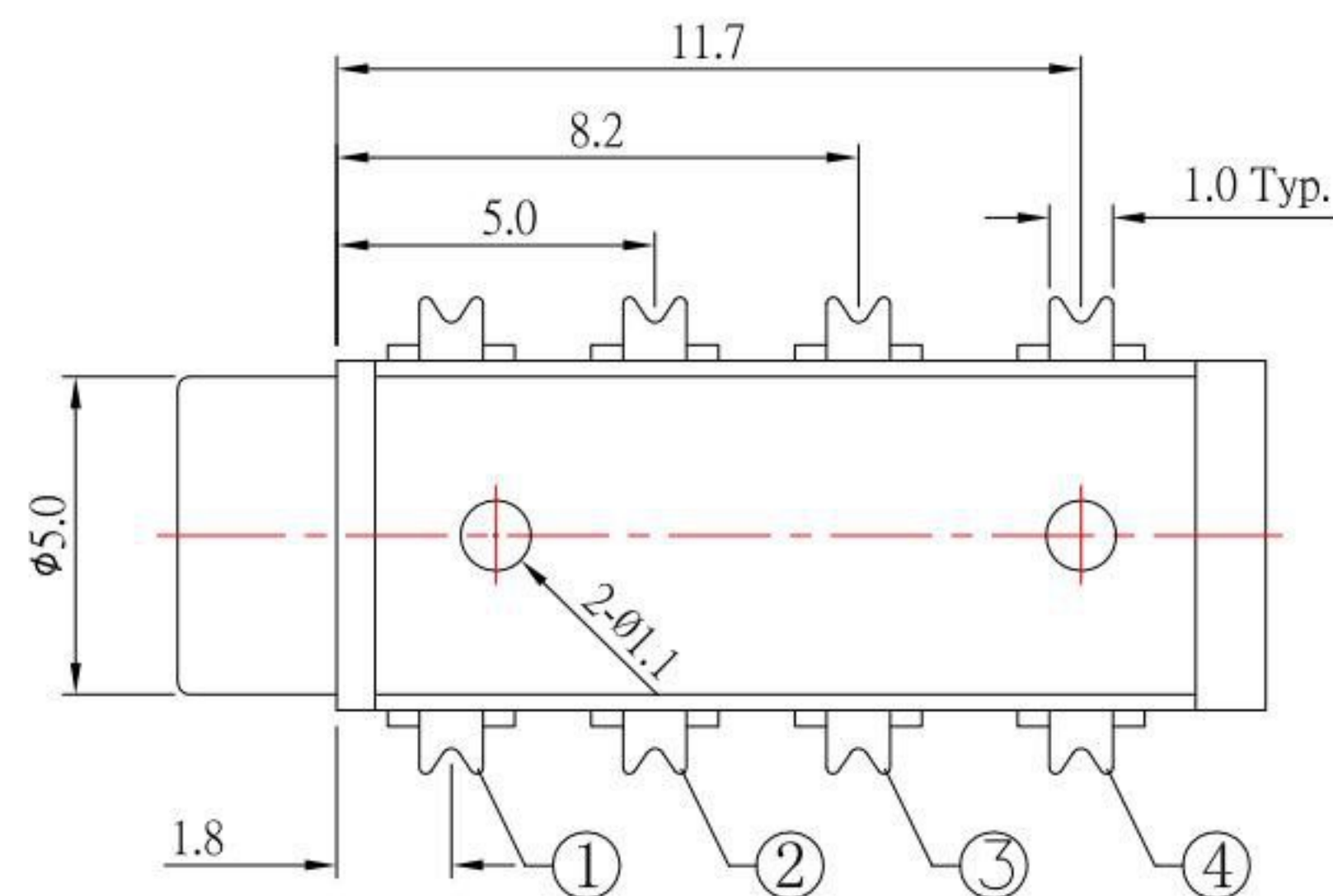
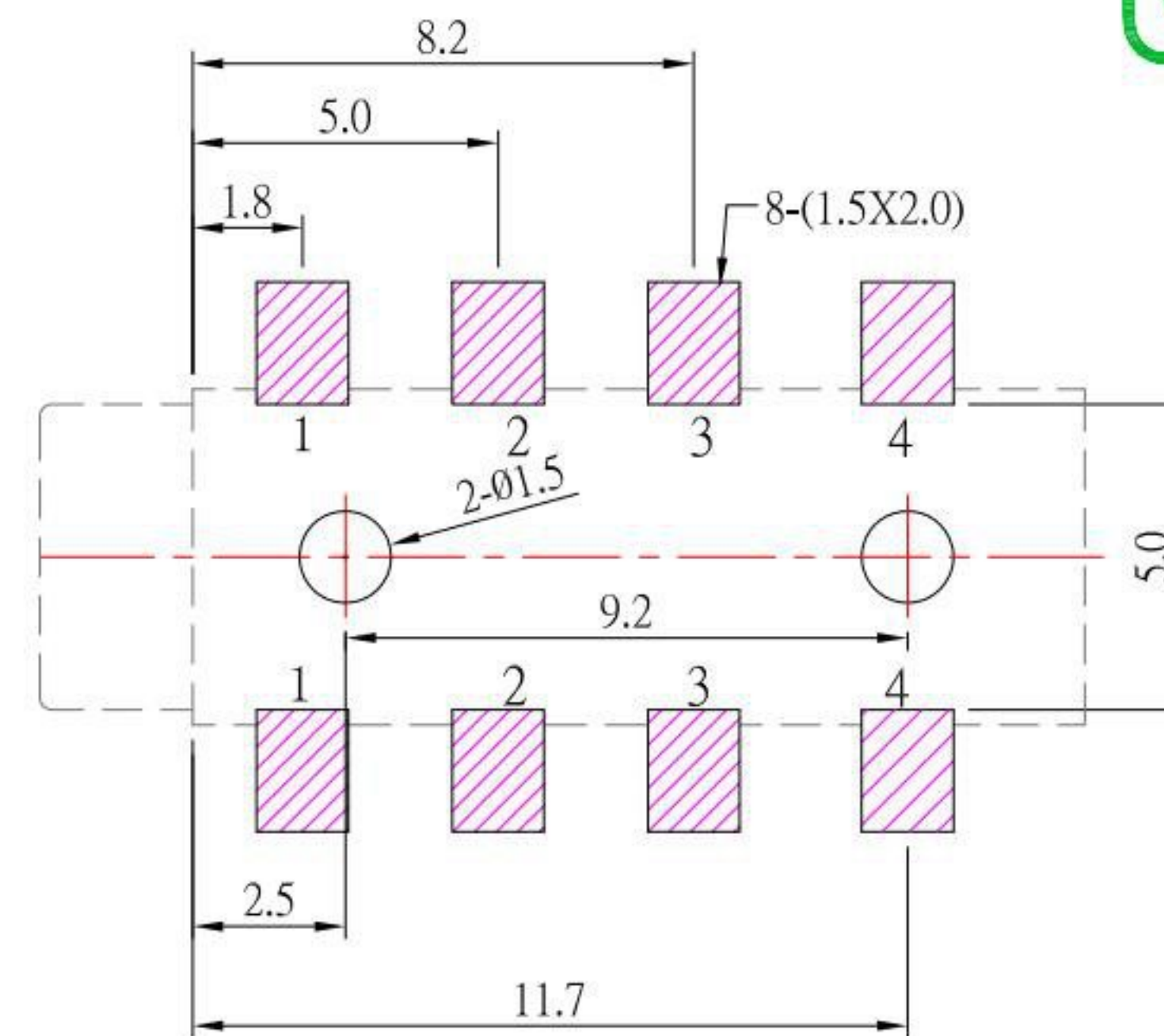
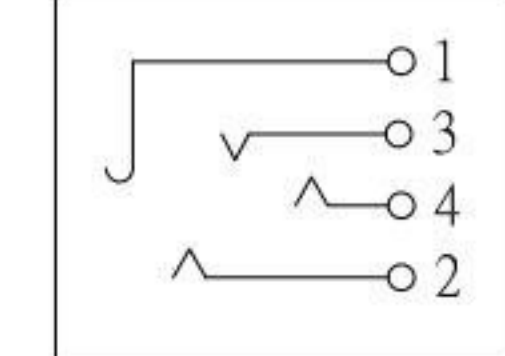

SPECIFICATION

1. Rating : DC 30V 0.5A
2. Contact resistance : $\leq 50m\Omega$
3. Insulation resistance : $\geq 100M\Omega$ (DC250V)
4. Withstand voltage : 500VAC
5. Insertion and extraction force : 3-20N
6. life test : 5,000 cycles

NO.	DESCRIPTION	QTY	MATERIAL	PLATING
⑤	HOUSING	1	PA9T	
④	CONTACT FOOT #4	1	STAINLESS STEEL	Ag-Plating
③	CONTACT FOOT #3	1	STAINLESS STEEL	Ag-Plating
②	CONTACT FOOT #2	1	STAINLESS STEEL	Ag-Plating
①	CONTACT FOOT #1	1	STAINLESS STEEL	Ag-Plating

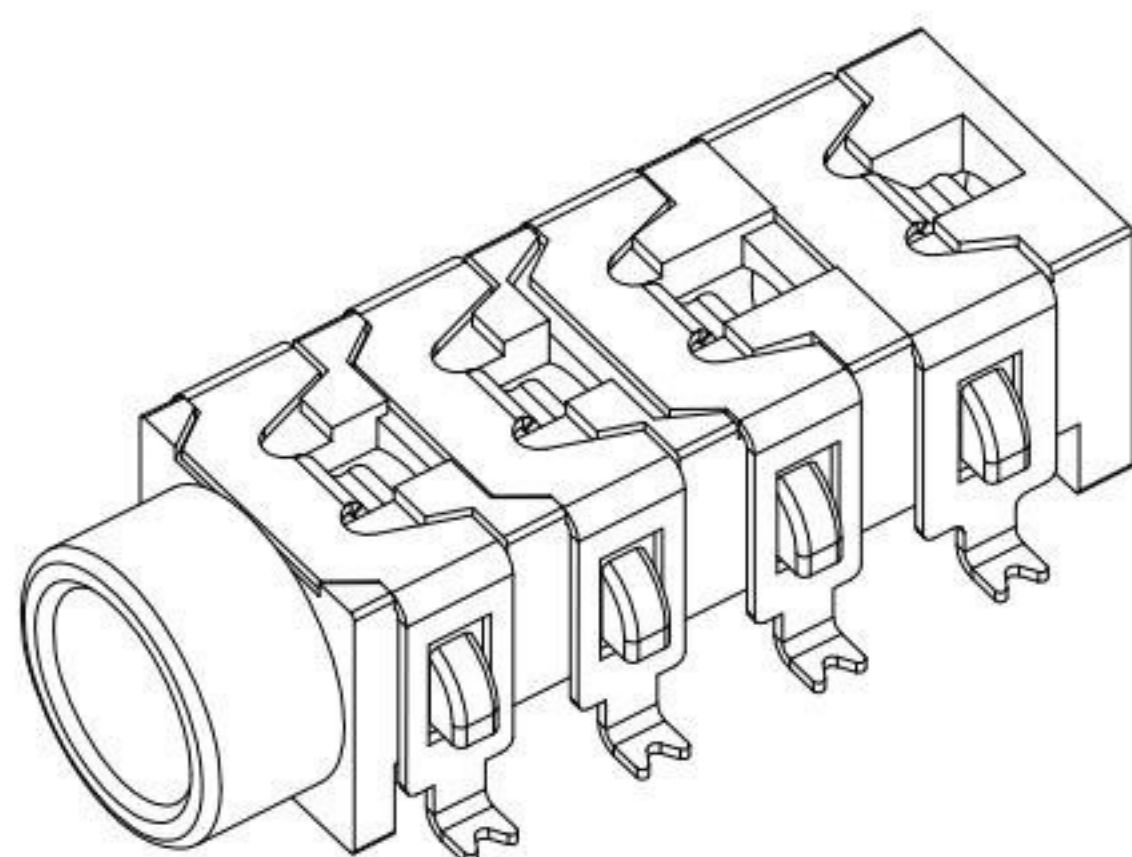
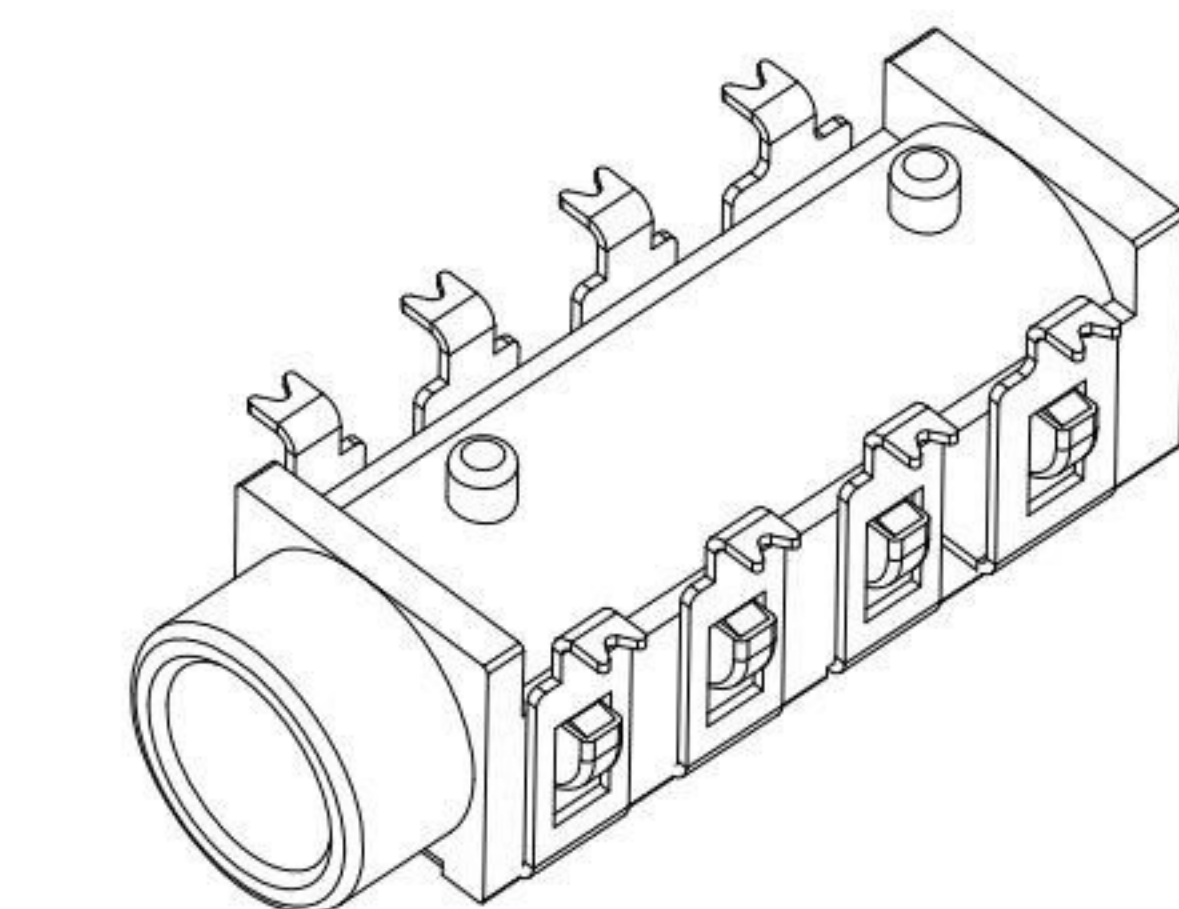

KSD 科斯达电子科技有限公司
SWITCH CONNECTOR 全球 互联零组件制造企业
KSD ELECTRONIC TECHNOLOGY Co., LTD

TOLERANCE UNLESS OTHERWISE STATED :
Up to 5 ± 0.2
Above 5 ~ 15 ± 0.3
Above 15 ~ 30 ± 0.4
Above 30 ~ 50 ± 0.5
Angle $\pm 0.3^\circ$

3RD. ANGEL'S

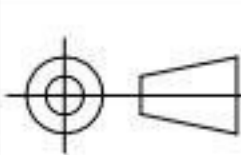

UNITS

MM

DRAWN BY: Jack Lu
DATE: 04/15/14
CHECKED BY: Jacky Chen
DATE: 04/15/14
APPROVED BY: Tony Kao
DATE: 04/15/14

MAT'L
FINISH
SCALE: 1:1
SHEET NO.: 1 of 1

TITLE: JACK
MODLE: PHONE JACK
DWG NO.: PJ-S3013E-S125
PART NO.: PJ-S3013E-S125

SIZE: A4
VER: R2

ITEM NO.	DESCRIPTION	DRAWN	DATE
2	更新SPEC及材質	Jack	041514
1	更新圖面	Jack	112312