

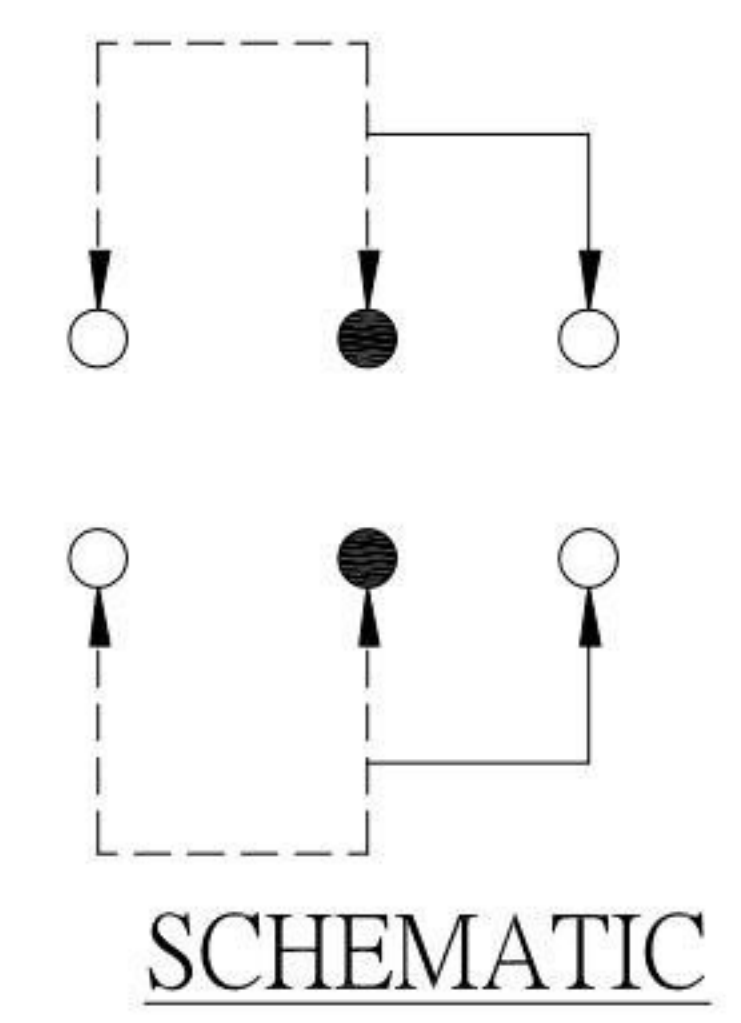

DIMNSIONS

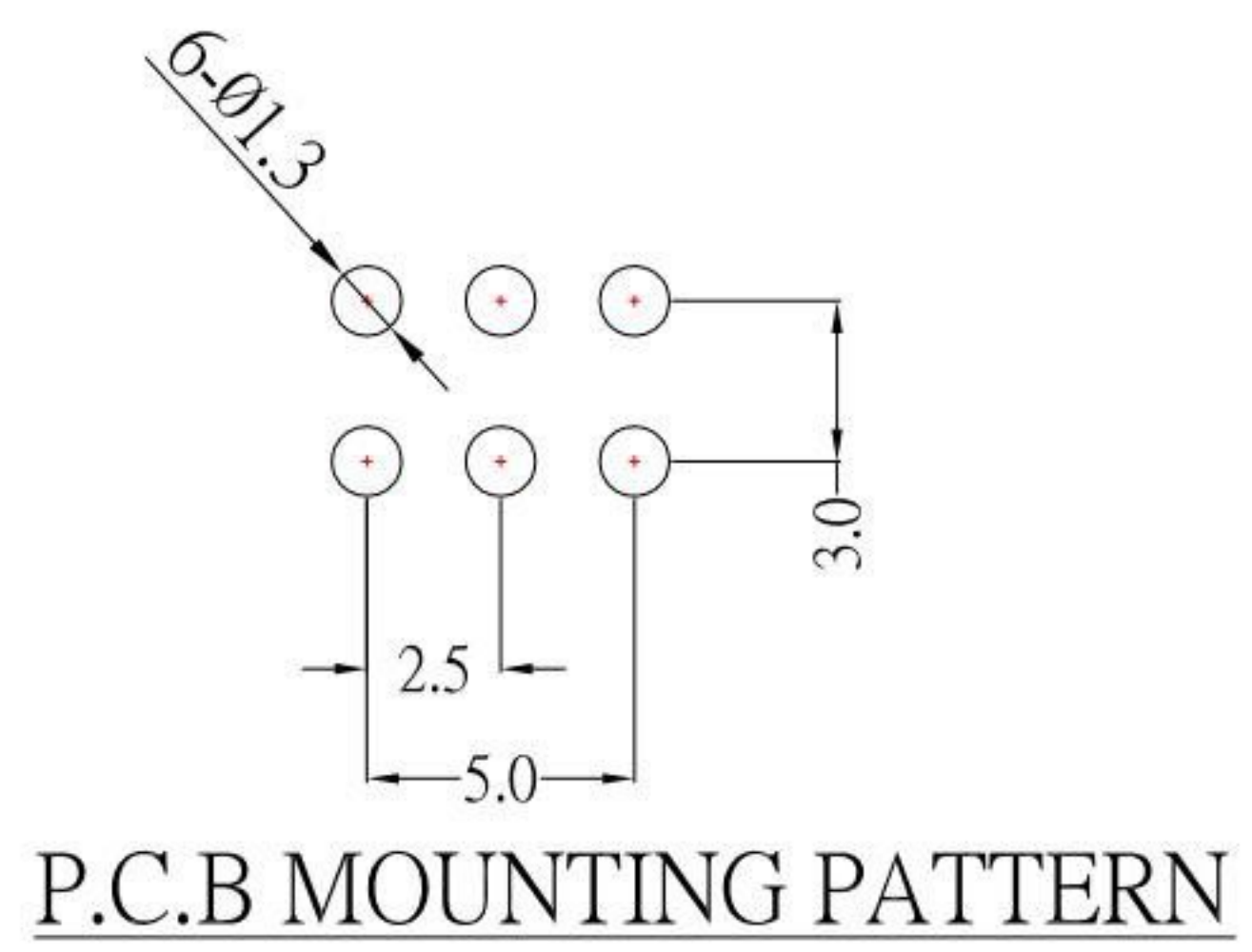

3.5 TRAVEL(2.5LOCK)

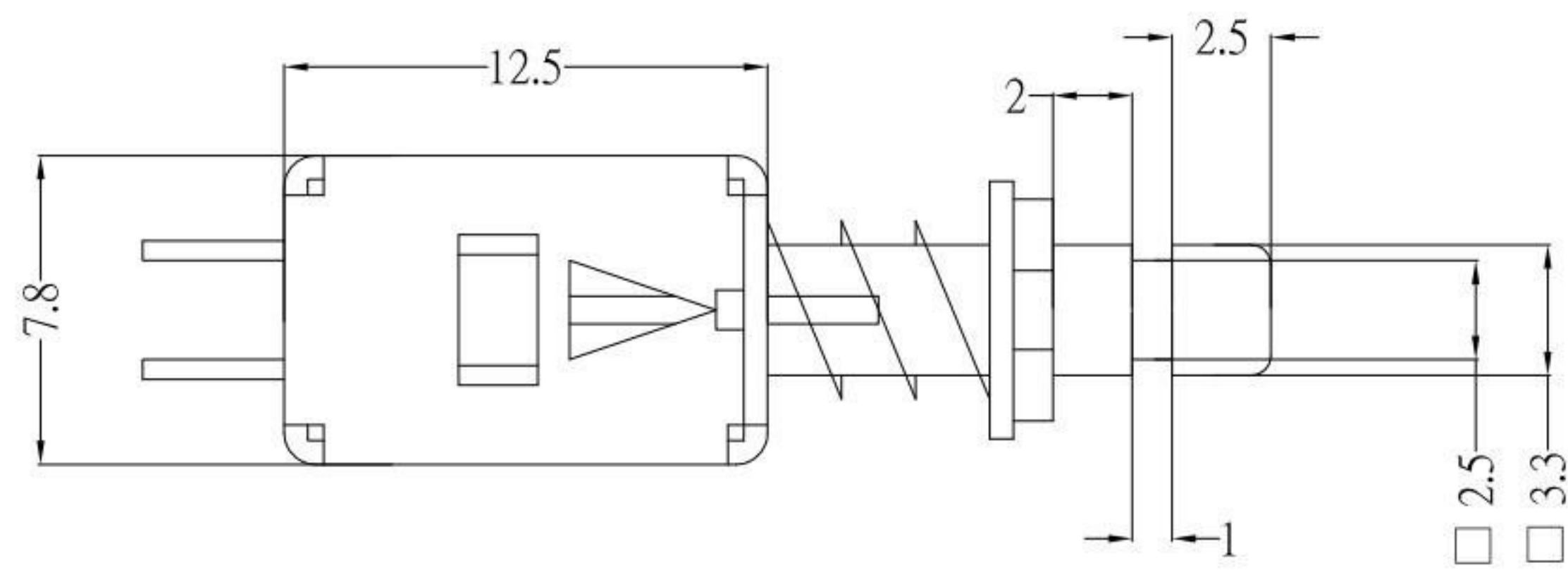
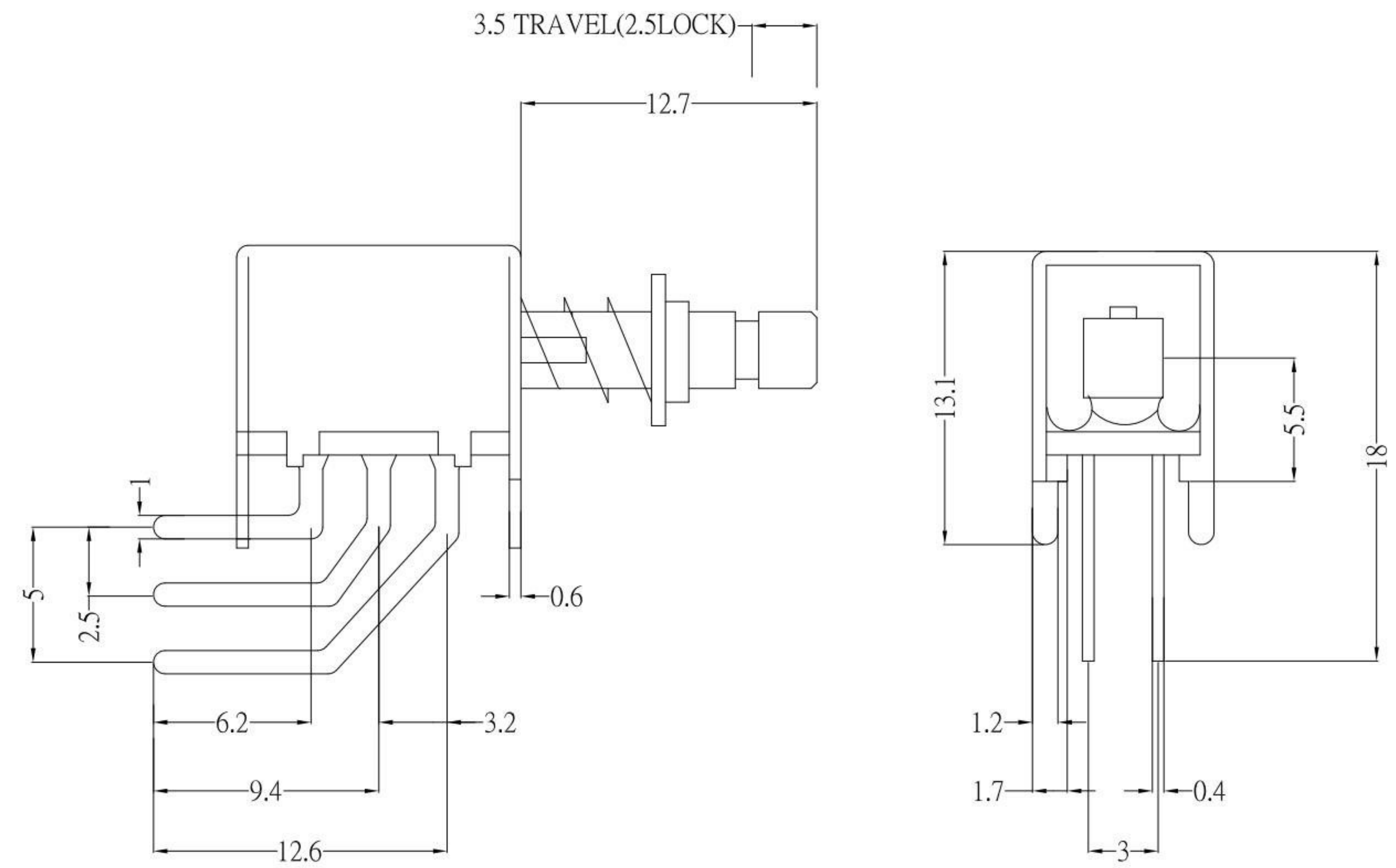

SPECIFICATIONS

Rating	DC50V 0.3A
Contact Resistance	70 mΩ Max
Circuit	2P2T
Timing	Non-Shorting
Operating force	350 ± 100gf
Life test	10,000 cycles

NO.	DESCRIPTION	QTY	MATERIAL	REMARK
9	CONTACT CLIP	2	BRASS	Ag-Plated
8	SHRAPNEL	2	BRASS	
7	HOOK	2	BRASS	
6	BLOCK	1	STEEL	Ni-Plated
5	SPRING	1	STEEL	Ni-Plated
4	TERMINAL	6	BRASS	Ag-plated over Ni plated
3	BASE	1	PHENOLIC RESIN	Natural
2	FRAME	1	STEEL	Ni-Plated
1	KNOB	1	POM	Black

KSD 科斯达电子科技有限公司
 SWITCH CONNECTOR KSD ELECTRONIC TECHNOLOGY Co., LTD
 全球 互联零组件制造企业

TOLERANCE UNLESS OTHERWISE STATED :
 Up to 5 ±0.2
 Above 5 ~ 30 ±0.3
 Above 30 ~ 50 ±0.4
 Above 50 ±0.5
 Angle ±0.3°

3RD. ANGEL'S

UNITS MM

DRAWN BY:	DATE	MAT'L	TITLE	SWITCH
Jack Lu	12/28/15		MODLE	PUSH SWITCH
CHECKED BY:	DATE	SCALE	DWG NO.	PS-22F35L-S191
Jacky Chen	12/28/15	1 : 1	PART NO.	PS-22F35L-S191
APPROVED BY:	DATE	SHEET NO.		
Tony Kao	12/28/15	1 of 1		

ITEM NO.	DESCRIPTION	DRAWN	DATE
1	新增SPEC	Jack	122815