

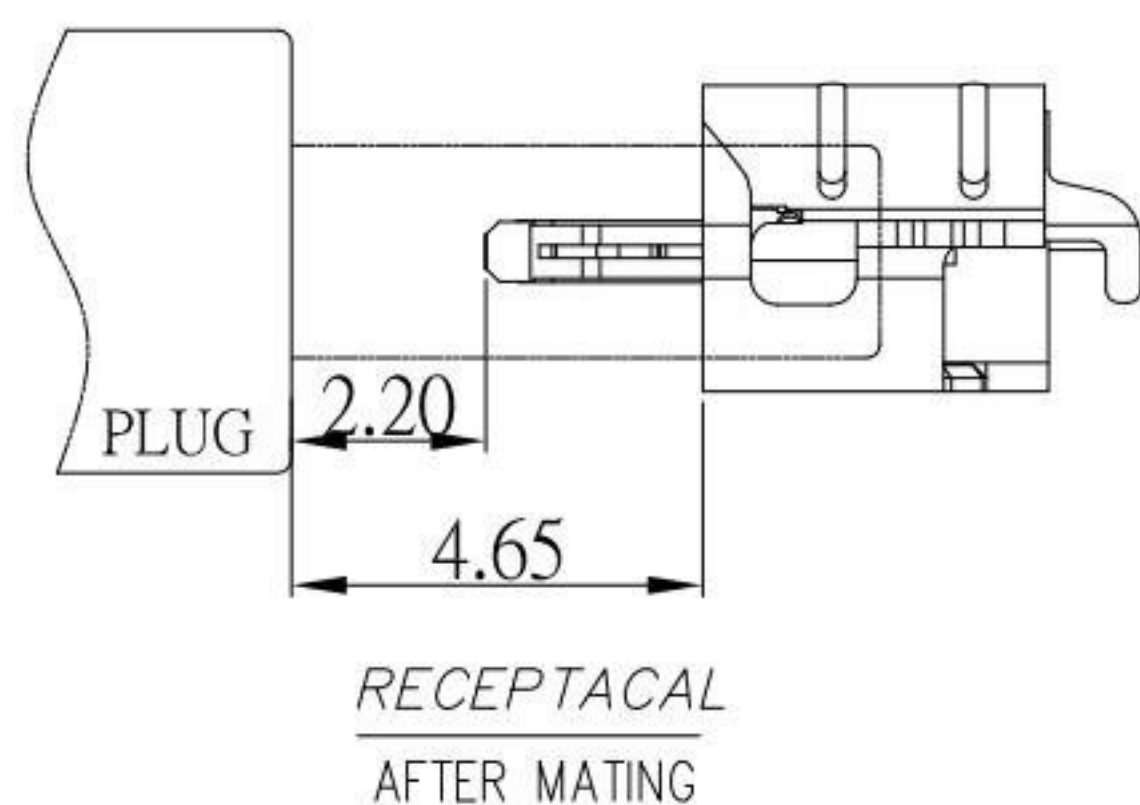

SBC-160M19H-20x-S331

鍍層厚度:

Blank	: 1u"
2	: 15u"
3	: 30u"

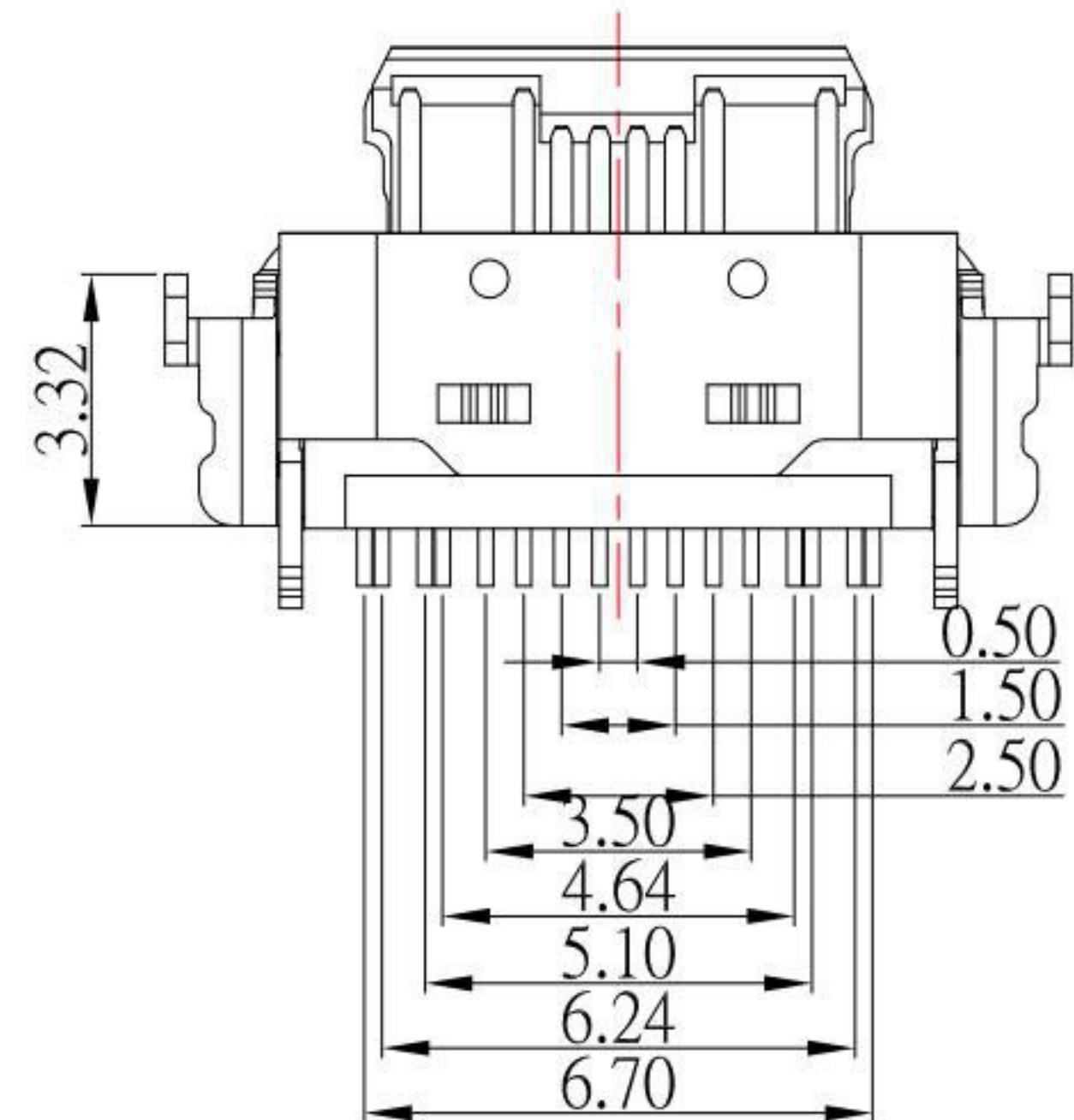
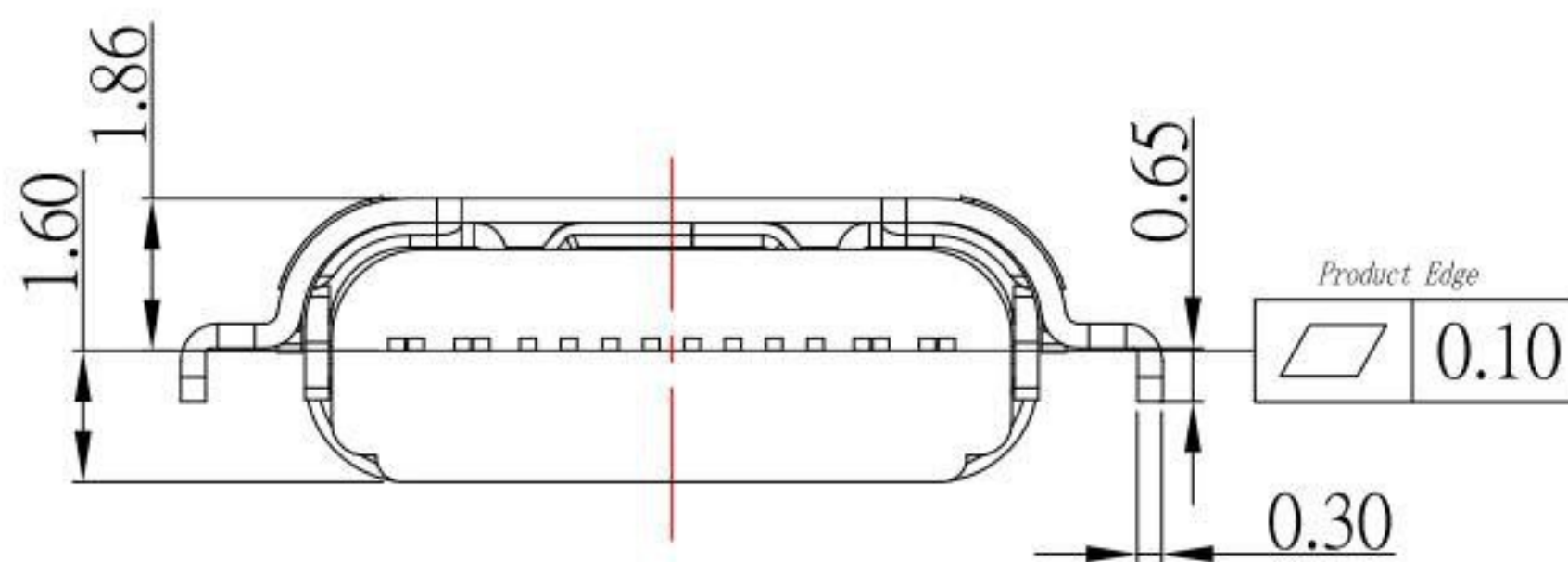
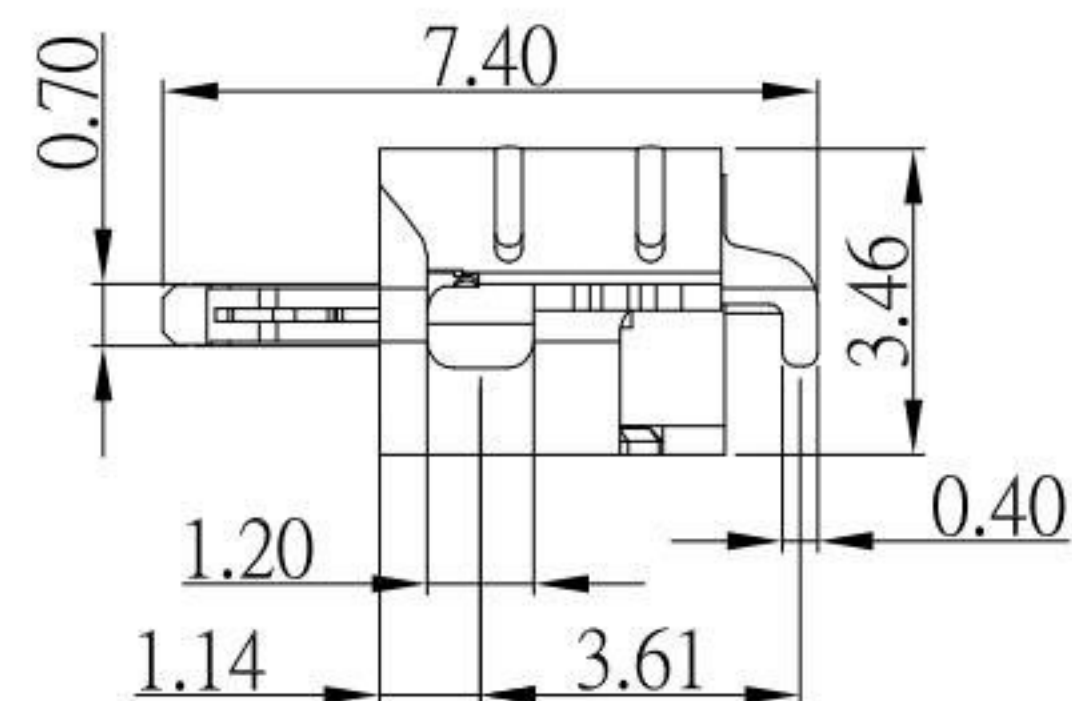
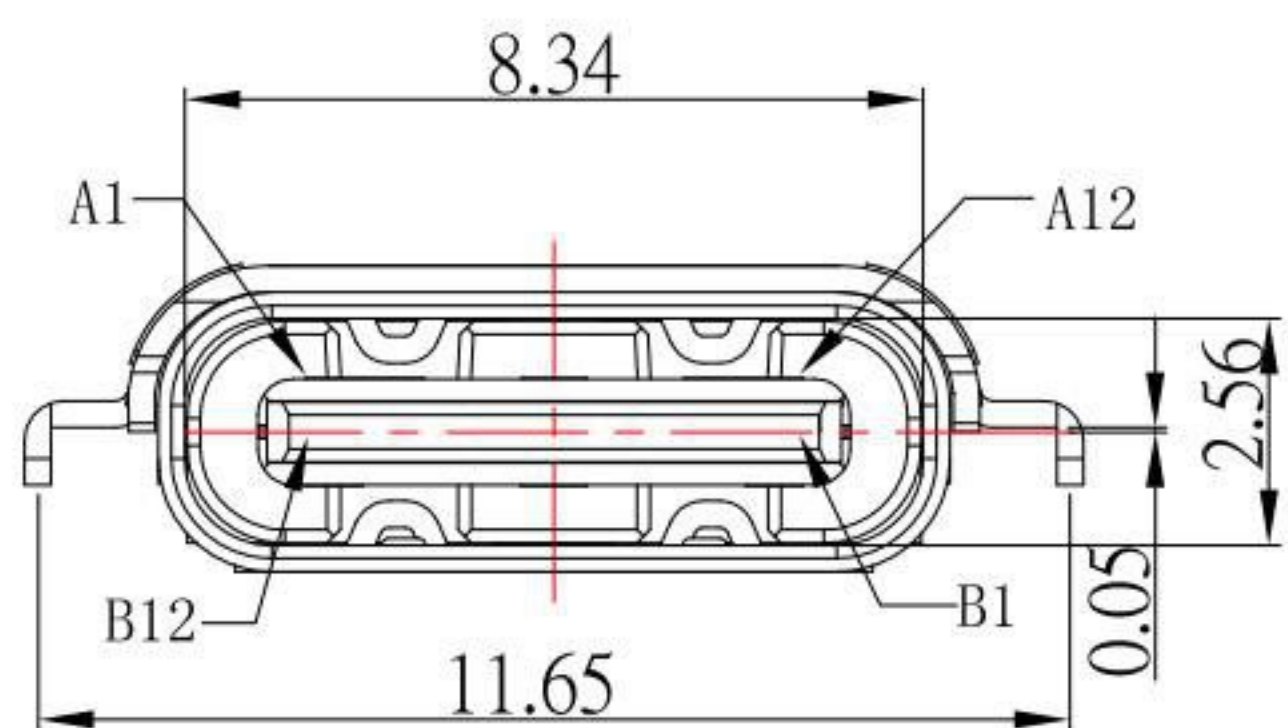
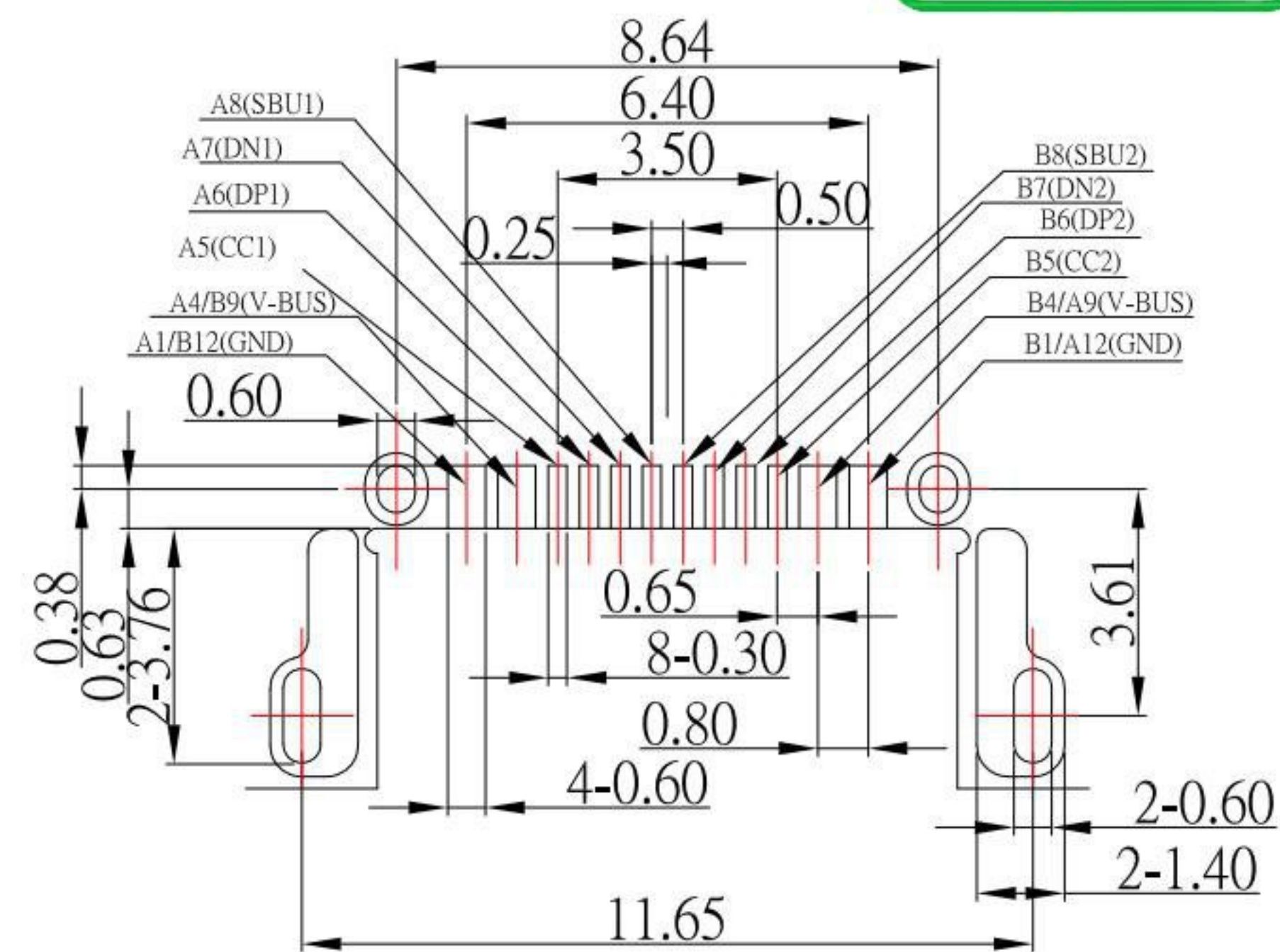
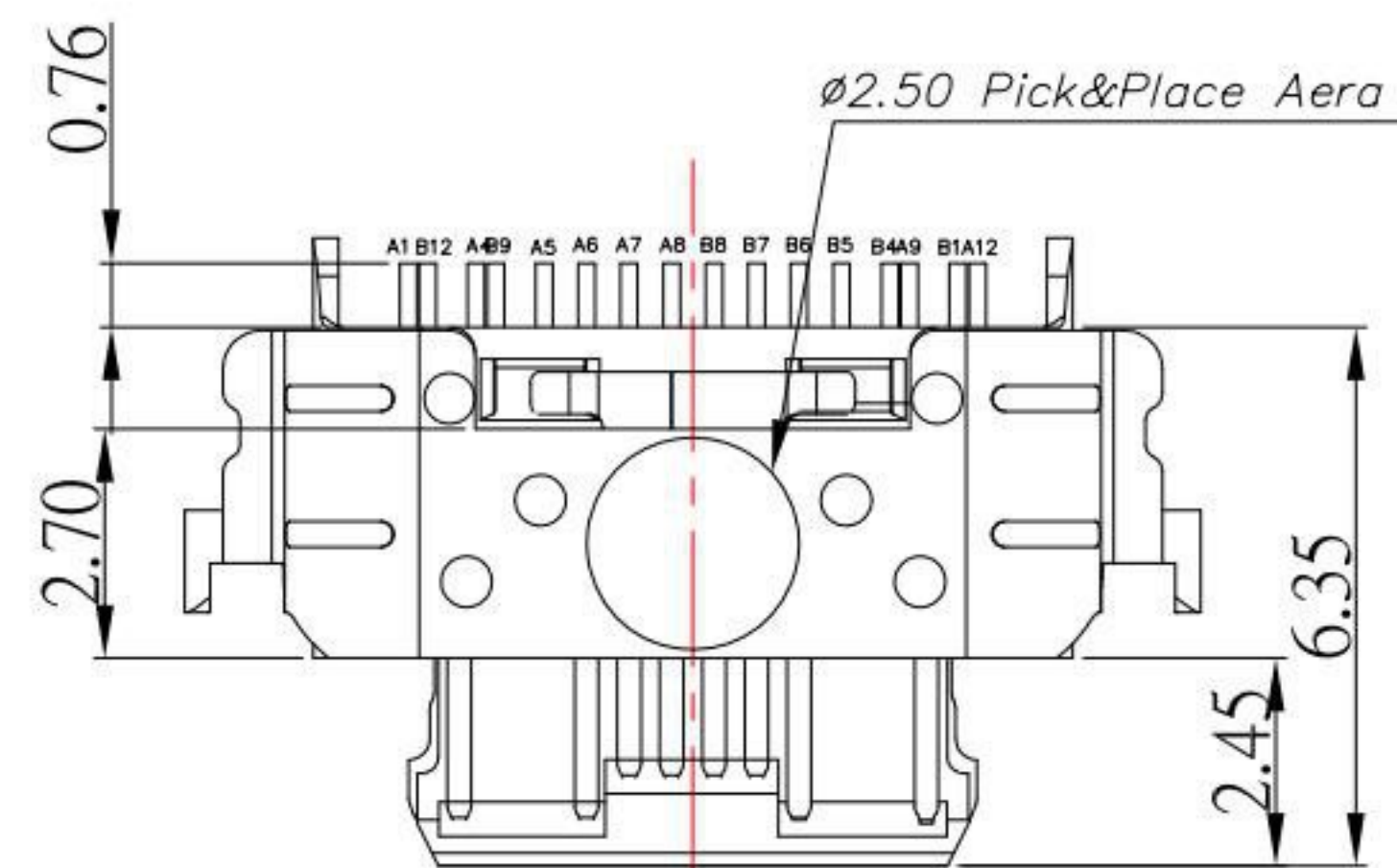

SPECIFICATIONS

Electrical:

1. Rating: 5.0 V, 5.0 A
2. Dielectric Withstand Voltage: 100V AC
3. Contact Resistance: 40 mΩ Max
4. Insulation Resistance: 100 MΩ Min

Mechanical:

1. Connector Mate and Unmate Force
 - 1.1 Mate force: 5~20 N
 - 1.2 Unmate force: 8~20 N

Material:

1. Housing: LCP
2. Contact: C18150
3. Shell: SUS

Finish:

1. Contact: Plated Gold in Mating Area ;
Gold Plated on Solder Balls ;
Nickel under plated overall
2. Shell: Nickel under Plated surface layer

KSD 科斯达电子科技有限公司
SWITCH CONNECTOR KSD ELECTRONIC TECHNOLOGY Co., LTD
全球 互聯零組件製造企業

TOLERANCE UNLESS OTHERWISE STATED:
Up to 5 ±0.2
Above 5 ~ 15 ±0.3
Above 15 ~ 30 ±0.4
Above 30 ~ 50 ±0.5
Angle ±0.3°

3RD. ANGEL'S

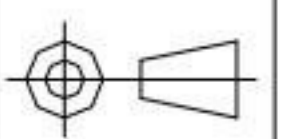

UNITS MM

DRAWN BY:	DATE	MAT'L	TITLE	CONNECTOR
Jack Lu	03/08/23		MODLE	USB TYPE C 2.0 沉板板上 H1.86mm高導電銅
CHECKED BY:	DATE	FINISH	DWG NO.	SBC-160M19H-20x-S331
Jacky Chen	03/08/23		PART NO.	SBC-160M19H-20x-S331
APPROVED BY:	DATE	SCALE	SHEET NO.	1 of 1
Tony Kao	03/08/23	1 : 1		

ITEM NO.	DESCRIPTION	DRAWN	DATE