

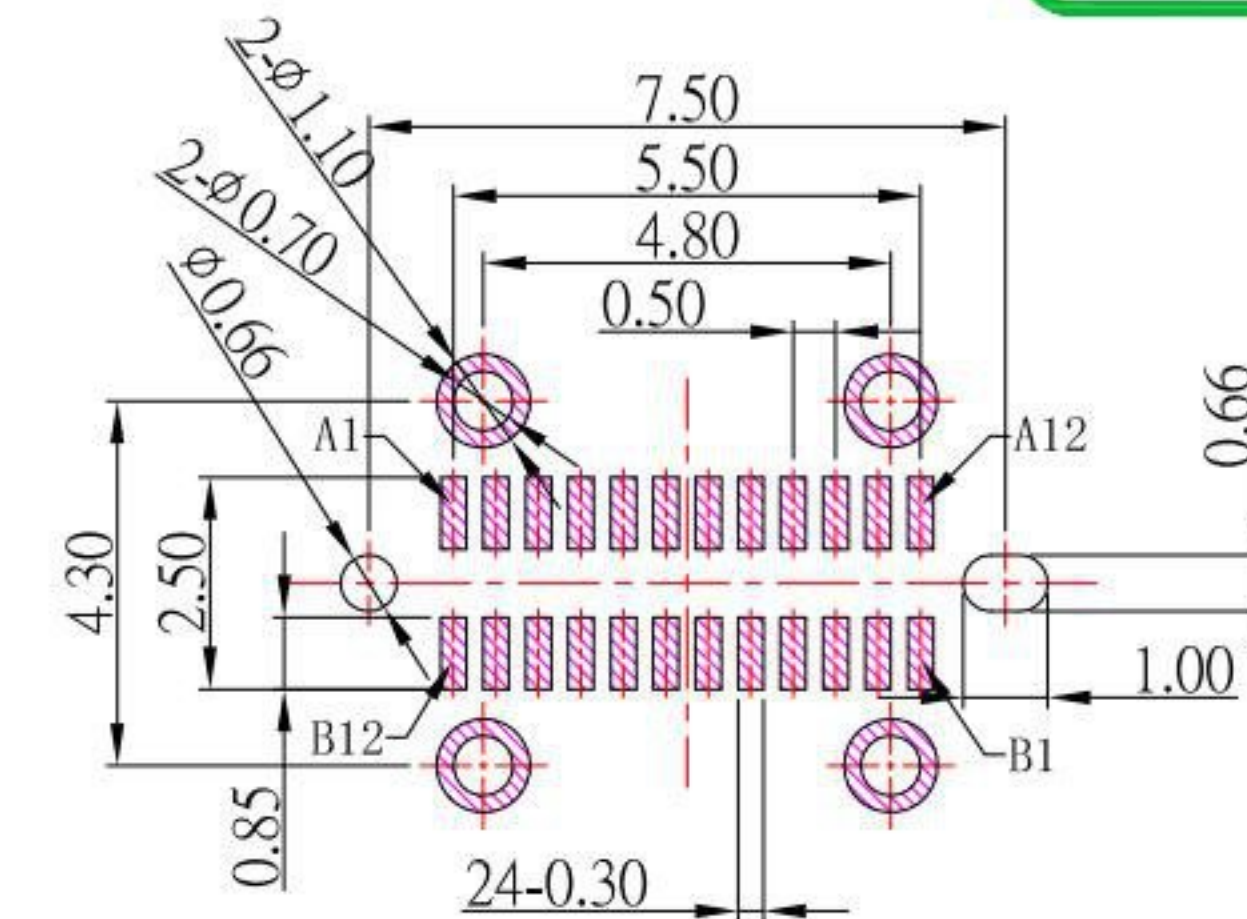

SBC-240VSE2C31x-S175

鍍層厚度:

Blank : 1u"
2 : 15u"
3 : 30u"



RECOMMENDED P.C.B. LAYOUT

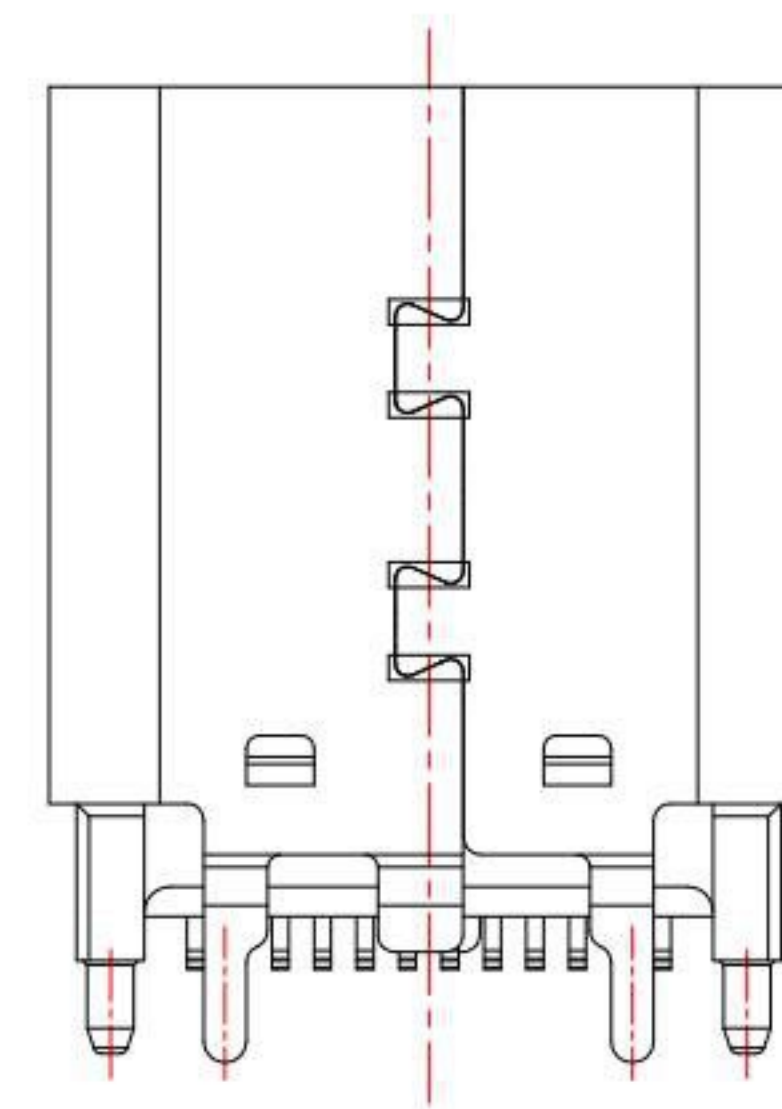
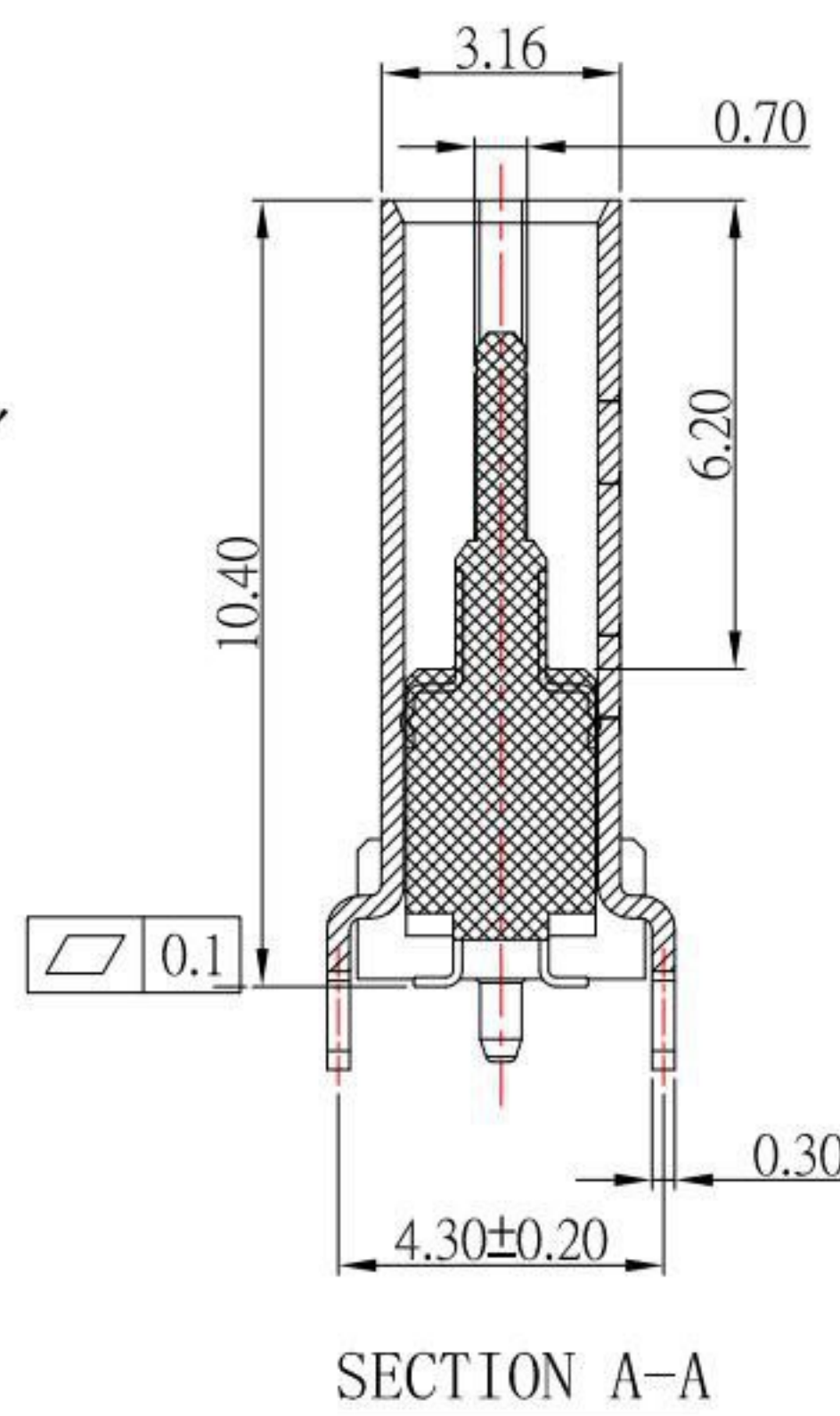
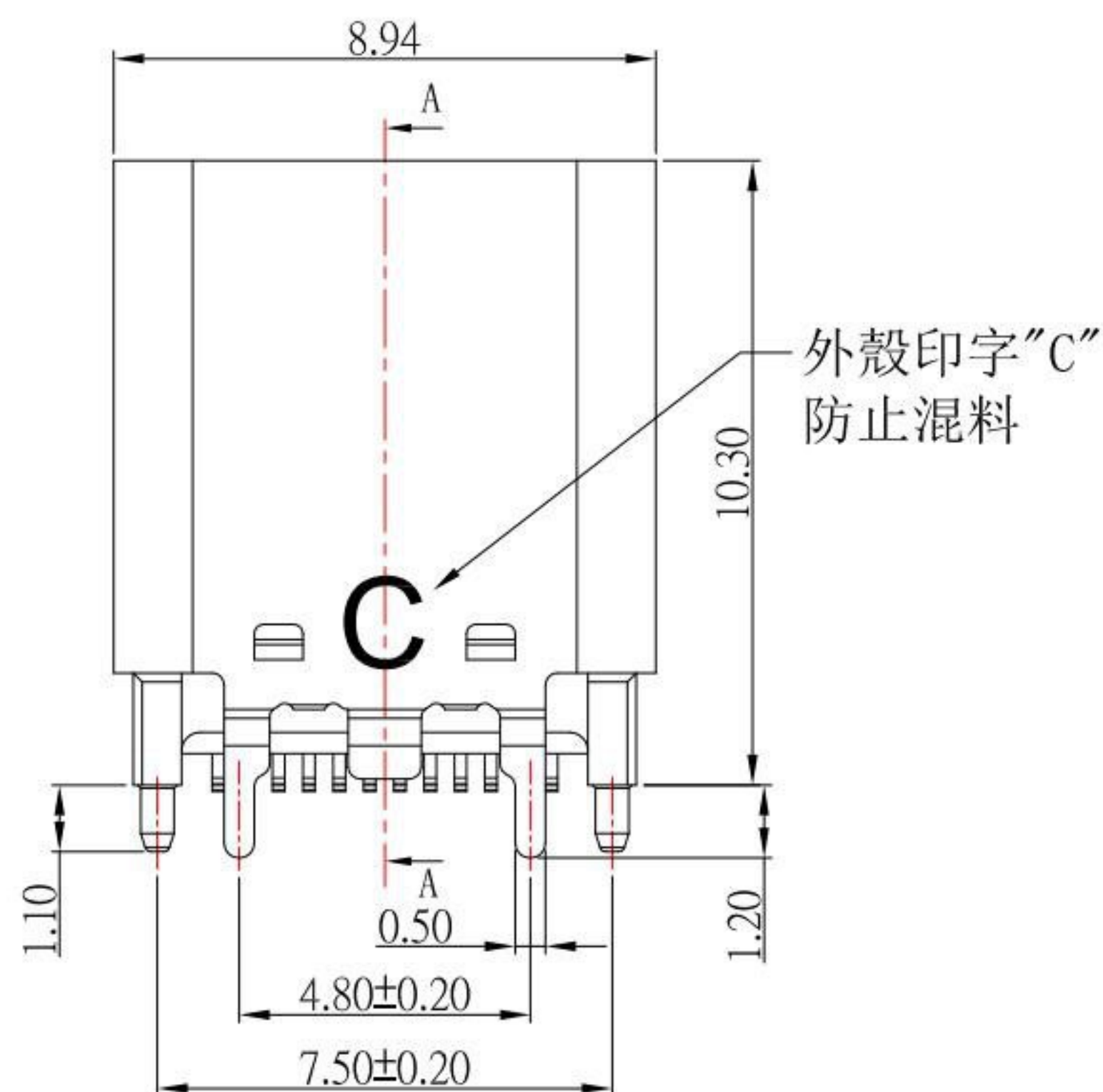
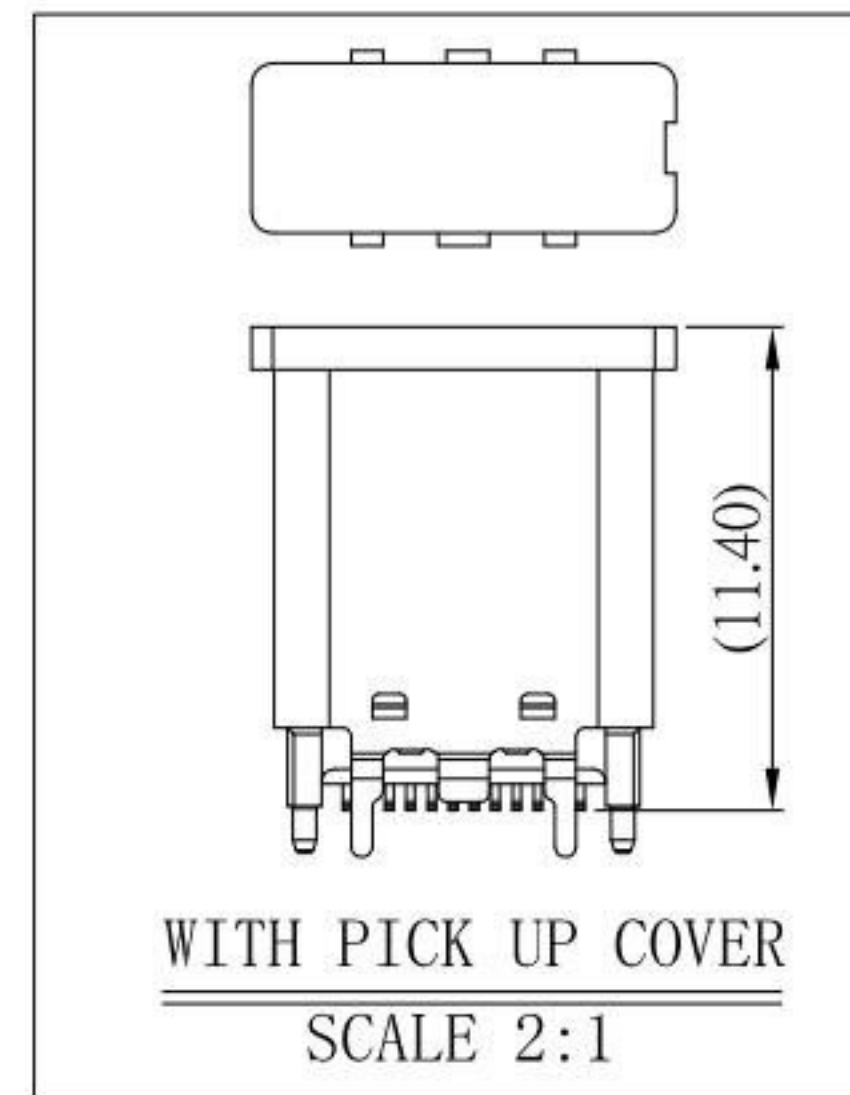
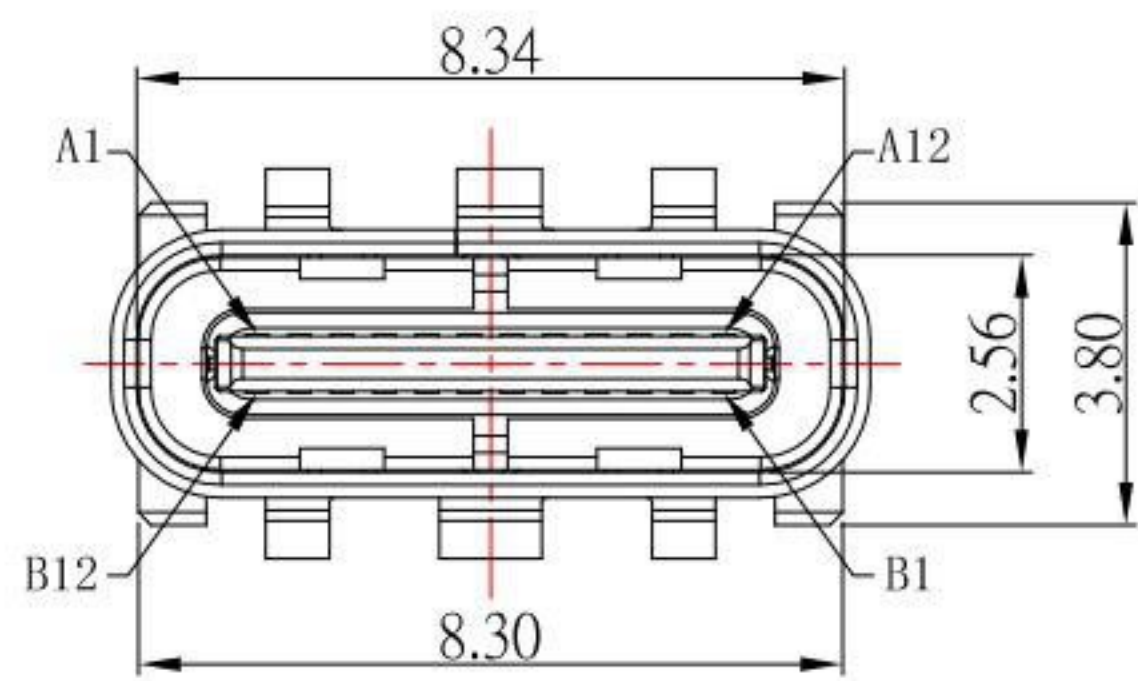

SPECIFICATIONS

Electrical:

- 1.Rating: 5.0 A , 5.0V
- 2.Dielectric Withstand Voltage: 100V AC
- 3.Contact Resistance: 40 mΩ Max
- 4.Insulation Resistance: 100 MΩ Min

Mechanical:

- 1.Connector Mate and Unmate Force
 - 1.1 Mate force: 5~20 N
 - 1.2 Unmate force: 8~20 N

Material:

- 1.Housing: LCP
- 2.Contact: C18400
- 3.Shell: SUS

Finish:

- 1.Contact: Plated Gold in Mating Area ;
Tin Plated on Solder Balls ;
Nickel under plated overall
- 2.Shell: Nickel under Plated surface layer

USB TYPE C PIN ASSIGNMENTS

PIN NUMBER	SIGNAL NAME	PIN NUMBER	SIGNAL NAME
A1	GND	B12	GND
A2	TX1+	B11	TX1+
A3	TX1-	B10	TX1-
A4	VBUS	B9	VBUS
A5	CC1	B8	SBU2
A6	DP1	B7	DN2
A7	DN1	B6	DP2
A8	SBU1	B5	CC2
A9	VBUS	B4	VBUS
A10	RX2-	B3	TX2-
A11	RX2+	B2	TX2+
A12	GND	B1	GND

KSD 科斯达电子科技有限公司
SWITCH CONNECTOR KSD ELECTRONIC TECHNOLOGY Co., LTD
全球 互联零组件制造企业

TOLERANCE UNLESS OTHERWISE STATED:
Up to 5 ±0.2
Above 5 ~ 15 ±0.3
Above 15 ~ 30 ±0.4
Above 30 ~ 50 ±0.5
Angle ±0.3°

3RD. ANGEL'S

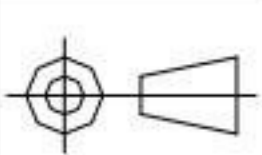

UNITS

MM

DRAWN BY: Jack Lu DATE: 05/10/22
CHECKED BY: Jacky Chen DATE: 05/10/22
APPROVED BY: Tony Kao DATE: 05/10/22

MAT'L
FINISH
SCALE 1:1
SHEET NO. 1 of 1

TITLE CONNECTOR
MODLE USB 3.1 TYPE C 直立式 SMT L10.4mm 外殼腳長1.20mm
DWG NO. SBC-240VSE2C31x-S175
PART NO. SBC-240VSE2C31x-S175

SIZE A4
VER R

ITEM NO.	DESCRIPTION	DRAWN	DATE