

PCB LAYOUT

SPECIFICATION

Electrical :

- 1.Current Rating: 0.5mA AC / DC Max
- 2.Voltage Rating: 125V AC / DC
- 3.Contact Resistance: 100 mΩ Max.
- 4.Insulation Resistance: 1,000 MΩ Min.

Environmental:

- 1.Operating Temperature: -25°C ~ +85°C.

Material:

- 1.Housing: LCP
- 2.Contact: Copper Alloy
- 3.Shell: SUS

Finish:

- 1.Contact: Plated Gold in Mating Area ;  
Tin Plated on Solder Balls ;  
Nickel under plated overall
- 2.Shell: Nickel under Plated surface layer

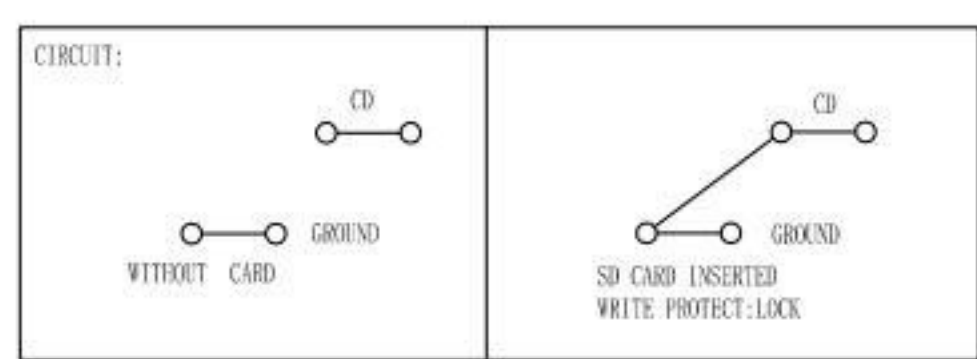
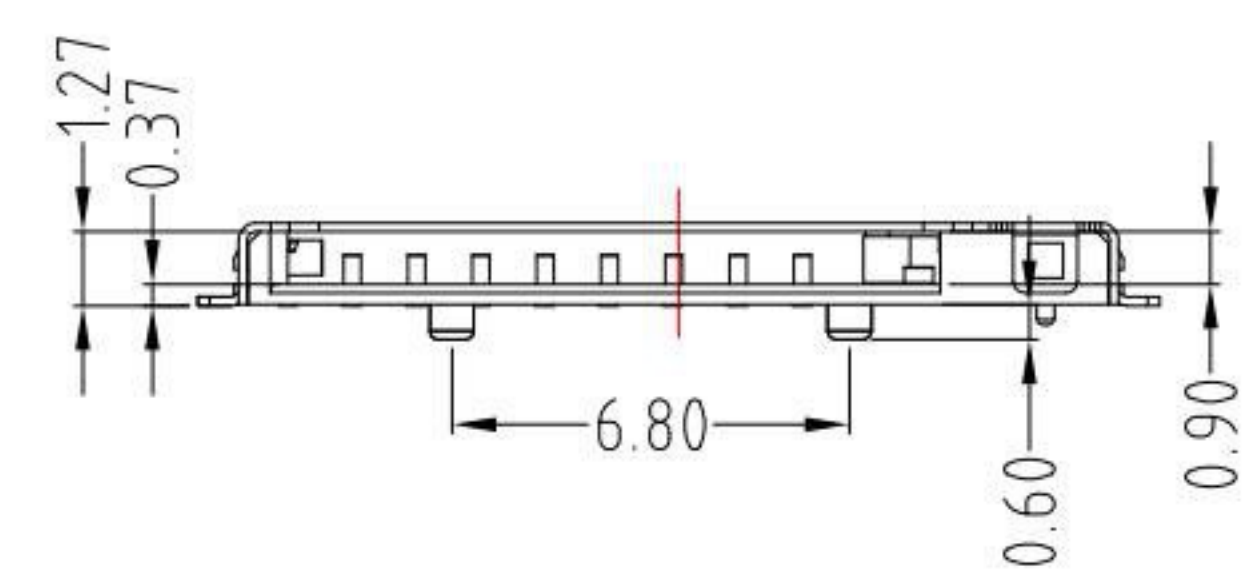

PIN NO.	PIN ASSIGNMENT
1#	DAT2
2#	CD/DAT3
3#	CMD
4#	VDD
5#	CLK
6#	VSS
7#	DAT0
8#	DAT1
9#	CD

**KSD** 科斯达电子科技有限公司  
 SWITCH CONNECTOR KSD ELECTRONIC TECHNOLOGY Co., LTD  
 全球 互联网 零组件 制造企业

TOLERANCE UNLESS OTHERWISE STATED :  
 Up to 5 ±0.2  
 Above 5 ~ 15 ±0.3  
 Above 15 ~ 30 ±0.4  
 Above 30 ~ 50 ±0.5  
 Angle ±0.3

3RD. ANGEL'S

UNITS MM

DRAWN BY:	DATE	MAT'L	TITLE	CONNECTOR
Jack Lu	06/03/20		MODLE	T Flash 卡座 Push H1.4
CHECKED BY:	DATE	FINISH	DWG NO.	SD-TF21-131ZAW-S304
Jacky Chen	06/03/20		PART NO.	SD-TF21-131ZAW-S304
APPROVED BY:	DATE	SCALE	SHEET NO.	1 of 1
Tony Kao	06/03/20	1 : 1		

ITEM NO.	DESCRIPTION	DRAWN	DATE