

RECOMMEND PCB LAYOUT

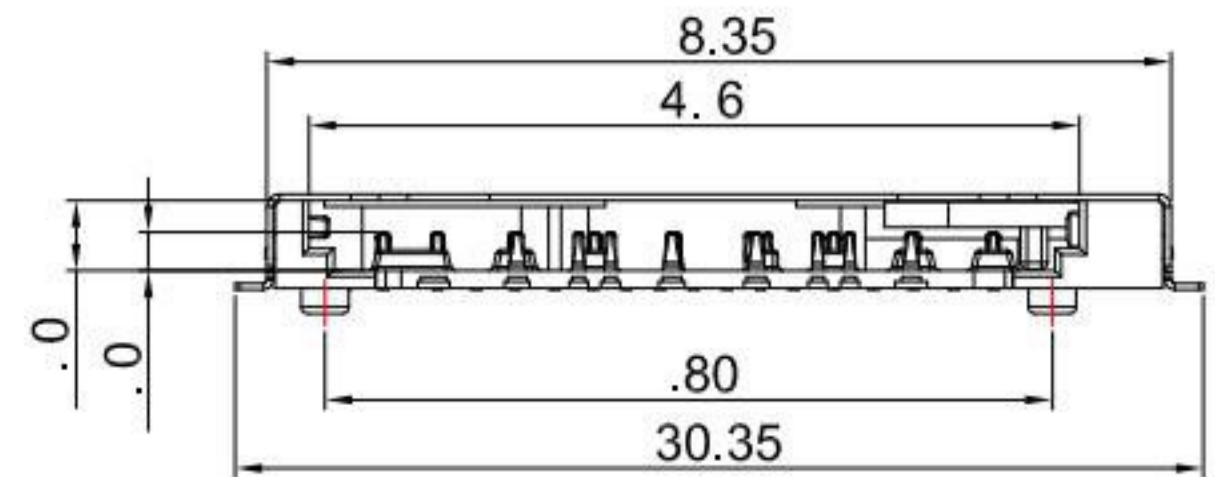

PIN ASSIGNMENT			
PIN NO.	NAME	PIN NO.	NAME
1	VSS3	11	VDD1
2	DAT2	12	D1-
3	D0+	13	CLK
4	CD/DAT3	14	D1+
5	D0-	15	VSS2
6	CMD	16	VSS5
7	CD	17	DAT0
8	VSS1	18	DAT1
9	VSS4	19	WP
10	VDD2		

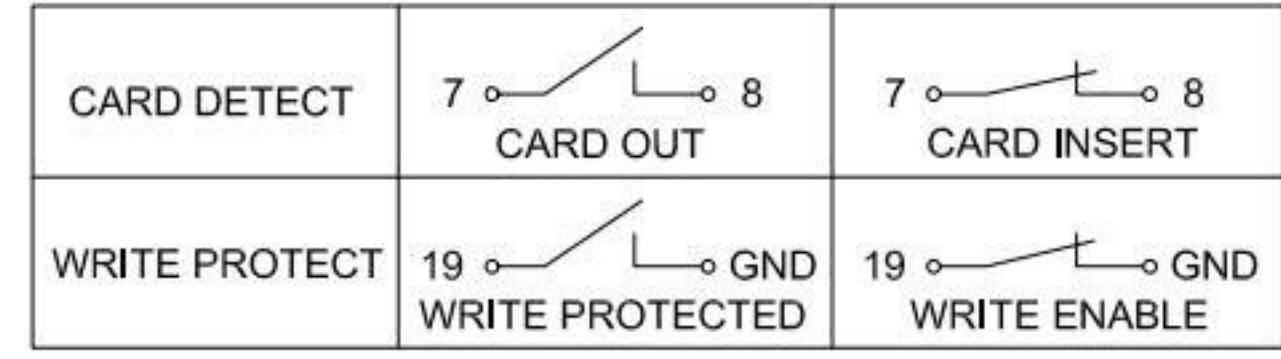

SPECIFICATION

Electrical :

- 1.Current Rating: 1.0A
- 2.Voltage Rating: 250V AC / DC
- 3.Contact Resistance: 100 mΩ Max.
- 4.Insulation Resistance: 1,000 MΩ Min.

Environmental:

- 1.Operating Temperature: -25°C ~ +85°C.

Material:

- 1.Housing: LCP
- 2.Contact: Phosphor Bronze
- 3.Shell: Stainless Steel

Finish:

- 1.Contact: Plated Gold in Mating Area ;
Tin Plated on Solder Balls ;
Nickel under plated overall
- 2.Shell: Nickel under Plated surface layer

KSD 科斯达电子科技有限公司
 SWITCH CONNECTOR KSD ELECTRONIC TECHNOLOGY Co., LTD
 全球 互联网 零组件 制造企业

TOLERANCE UNLESS OTHERWISE STATED :
 Up to 5 ±0.2
 Above 5 ~ 15 ±0.3
 Above 15 ~ 30 ±0.4
 Above 30 ~ 50 ±0.5
 Angle ±0.3

3RD. ANGEL'S

UNITS MM

DRAWN BY:	DATE
Jack Lu	03/09/22
CHECKED BY:	DATE
Jacky Chen	03/09/22
APPROVED BY:	DATE
Tony Kao	03/09/22

MAT'L	TITLE	CONNECTOR
FINISH	MODLE	SD 4.0 H3.0 PUSH PUSH TYPE
SCALE	DWG NO.	SD4-3000-S434
SHEET NO.	PART NO.	SD4-3000-S434
1 : 1		
1 of 1		

1	更新圖面	Jack	030922
ITEM NO.	DESCRIPTION	DRAWN	DATE