

P.C.B LAYOUT
BOTTOM VIEW

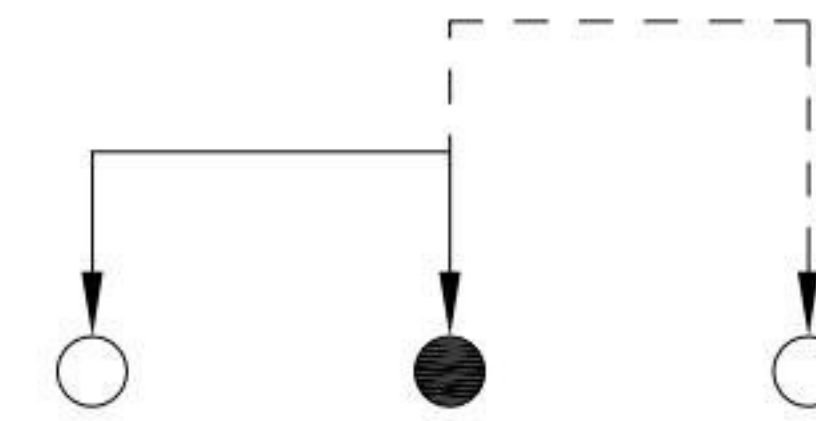

SCHEMATIC

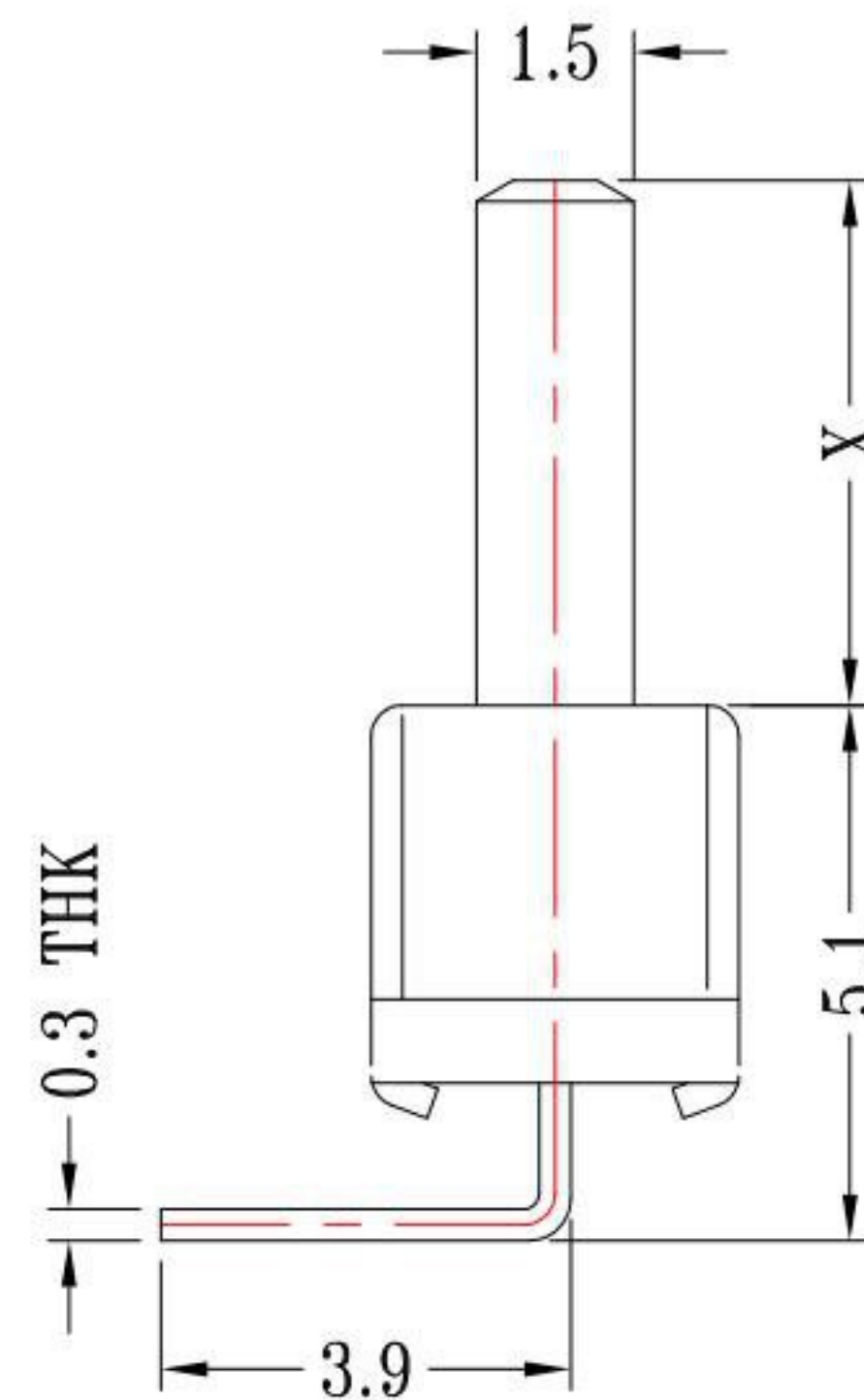
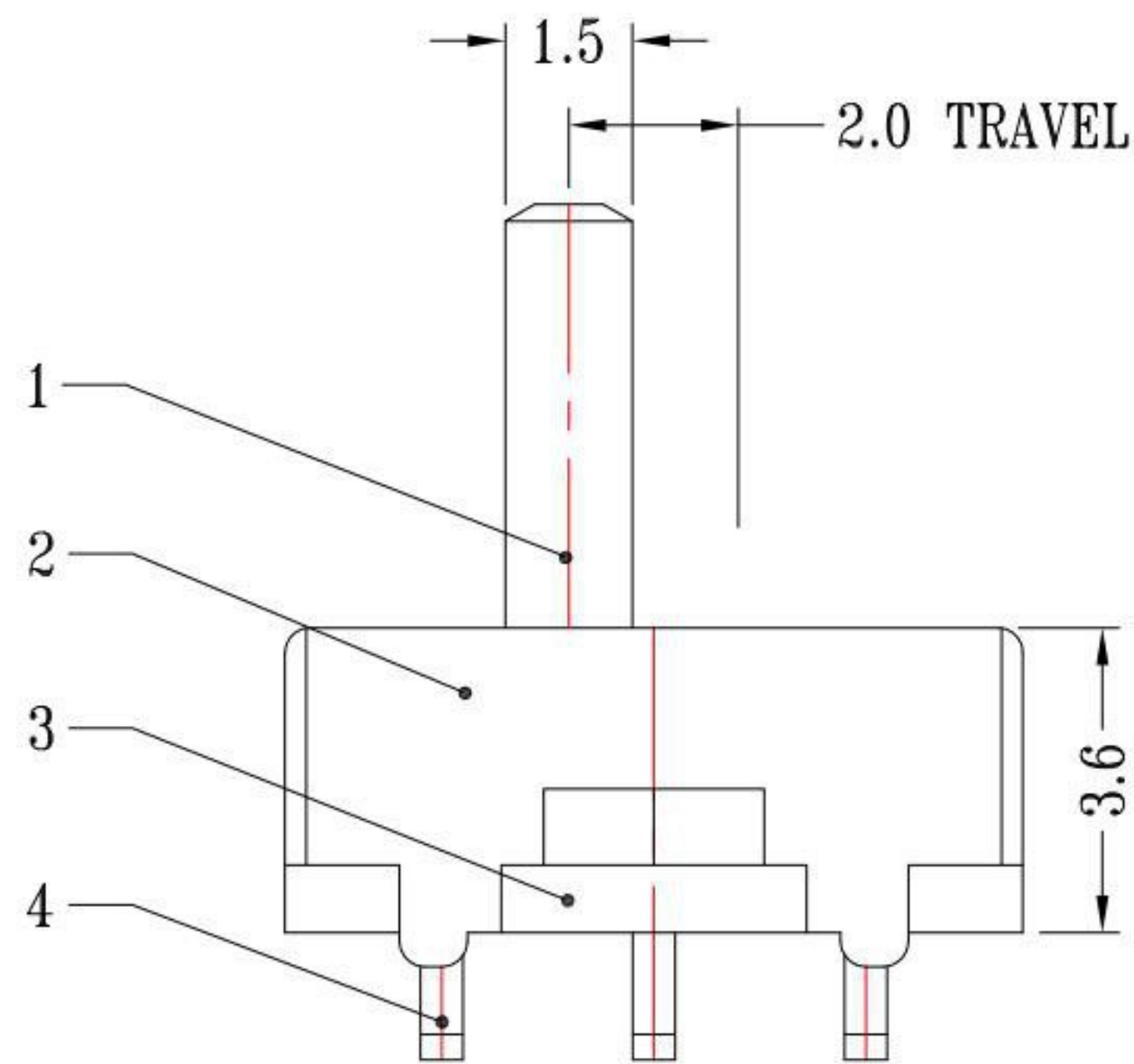

MODEL NO.	X(mm)
SS-12D03-G2-S191	2mm
SS-12D03-G3-S191	3mm
SS-12D03-G4-S191	4mm
SS-12D03-G5-S191	5mm
SS-12D03-G6-S191	6mm
SS-12D03-G7-S191	7mm
SS-12D03-G8-S191	8mm
SS-12D03-G9-S191	9mm

SPECIFICATIONS

Rating	0.3A 50V DC
FUNCTION	1P2T
Contact Resistance	200mΩ Max.
Insulation Resistance	100MΩ Min.
Operating Force	200gf ± 80gf
Operating Life	10,000 cycle

NO.	PARTS	MATERIALS	QTY	FINISH
5	CONTACT CLIP	PBS STRIP	1	Ag PLATED
4	TERMINAL	BRASS	3	Ag PLATED
3	BASE	PHENOLIC RESIN	1	NATURAL
2	FRAME	STEEL STRIP	1	Ni PLATED
1	KNOB	POM	1	BLACK

KSD 科斯达电子科技有限公司
SWITCH CONNECTOR KSD ELECTRONIC TECHNOLOGY Co., LTD
全球 互联零组件制造企业

TOLERANCE UNLESS OTHERWISE STATED:
Up to 5 ±0.2
Above 5 ~ 15 ±0.3
Above 15 ~ 30 ±0.4
Above 30 ~ 50 ±0.5
Angle ±0.3°

3RD. ANGEL'S

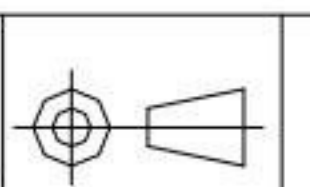

UNITS

MM

DRAWN BY:	DATE	MAT'L	TITLE	SWITCH
Jack Lu	12/29/20	FINISH	MODLE	SLIDE SWITCH
CHECKED BY:	DATE	SCALE	DWG NO.	SS-12D03-Gx-S191
Jacky Chen	12/29/20	SHEET NO.	PART NO.	SS-12D03-Gx-S191
APPROVED BY:	DATE	1 of 1		
Tony Kao	12/29/20			

ITEM NO.	DESCRIPTION	DRAWN	DATE
3	新增尺寸	Jack	122920
2	新增SPEC	Jack	111914
1	新增尺寸	Jack	061614