

CIRCUIT DIAGRAM

P.C.B LAND PATTERN

SPECIFICATIONS

|                                 |                    |
|---------------------------------|--------------------|
| Rating                          | 0.3A 6V DC         |
| Insulation Resistance           | 50MΩ Min.          |
| Dielectric Withstanding Voltage | AC 250 V(50Hz)1min |
| Contact Resistance              | 100mΩ Max.         |
| Operating Force                 | 200 ± 50gf         |
| Operating Life                  | 10,000 cycles      |

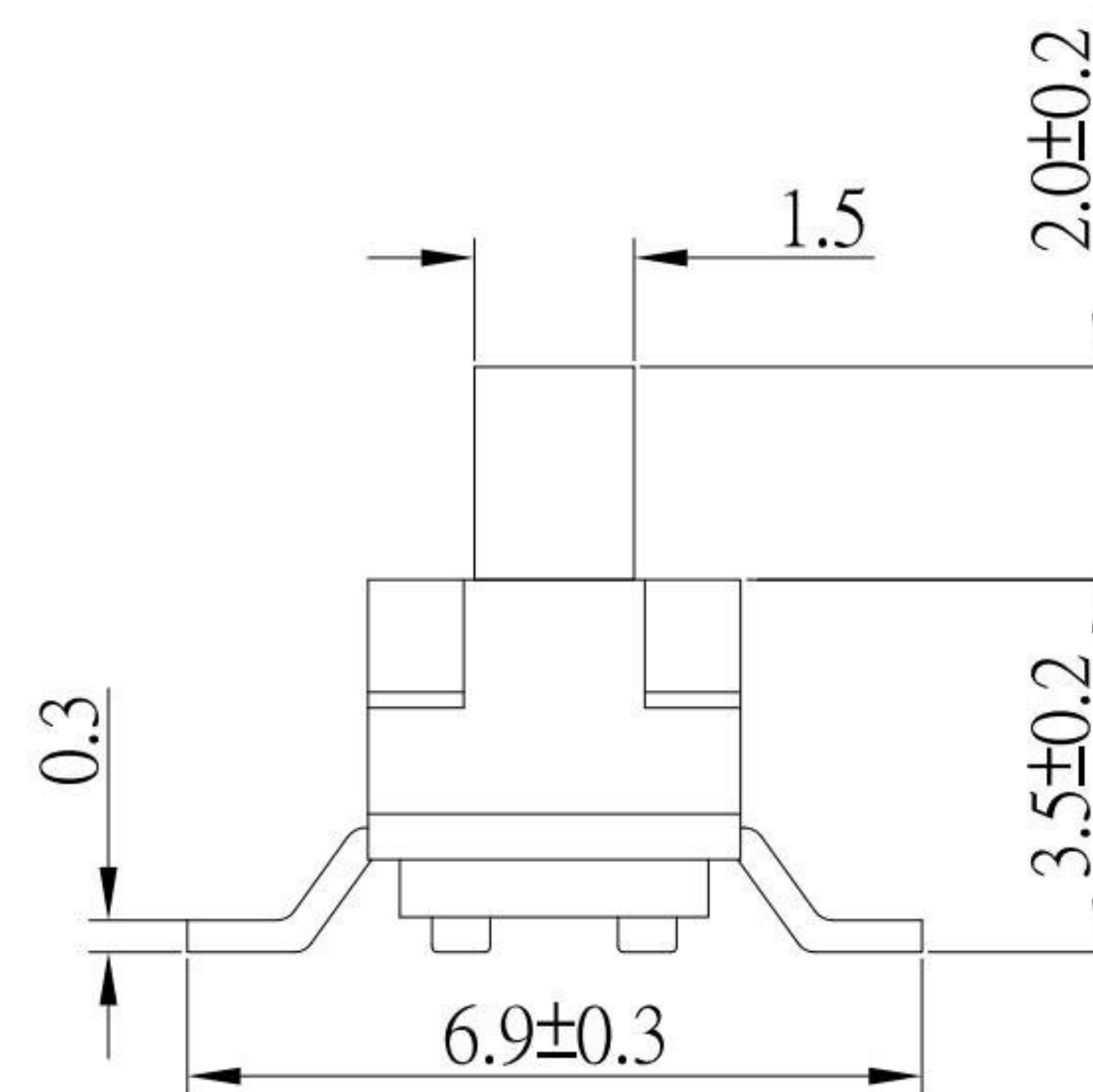
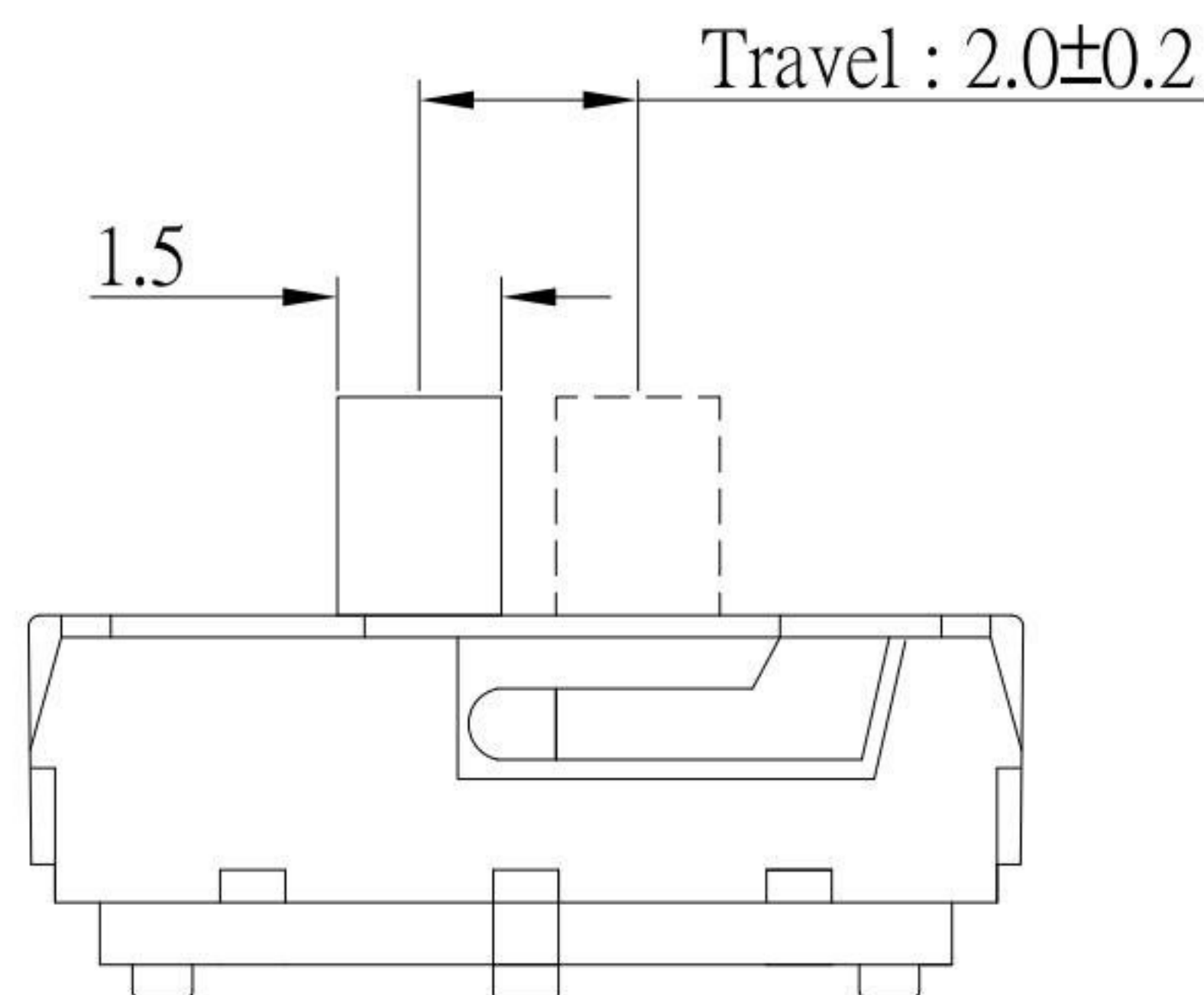

| NO. | DESCRIPTION | QTY | MATERIAL        | PLATING   |
|-----|-------------|-----|-----------------|-----------|
| E   | TERMINAL    | 3   | PHOSPHOR BRONZE | Ag plated |
| D   | CLIP        | 2   | PHOSPHOR BRONZE | Ag plated |
| C   | COVER       | 1   | SUS             |           |
| B   | CASE        | 1   | NYLON           | Black     |
| A   | SLIDER      | 1   | NYLON           | Black     |

**KSD** 科斯达电子科技有限公司  
 SWITCH CONNECTOR KSD ELECTRONIC TECHNOLOGY Co., LTD  
 全球 互联零组件制造企业

TOLERANCE UNLESS OTHERWISE STATED:  
 Up to 5 ±0.2  
 Above 5 ~ 15 ±0.3  
 Above 15 ~ 30 ±0.4  
 Above 30 ~ 50 ±0.5  
 Angle ±0.3°

3RD. ANGEL'S

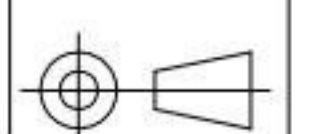

UNITS MM

DRAWN BY: Jack Lu  
 CHECKED BY: Jacky Chen  
 APPROVED BY: Tony Kao

DATE: 08/24/21  
 DATE: 08/24/21  
 DATE: 08/24/21

MAT'L  
 FINISH  
 SCALE: 1:1  
 SHEET NO. 1 of 1

TITLE: SWITCH  
 MODLE: SLIDE SWICTH  
 DWG NO.: SS-B35S-B-S246  
 PART NO.: SS-B35S-B-S246

SIZE: A4  
 VER: R1

| ITEM NO. | DESCRIPTION | DRAWN | DATE   |
|----------|-------------|-------|--------|
| 1        | 新增Travel    | Jack  | 082421 |