

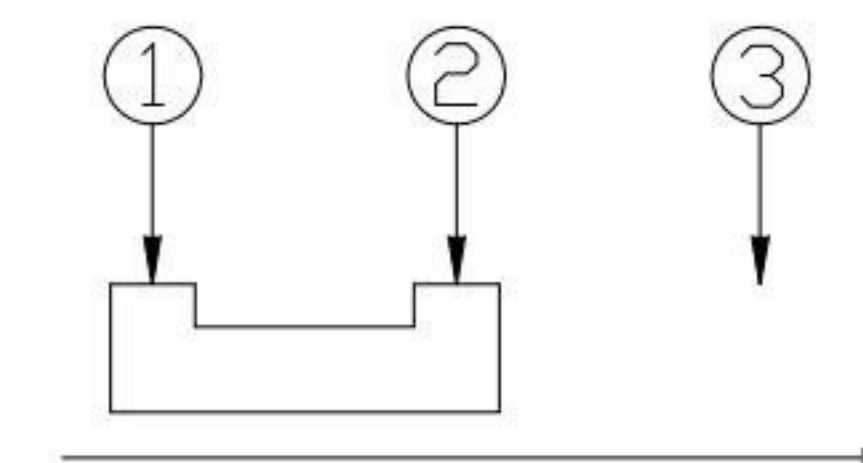

# SS-B45x-B-S246

Model No.	X (mm)
SS-B45	2.0
SS-B45A	3.0
SS-B45C	4.0



CIRCUIT DIAGRAM

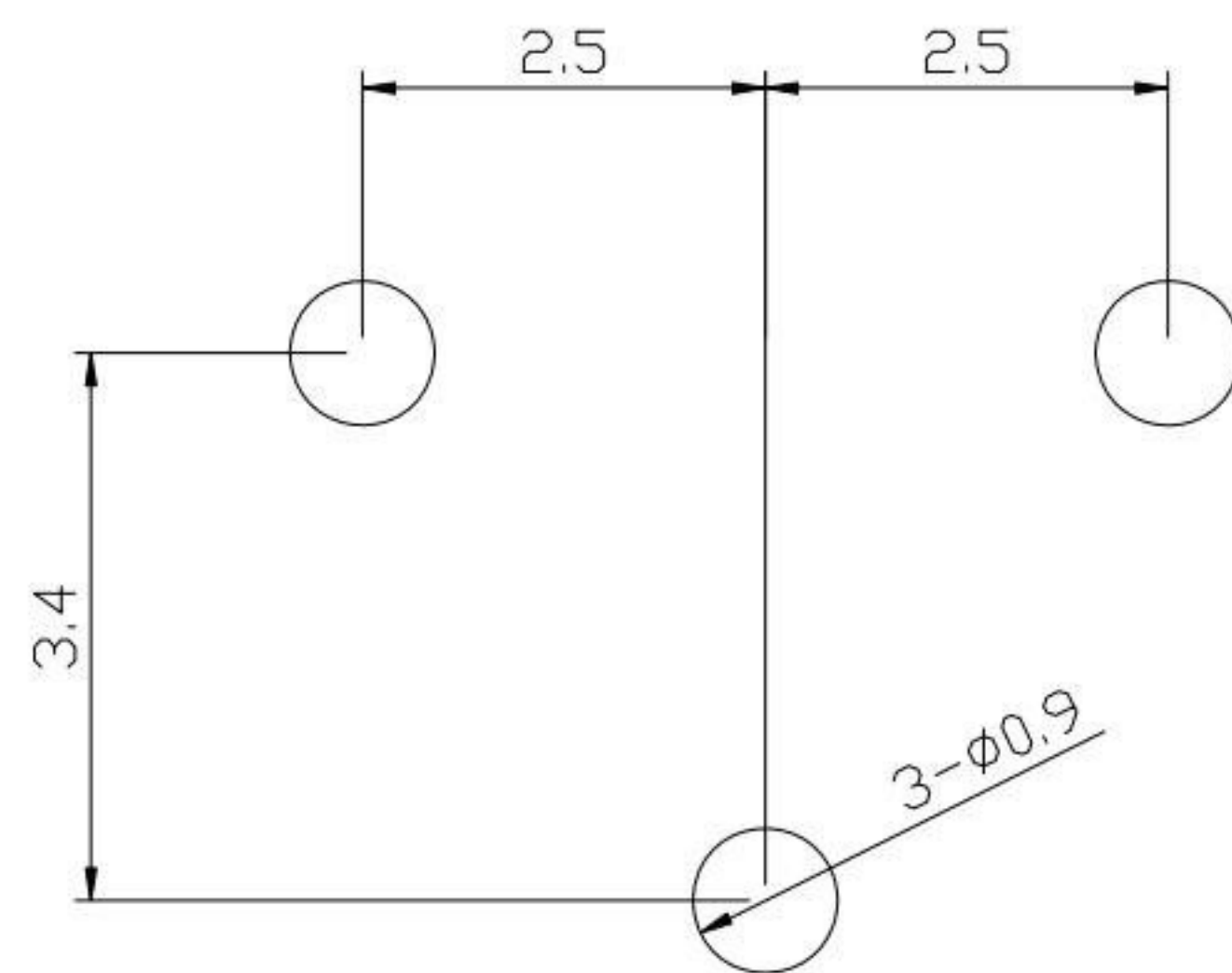

P.C.B LAND PATTERN

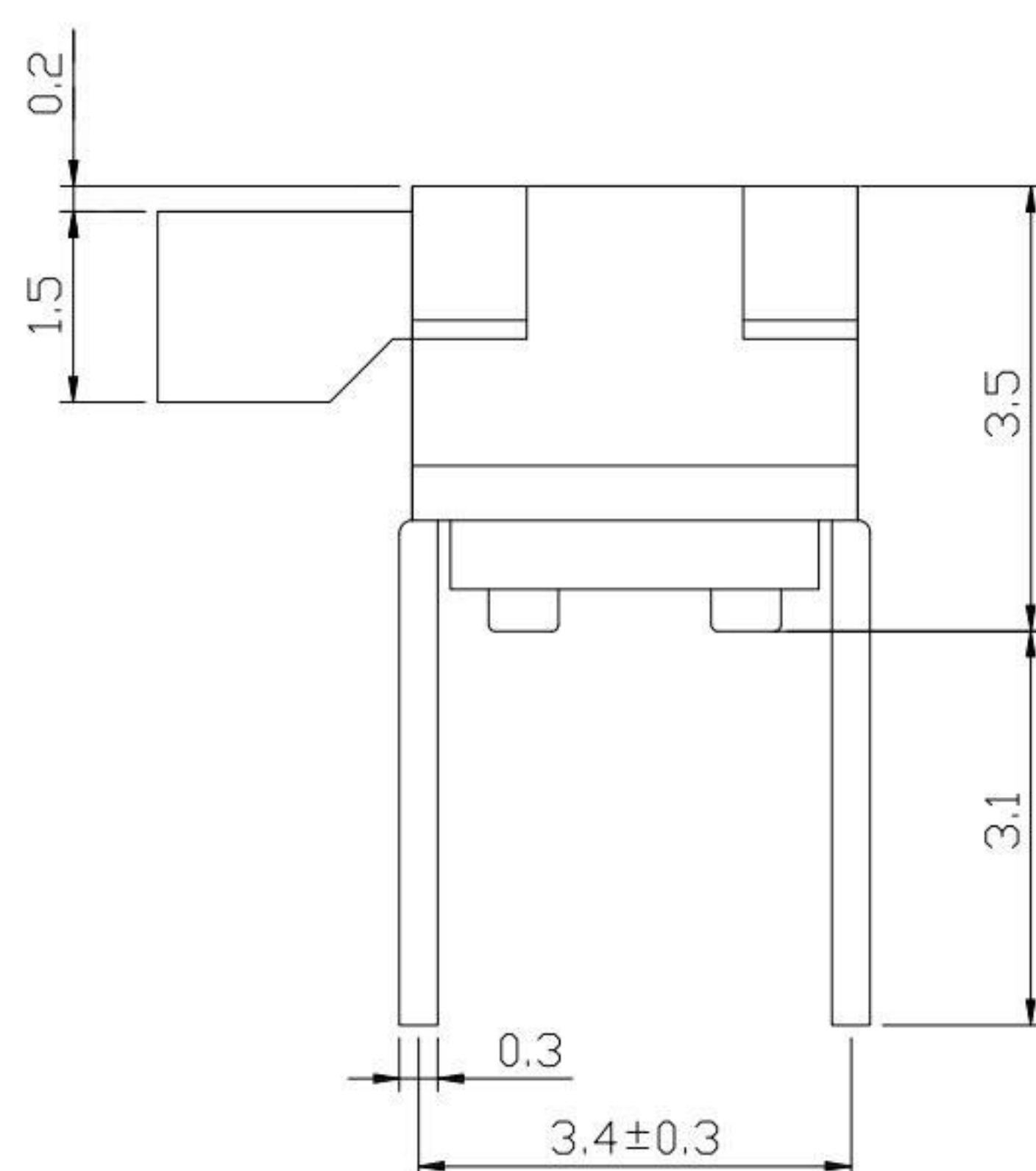
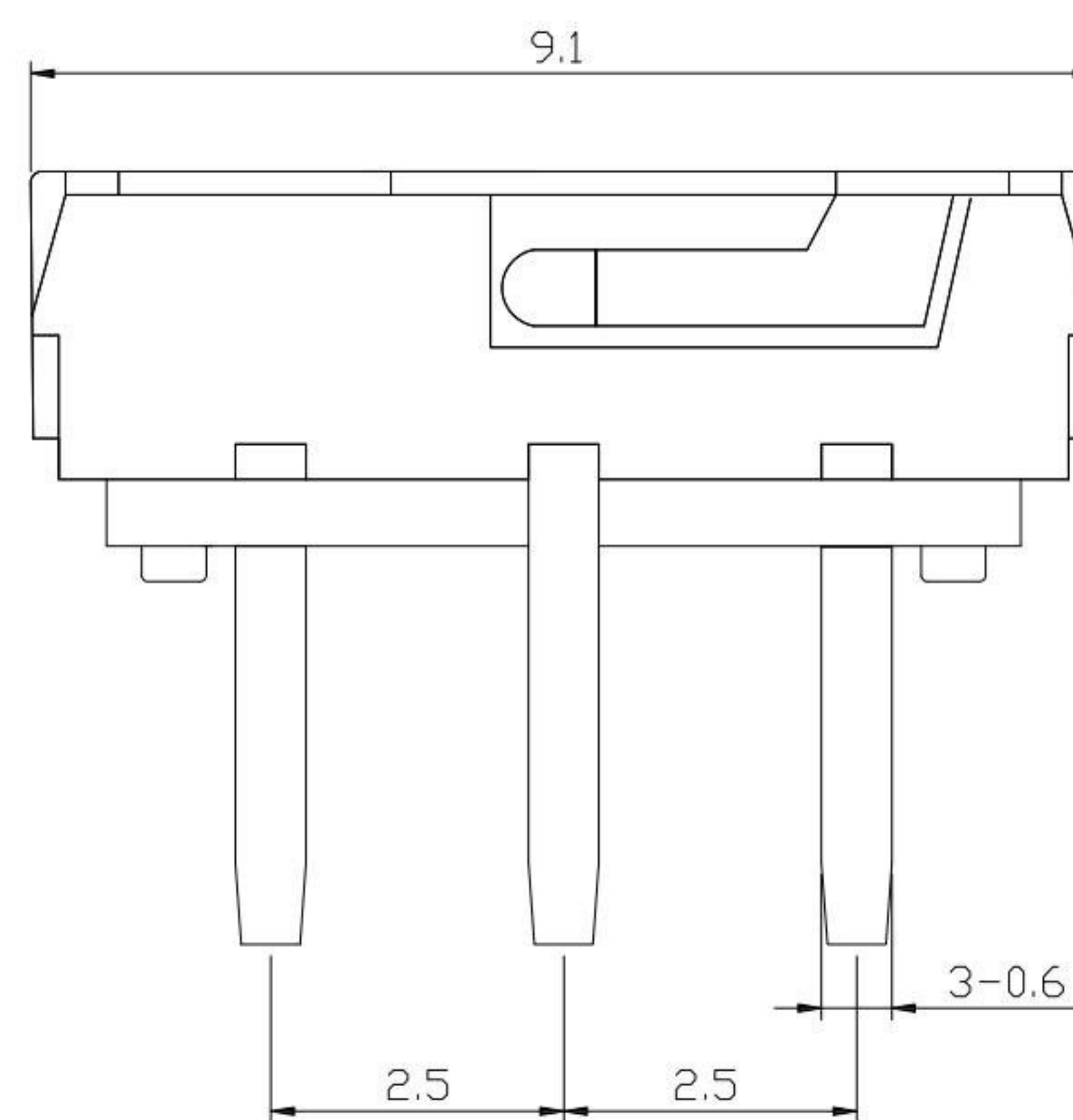
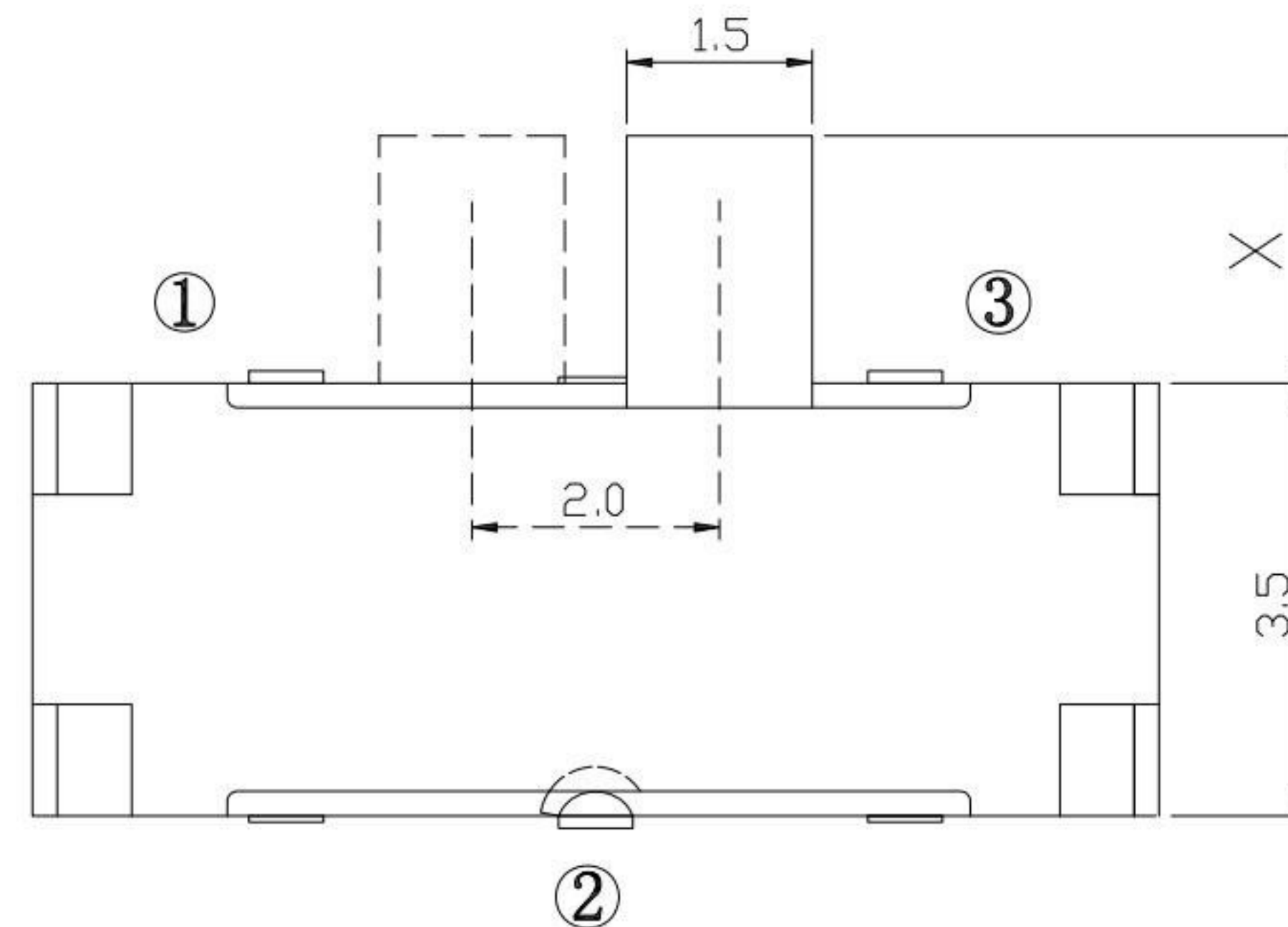

## SPECIFICATIONS

Rating	0.3A 6V DC
Insulation Resistance	50MΩ Min.
Dielectric Withstanding Voltage	AC 250 V(50Hz)1min
Contact Resistance	100mΩ Max.
Operating Force	200 ± 50gf
Operating Life	10,000 cycles

NO.	DESCRIPTION	QTY	MATERIAL	PLATING
E	TERMINAL	3	PHOSPHOR BRONZE	Ag plated
D	CLIP	1	PHOSPHOR BRONZE	Ag plated
C	COVER	1	SUS	
B	CASE	1	PA46	Black
A	SLIDER	1	PA46	Black

**KSD** 科斯达电子科技有限公司  
 SWITCH CONNECTOR KSD ELECTRONIC TECHNOLOGY Co., LTD  
 全球 互聯零組件 制造企业

TOLERANCE UNLESS OTHERWISE STATED:	Up to 5 ±0.2	3RD. ANGEL'S	UNITS	MM
	Above 5 ~ 15 ±0.3			
	Above 15 ~ 30 ±0.4			
	Above 30 ~ 50 ±0.5			
	Angle ±0.3°			

DRAWN BY:	DATE	MAT'L	TITLE	SWITCH
Jack Lu	04/09/21		MODLE	SLIDE SWICTH
CHECKED BY:	DATE	SCALE	DWG NO.	SS-B45x-B-S246
Jacky Chen	04/09/21	1:1	PART NO.	SS-B45x-B-S246
APPROVED BY:	DATE	SHEET NO.		
Tony Kao	04/09/21	1 of 1		

ITEM NO.	DESCRIPTION	DRAWN	DATE
1	新增柄長選項	Jack	040921

SIZE	A4
VER	R1