

CIRCUIT DIAGRAM

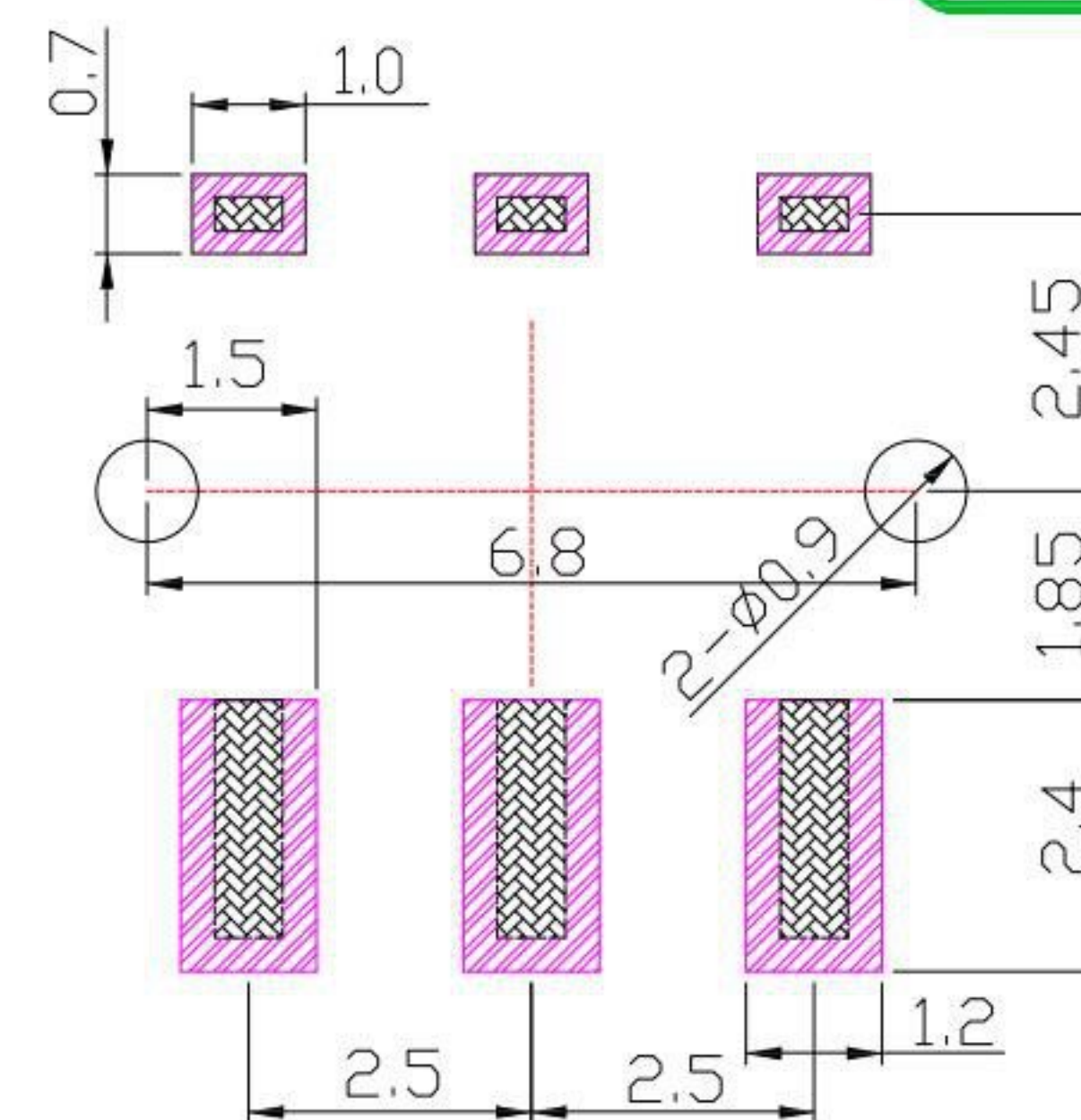

P.C.B LAND PATTERN

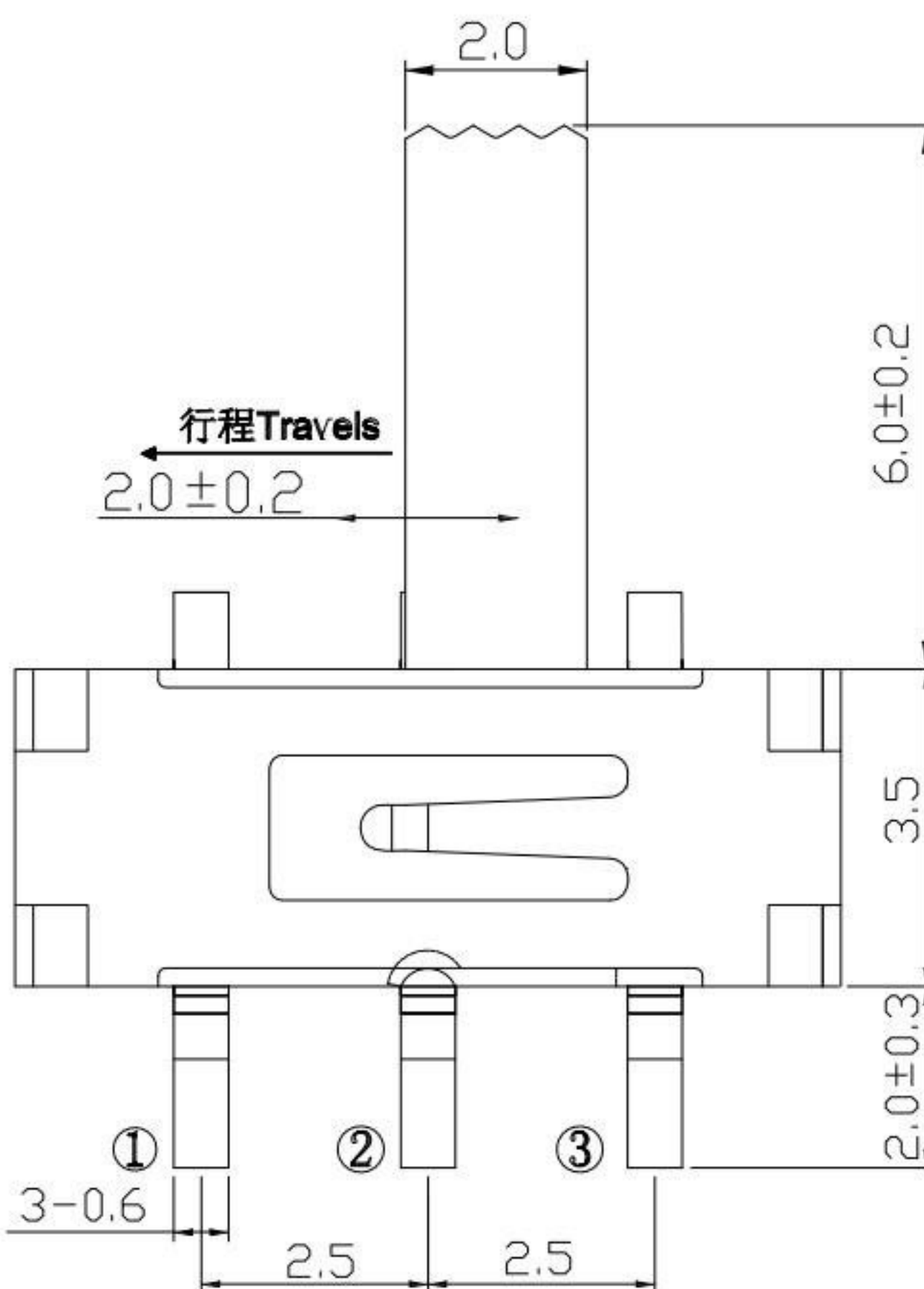
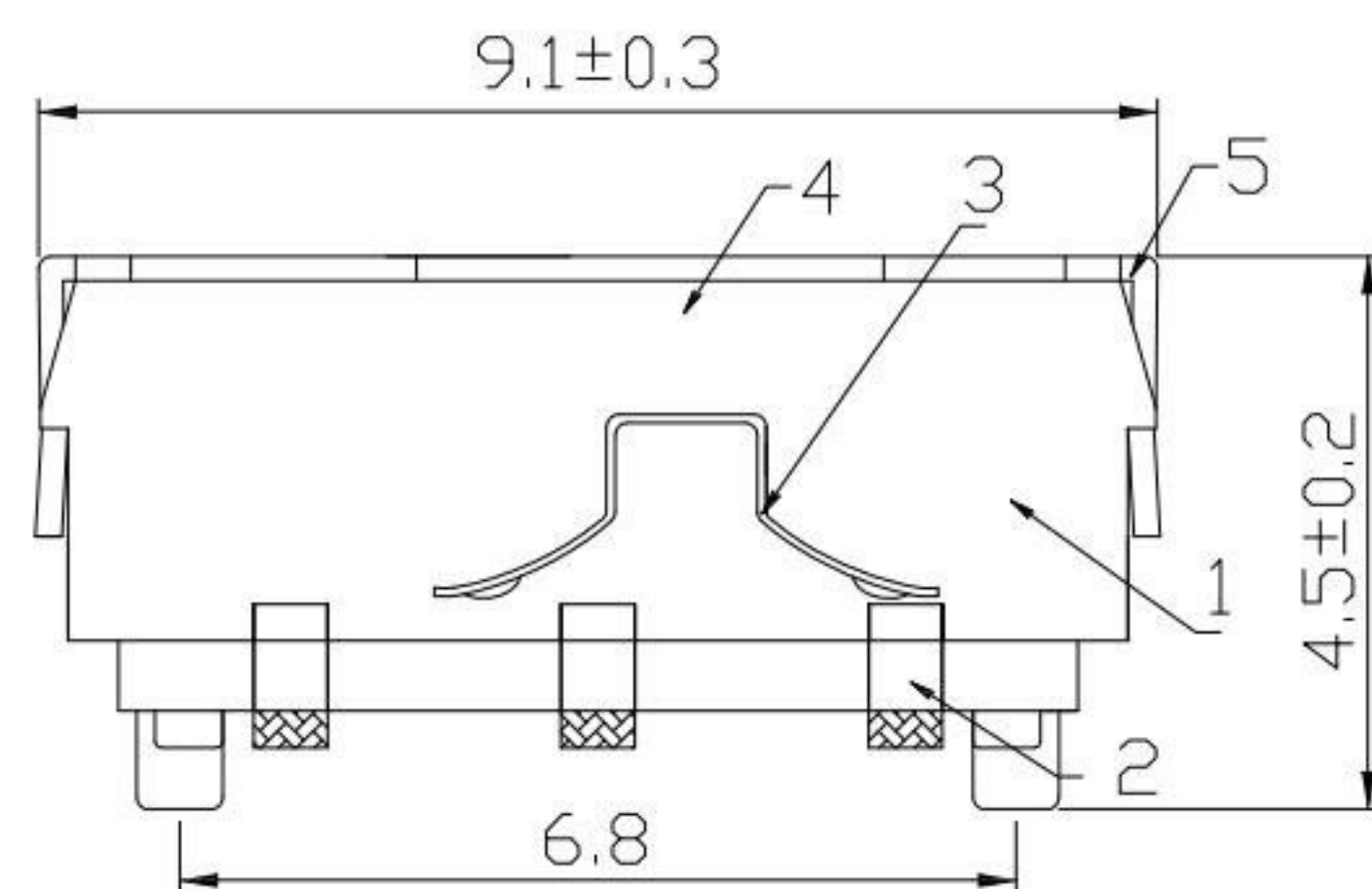
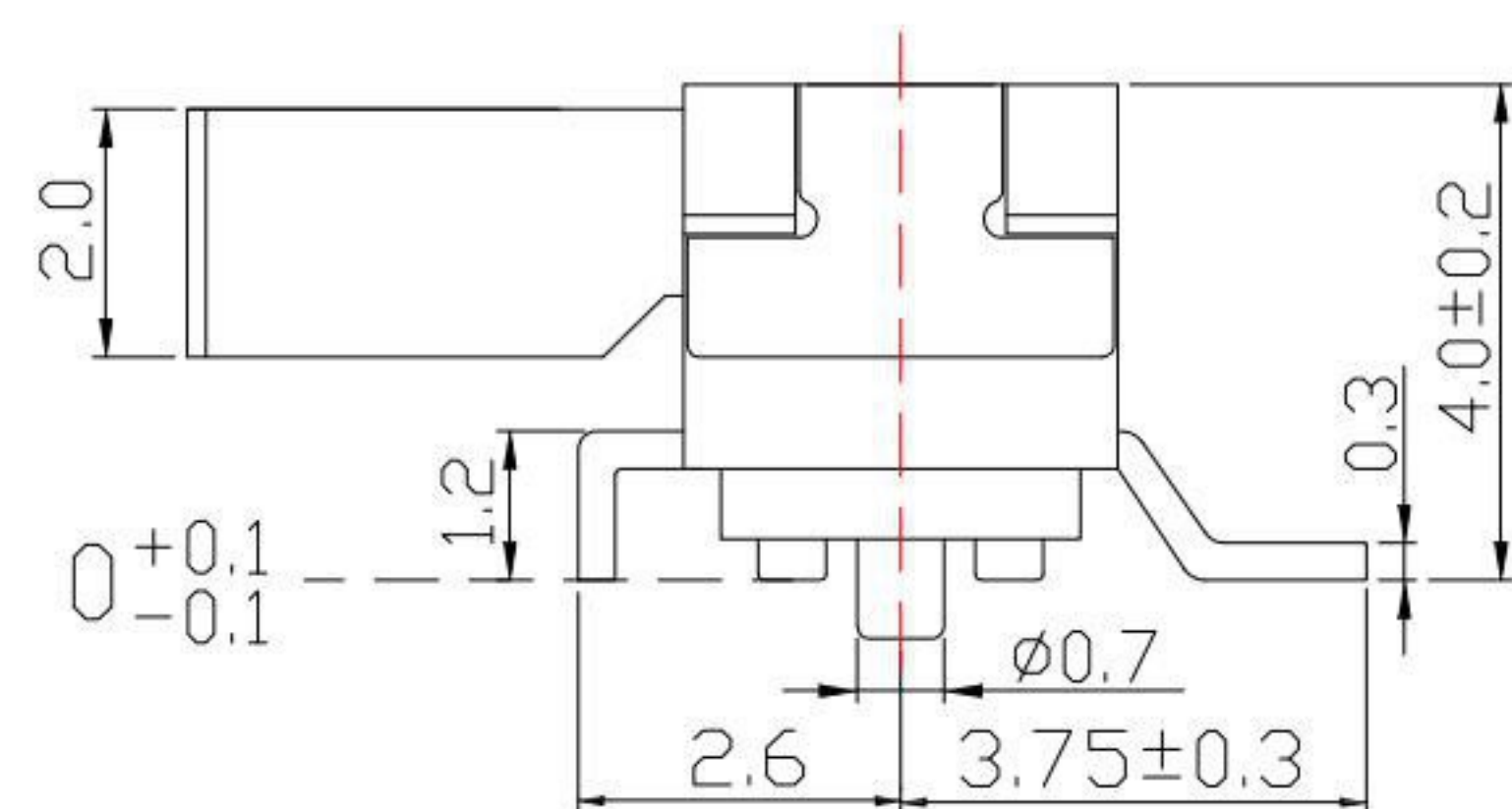

SPECIFICATIONS

Rating	100mA , 12V DC
Insulation Resistance	100MΩ Min.
Dielectric Withstanding Voltage	AC 250 V(50Hz)1min
Contact Resistance	100mΩ Max.
Operating Force	200 ± 70gf
Operating Life	10,000 cycles

NO.	DESCRIPTION	QTY	MATERIAL	PLATING
E	TERMINAL	3	PHOSPHOR BRONZE	Ag plated
D	CLIP	2	PHOSPHOR BRONZE	Ag plated
C	COVER	1	SUS	
B	BASE	1	PA	Black
A	SLIDER	1	PA	Black

KSD 科斯达电子科技有限公司
 SWITCH CONNECTOR KSD ELECTRONIC TECHNOLOGY Co., LTD
 全球 互联零组件制造企业

TOLERANCE UNLESS OTHERWISE STATED:
 Up to 5 ±0.2
 Above 5 ~ 15 ±0.3
 Above 15 ~ 30 ±0.4
 Above 30 ~ 50 ±0.5
 Angle ±0.3

3RD. ANGEL'S

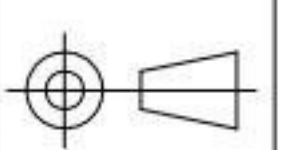

UNITS MM

DRAWN BY: Jack Lu DATE: 09/09/21
 CHECKED BY: Jacky Chen DATE: 09/09/21
 APPROVED BY: Tony Kao DATE: 09/09/21

MAT'L TITLE SWITCH
 FINISH MODLE SLIDE SWICTH
 SCALE 1 : 1 DWG NO. SS-B81C-B-S246
 SHEET NO. 1 of 1 PART NO. SS-B81C-B-S246

SIZE A4
 VER R

ITEM NO.	DESCRIPTION	DRAWN	DATE