

CIRCUIT DIAGRAM

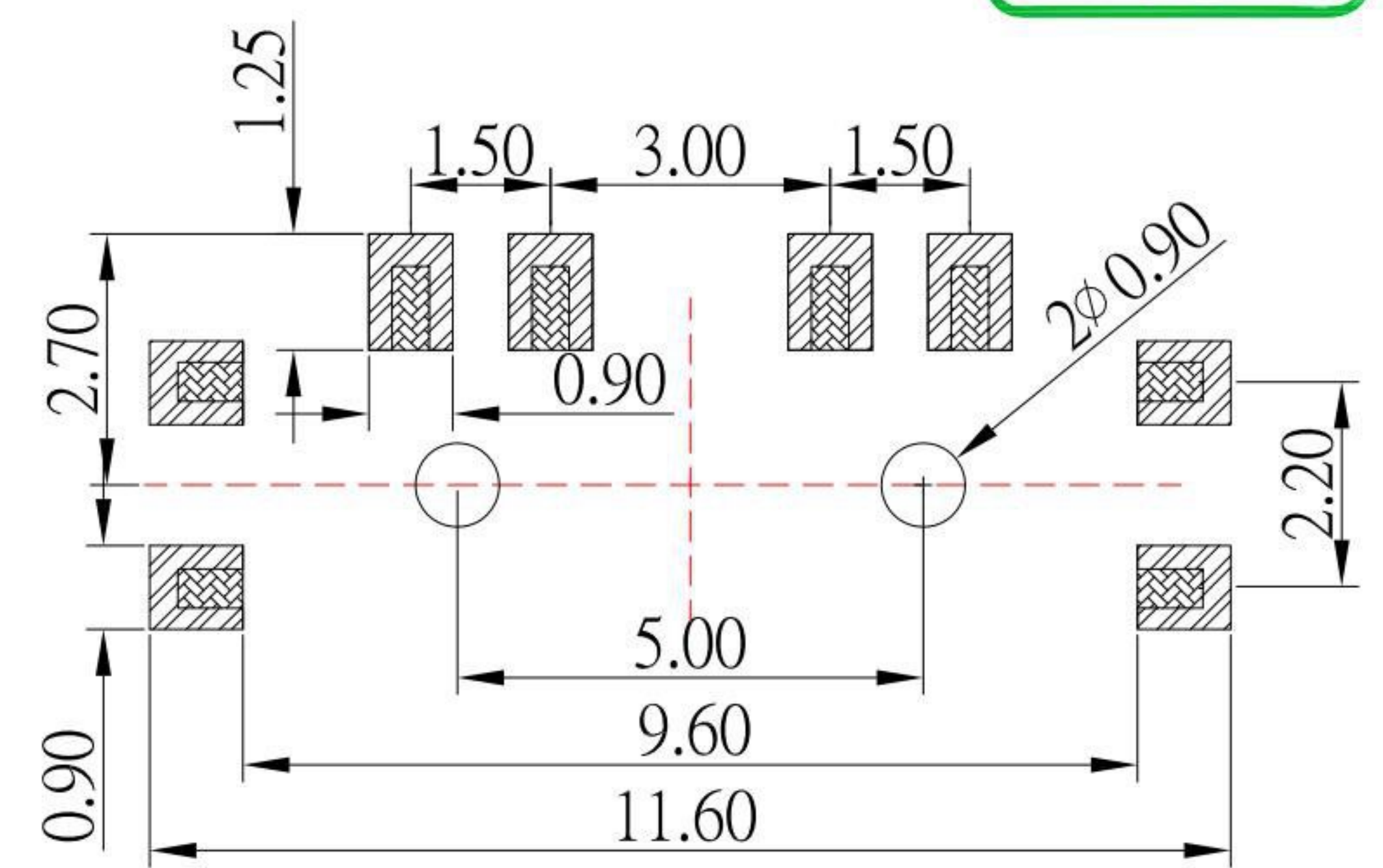

P.C.B LAND PATTERN

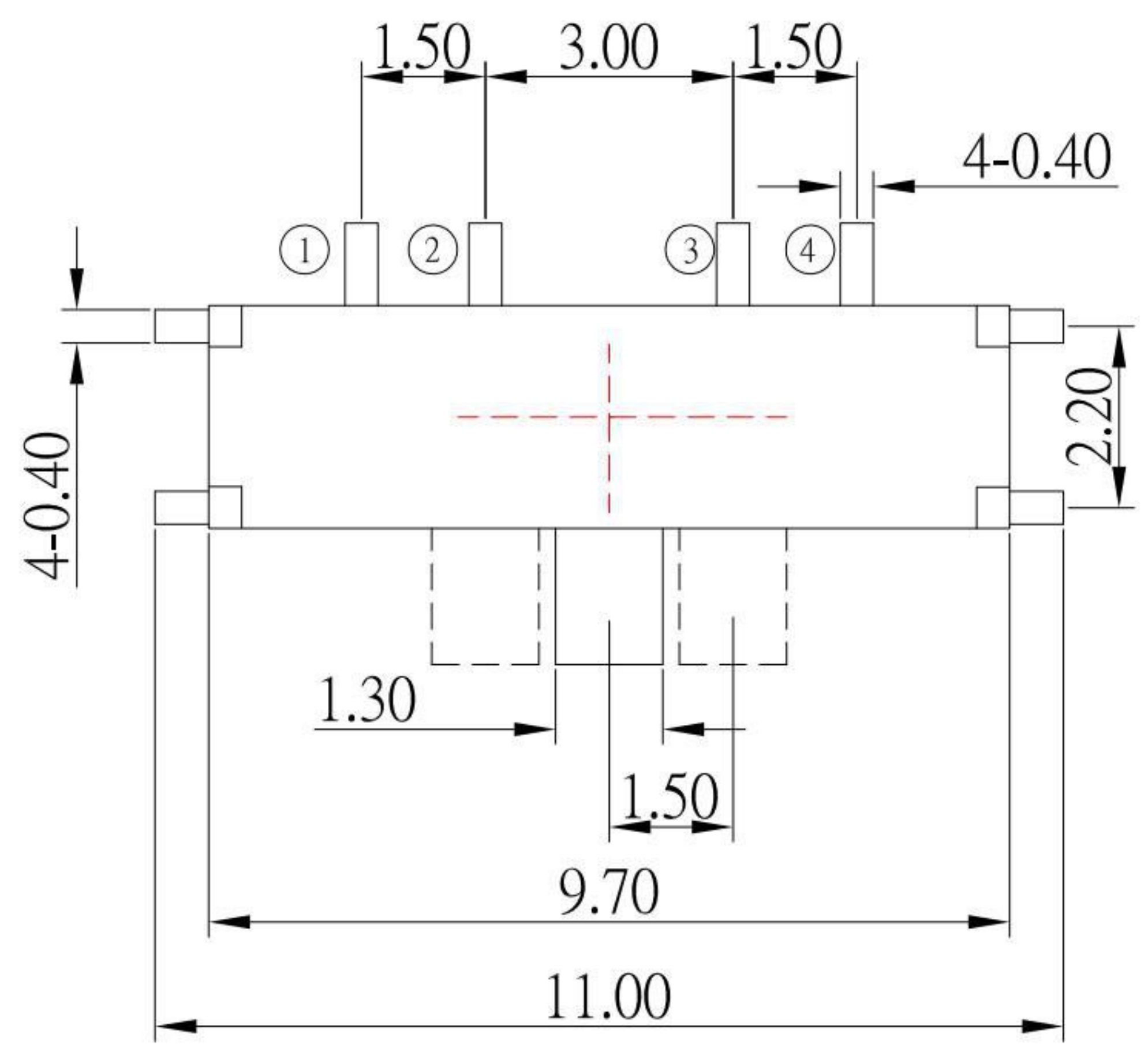
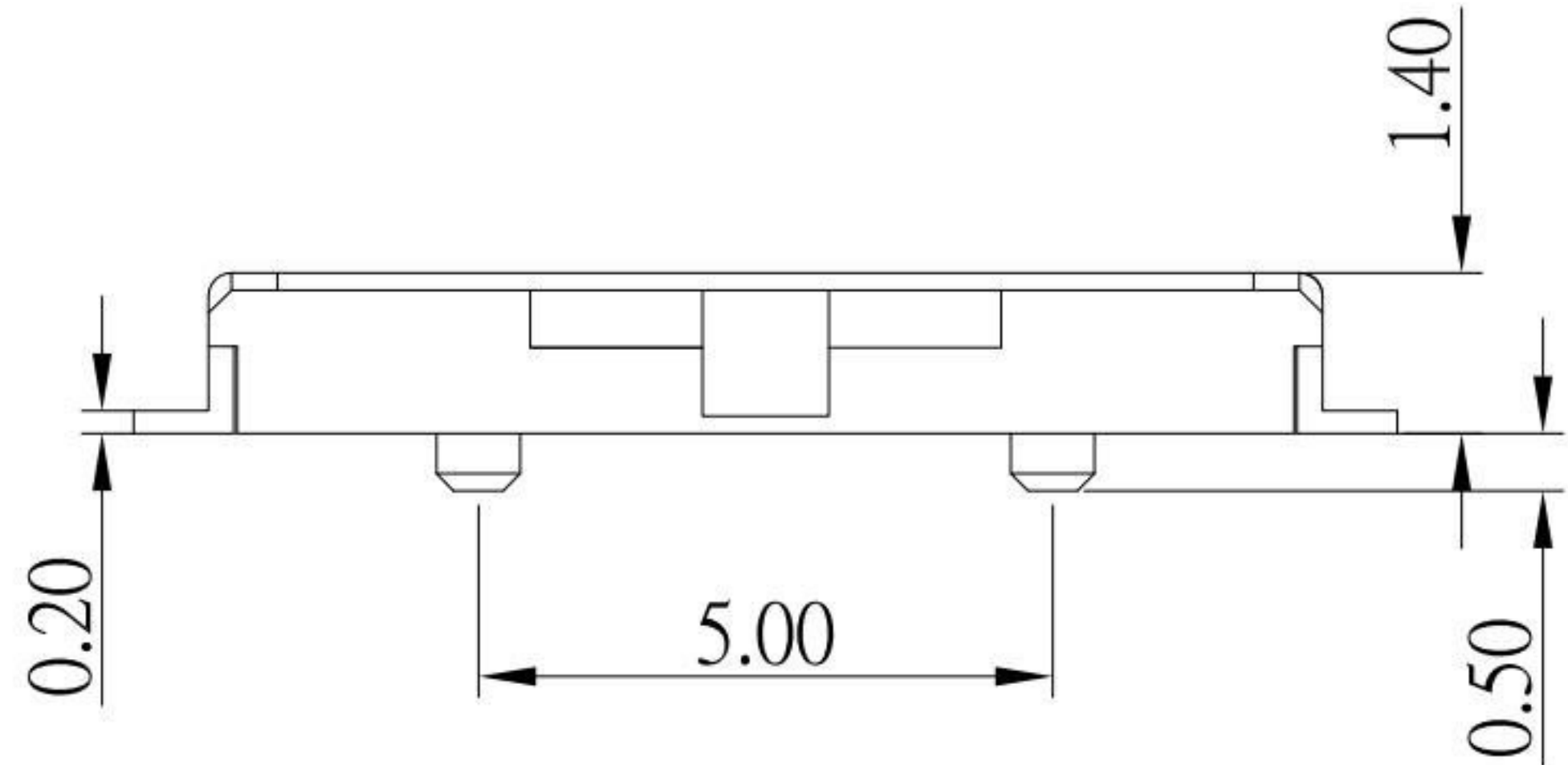
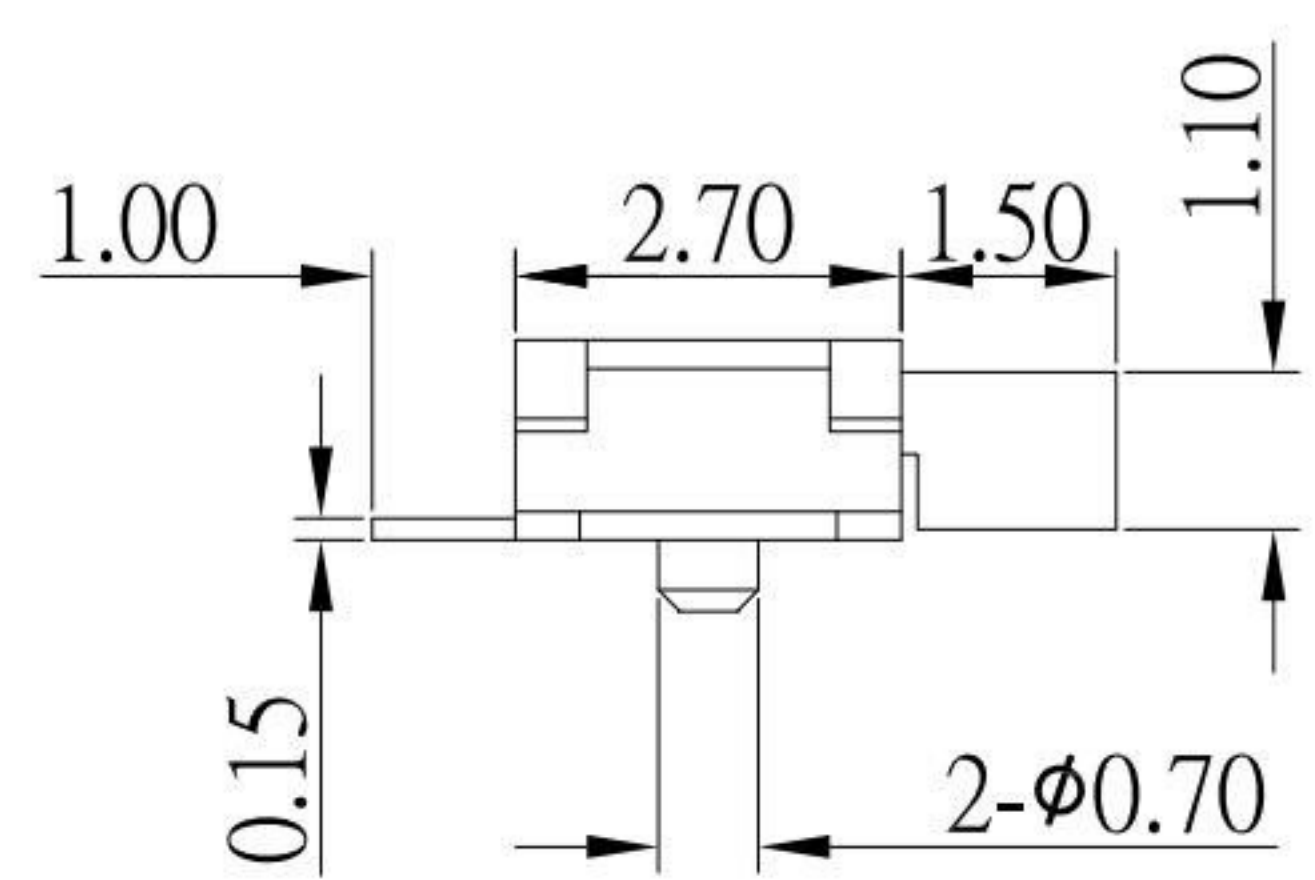

SPECIFICATIONS

Rating	50mA 12V DC
Insulation Resistance	100MΩ Min.
Dielectric Withstanding Voltage	AC 100 V(50Hz)1min
Contact Resistance	100mΩ Max.
Operating Force	200 ± 60gf
Operating Life	10,000 cycles

NO.	DESCRIPTION	QTY	MATERIAL	PLATING
F	SPRING	1	SUS	
E	TERMINAL	4	PHOSPHOR BRONZE	Ag plated
D	CLIP	1	PHOSPHOR BRONZE	Ag plated
C	COVER	1	PHOSPHOR BRONZE	Ag plated
B	CASE	1	LCP	Black
A	SLIDER	1	PA46	Black

KSD 科斯达电子科技有限公司
 SWITCH CONNECTOR KSD ELECTRONIC TECHNOLOGY Co., LTD
 全球 互联零组件制造企业

TOLERANCE UNLESS OTHERWISE STATED:
 Up to 5 ±0.2
 Above 5 ~ 15 ±0.3
 Above 15 ~ 30 ±0.4
 Above 30 ~ 50 ±0.5
 Angle ±0.3°

3RD. ANGEL'S

UNITS MM

DRAWN BY:	DATE	MAT'L	TITLE	SWITCH
Jack Lu	08/10/21		MODLE	SLIDE SWITCH
CHECKED BY:	DATE	SCALE	DWG NO.	SS-C00AP-B-S246
Jacky Chen	08/10/21	1:1	PART NO.	SS-C00AP-B-S246
APPROVED BY:	DATE	SHEET NO.	1 of 1	
Tony Kao	08/10/21			

ITEM NO.	DESCRIPTION	DRAWN	DATE
3	更新材質	Jack	081021
2	更新SPEC	Jack	080521
1	更新CIRCUIT DIAGRAM	Jack	111115

SIZE A4
 VER R3