

P.C.B LAND PATTERN

SPECIFICATIONS

Rating	0.3A 4V DC
Insulation Resistance	50MΩ Min.
Dielectric Withstanding Voltage	AC 250 V(50Hz)1min
Contact Resistance	100mΩ Max.
Operating Force	200 ± 50gf
Operating Life	10,000 cycles

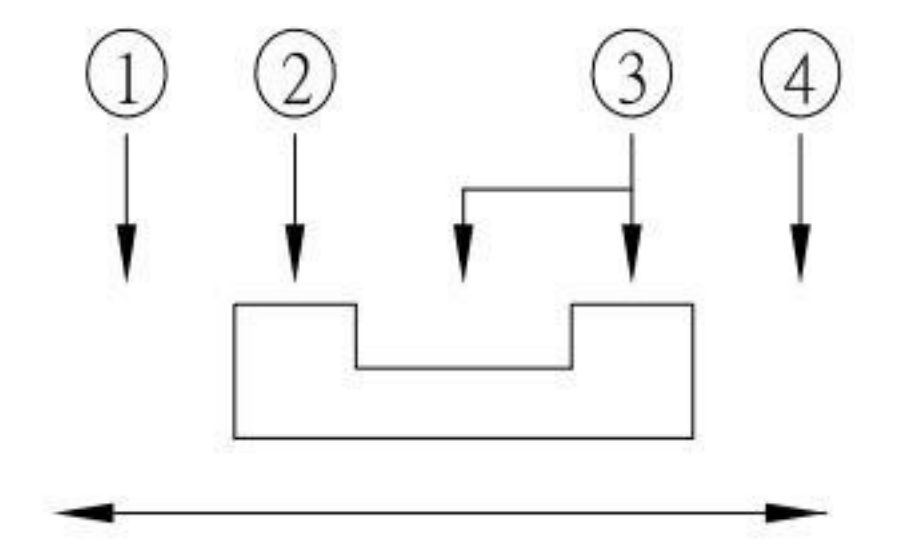
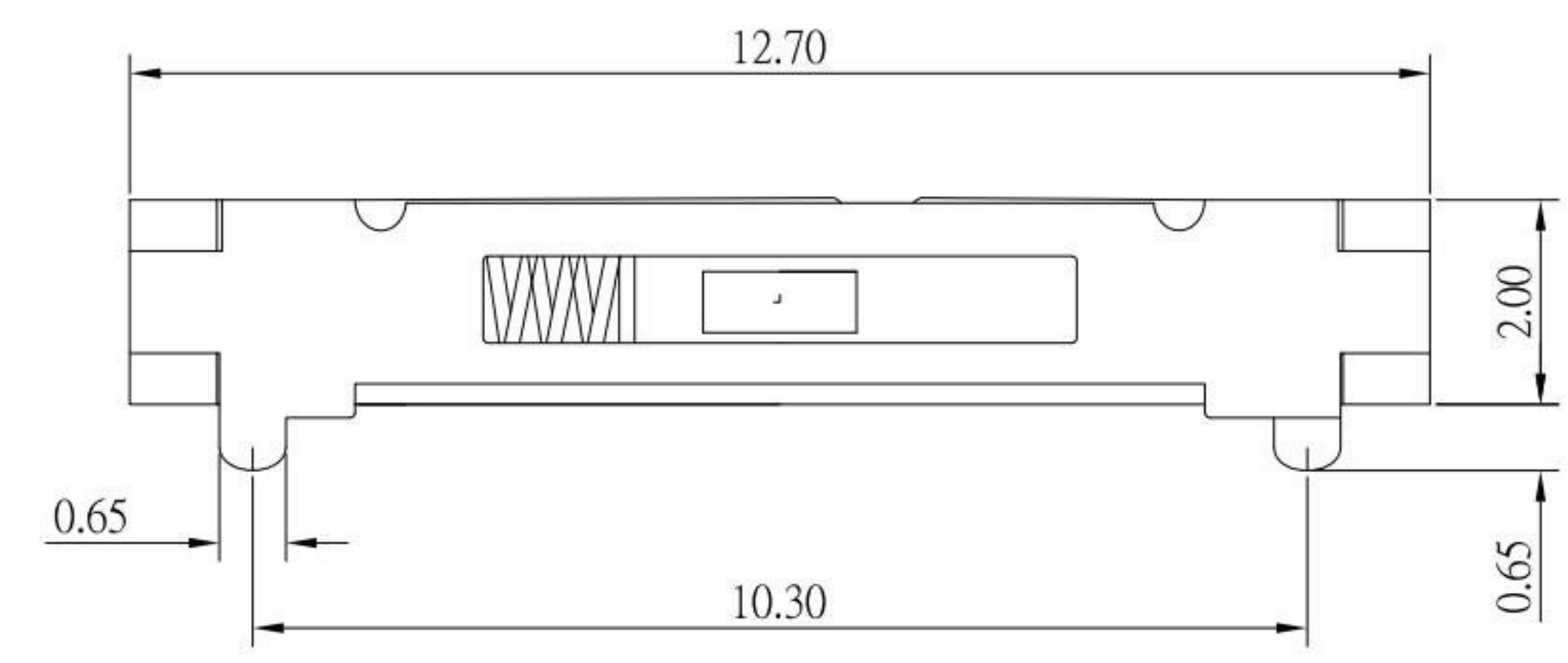

CIRCUIT DIAGRAM

NO.	DESCRIPTION	QTY	MATERIAL	PLATING
E	SPRING	1	SUS	
E	TERMINAL	4	PHOSPHOR BRONZE	Ag plated
D	CLIP	1	BECU	Ag plated
C	COVER	1	SUS	
B	CASE	1	LCP	Black
A	SLIDER	1	PA46	Black

ITEM NO.	DESCRIPTION	DRAWN	DATE
5	更新SPEC及材質	Jack	100814
4	更新為A0版	Jack	020514
3	新增SPRING圖示	Jack	011314
2	新增撥柄位置識意圖	Jack	010914
1	更新Rating	Jack	062813

KSD 科斯达电子科技有限公司
 SWITCH CONNECTOR KSD ELECTRONIC TECHNOLOGY Co., LTD
 全球 互聯零組件 制造企业

TOLERANCE UNLESS OTHERWISE STATED:
 Up to 5 ±0.2
 Above 5 ~ 15 ±0.3
 Above 15 ~ 30 ±0.4
 Above 30 ~ 50 ±0.5
 Angle ±0.3

3RD. ANGEL'S

UNITS MM

DRAWN BY:	DATE	MAT'L	TITLE	SWITCH
Jack Lu	10/08/14		MODLE	SMT SLIDE SWICTH
CHECKED BY:	DATE	SCALE	DWG NO.	SS-C70R-1-S246
Jacky Chen	10/08/14	1 : 1	PART NO.	SS-C70R-1-S246
APPROVED BY:	DATE	SHEET NO.		
Tony Kao	10/08/14	1 of 1		

SIZE A4
VER A1