

CIRCUIT DIAGRAM

P.C.B LAND PATTERN

SS-F36S<sub>x-x</sub>-S246

MODEL NO.	KNOB(X)	SLIDER COLOR :
SS-F36S	2.0 mm	
SS-F36SA	4.0 mm	

Black : B  
White : Blank

SPECIFICATIONS

Rating	0.3A 6V DC
Insulation Resistance	50MΩ Min.
Dielectric Withstanding Voltage	AC 250 V(50Hz)1min
Contact Resistance	100mΩ Max.
Operating Force	230 ± 70gf
Operating Life	10,000 cycles

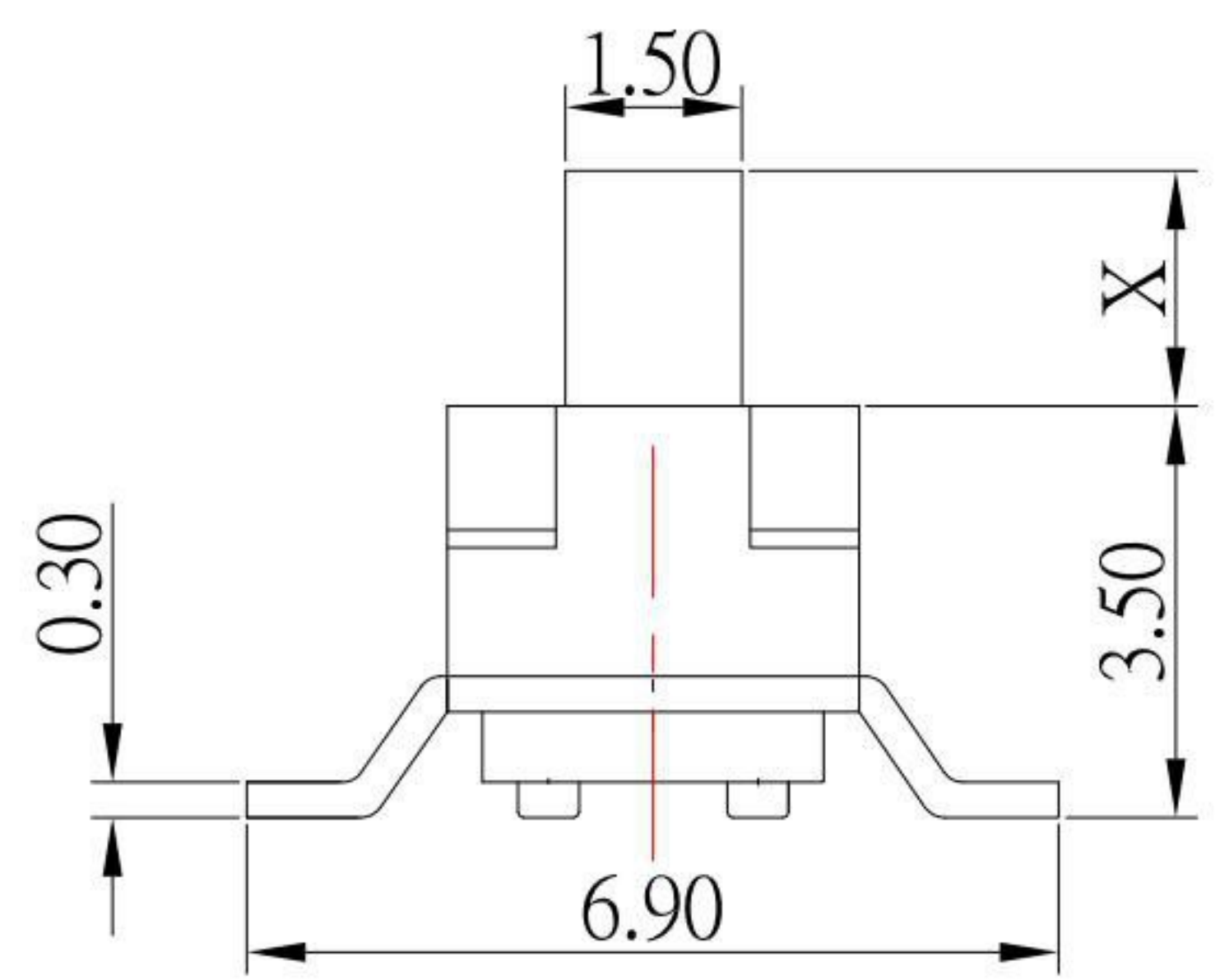
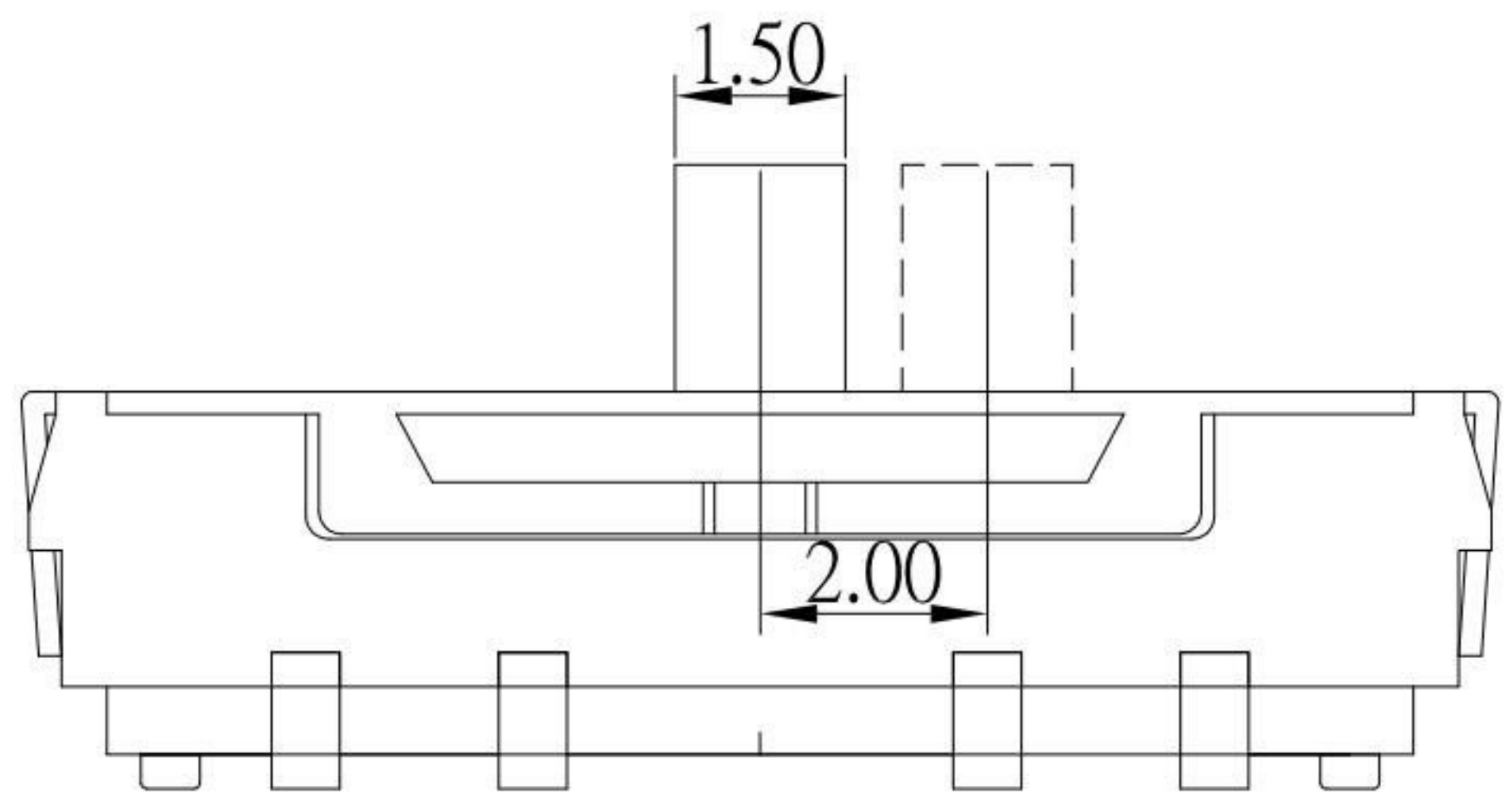

NO.	DESCRIPTION	QTY	MATERIAL	PLATING
E	TERMINAL	8	PHOSPHOR BRONZE	Ag plated
D	CLIP	2	COPPER	Ag plated
C	COVER	1	STAINLESS STEEL	
B	CASE	1	LCP	Black
A	SLIDER	1	PPA	Black

**KSD** 科斯达电子科技有限公司  
SWITCH CONNECTOR KSD ELECTRONIC TECHNOLOGY Co., LTD  
全球 互联零组件制造企业

TOLERANCE UNLESS OTHERWISE STATED:

Up to 5	±0.2
Above 5 ~ 15	±0.3
Above 15 ~ 30	±0.4
Above 30 ~ 50	±0.5
Angle	±0.3°

3RD. ANGEL'S UNITS MM

DRAWN BY:	DATE	MAT'L	TITLE	SWITCH
Jack Lu	06/23/15		MODLE	SLIDE SWITCH
CHECKED BY:	DATE	SCALE	DWG NO.	SS-F36S <sub>x-x</sub> -S246
Jacky Chen	06/23/15	1 : 1	PART NO.	SS-F36S <sub>x-x</sub> -S246
APPROVED BY:	DATE	SHEET NO.	1 of 1	
Tony Kao	06/23/15			

ITEM NO.	DESCRIPTION	DRAWN	DATE
4	新增SLIDER顏色選項	Jack	062315
3	更新料號及SLIDER顏色	Jack	060515
2	更新圖面位置及新增高度選項	Jack	121714
1	更新材質及SPEC	Jack	103113

SIZE A4  
VER R4