

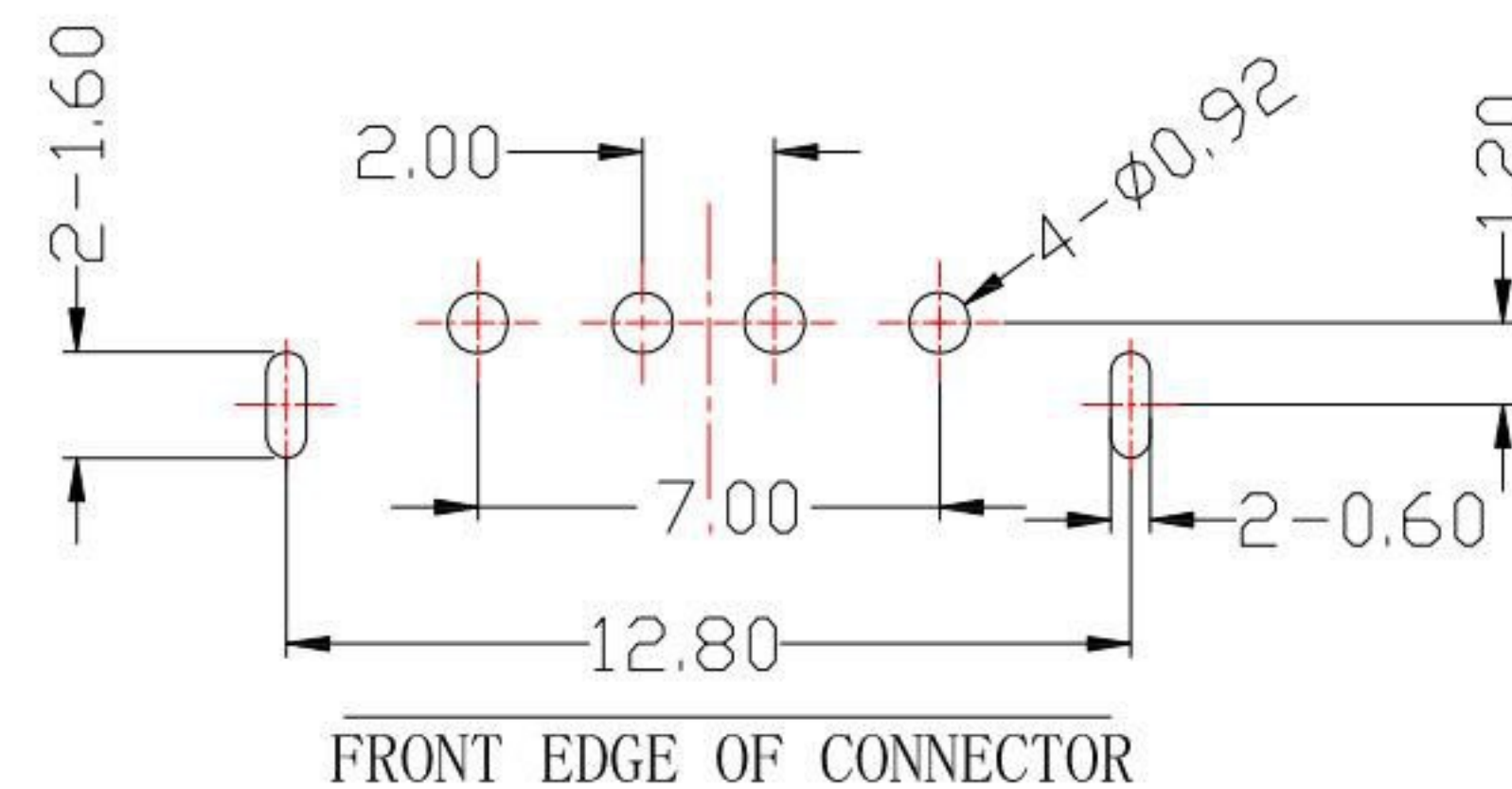

SUA-110H16x-x-S235

Shell Material :	COLOR :
Blank : Brass	Black: B
I : SPCC	White : W

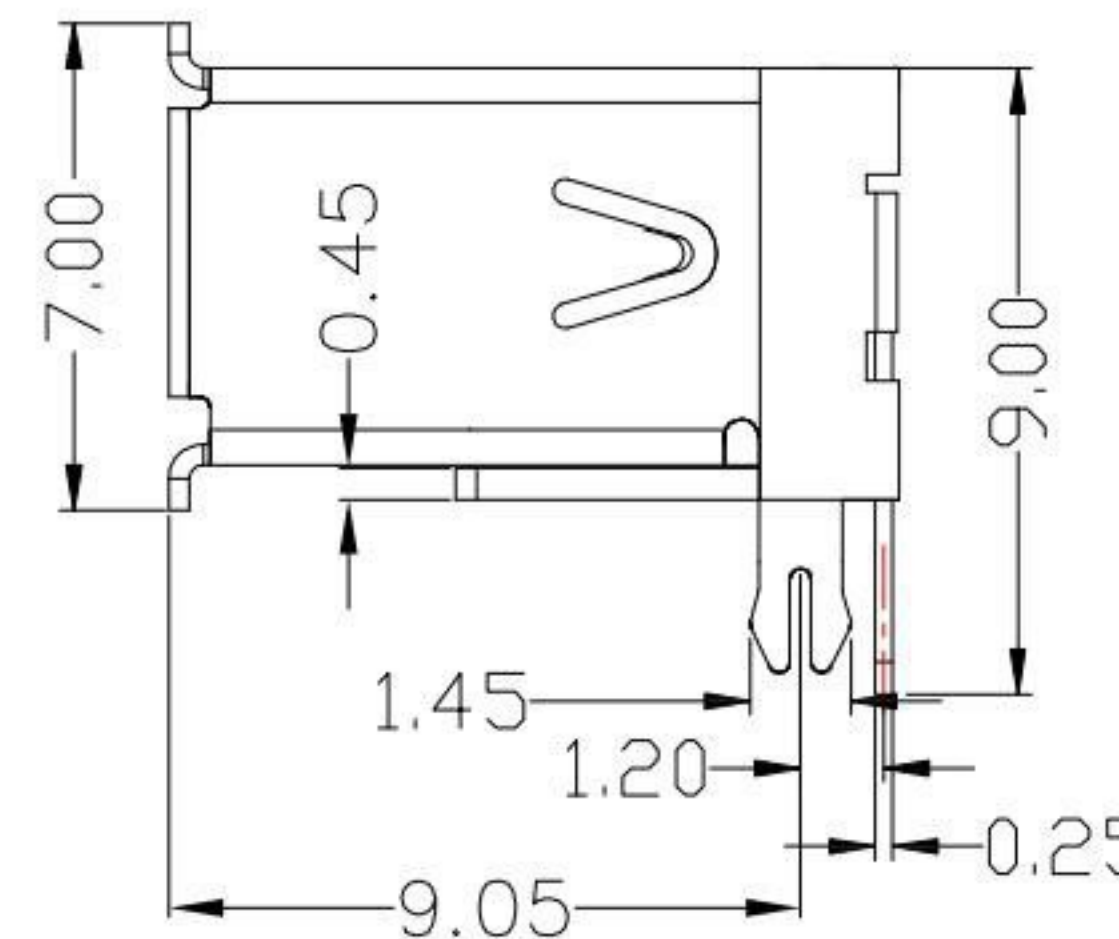
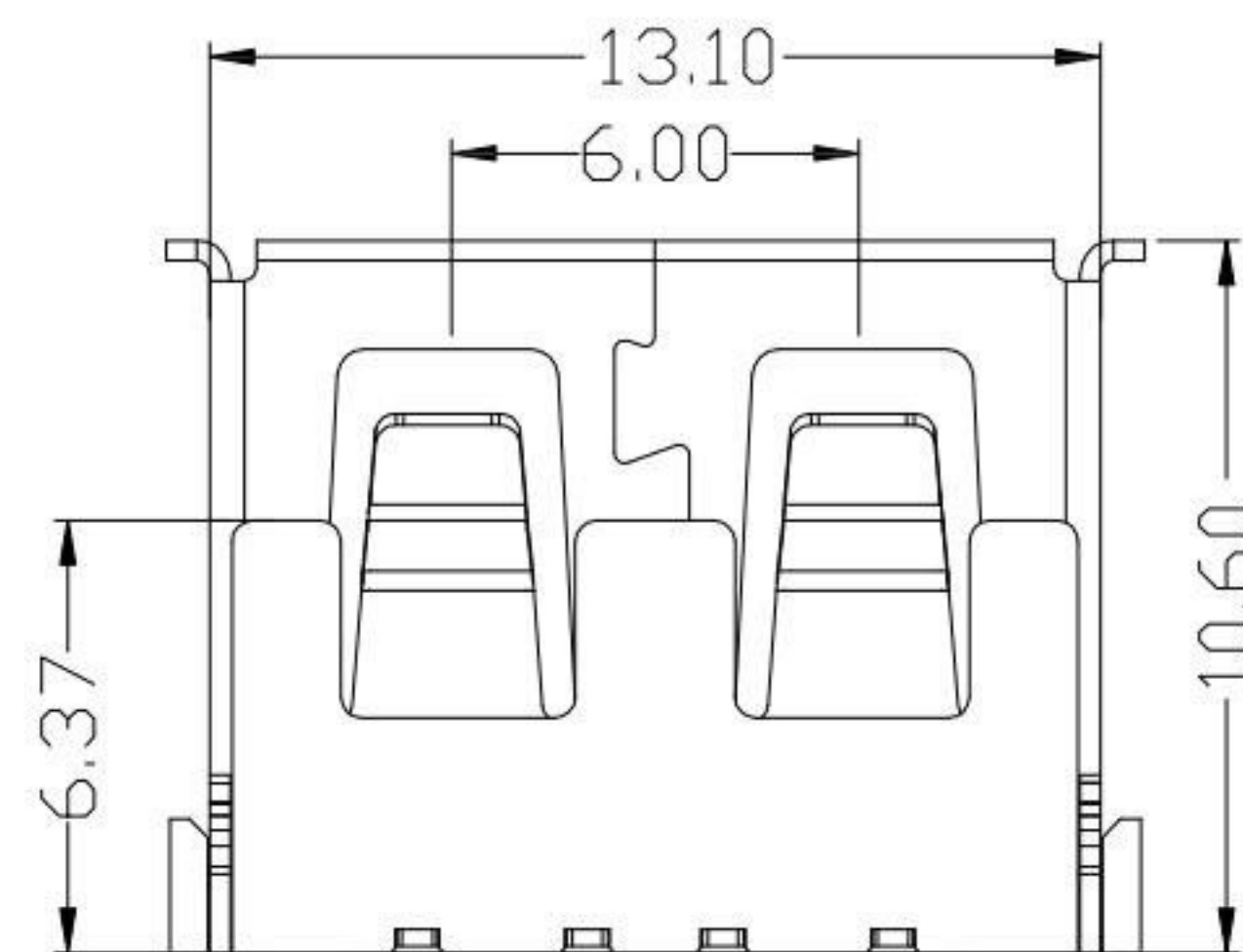
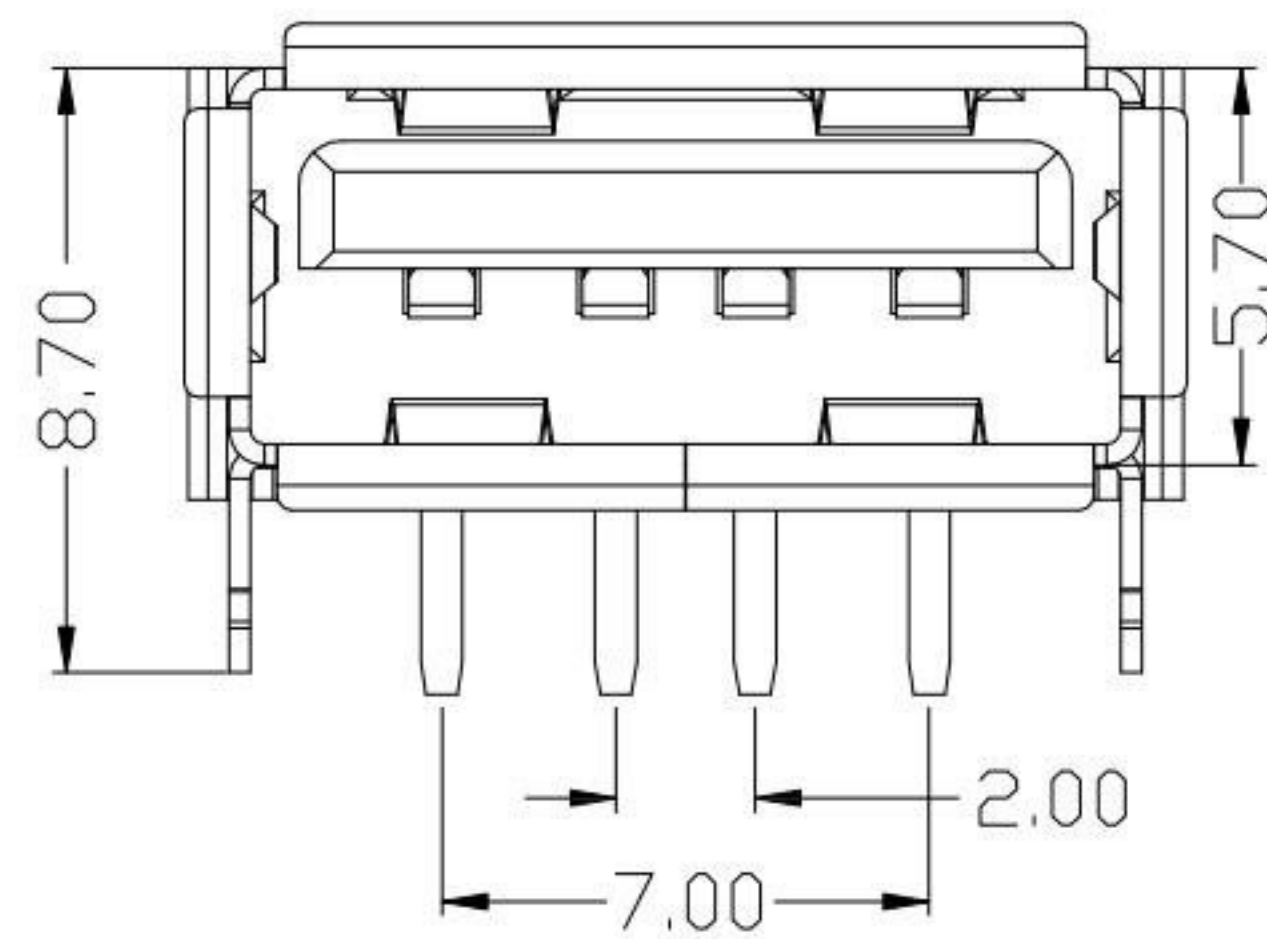
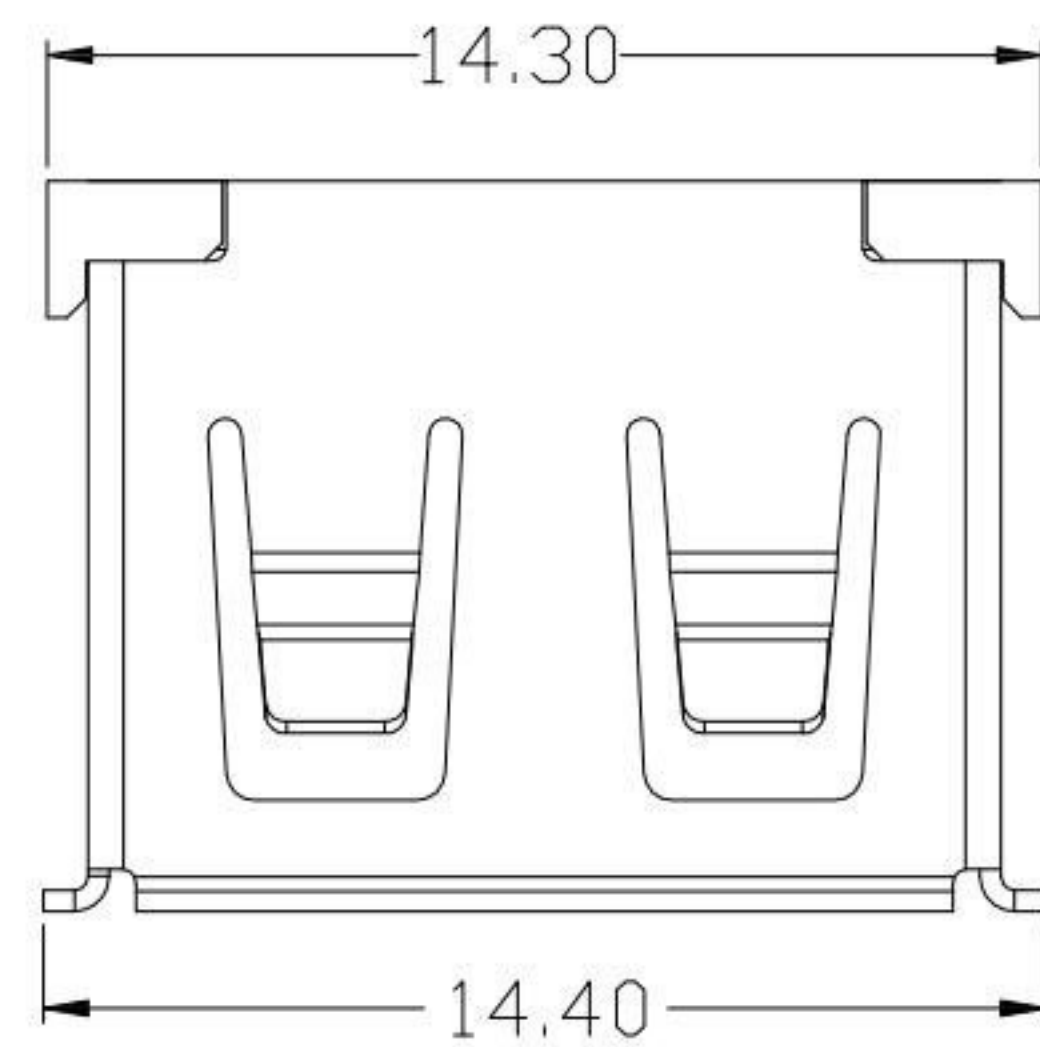

P.C.B LAYOUT MOUNTING PATTERN

SPECIFICATIONS

Electrical:

- Contact Resistance: 30 mΩ Max
- Dielectric Withstanding Voltage: 500 V AC FOR 1 MIN
- Insulation Resistance: 1,000 MΩ Min
- Operating Temperature: -55°C ~ 85°C

Mechanical:

- Connector Mate and Unmate Force
 Mate force: 35N(3.57 kgf) Max
 Unmate force: 10~35N(1.02~3.57 kgf) Min

Material:

- Housing: PBT
- Contact: BRASS
- Shell: BRASS / SPCC

Finish:

- Contact: Plated Gold in Mating Area ;
 Tin Plated on Solder Balls ;
 Nickel under plated overall
- Shell: Nickel under Plated surface layer

KSD 科斯达电子科技有限公司
 SWITCH CONNECTOR KSD ELECTRONIC TECHNOLOGY Co., LTD
 全球 互聯零組件 制造企业

TOLERANCE UNLESS OTHERWISE STATED :	Up to 5 ±0.2	3RD. ANGEL'S	UNITS	MM
	Above 5 ~ 15 ±0.3			
	Above 15 ~ 30 ±0.4			
	Above 30 ~ 50 ±0.5			
	Angle ±0.3°			

DRAWN BY:	DATE
Jack Lu	12/22/17
CHECKED BY:	DATE
Jacky Chen	12/22/17
APPROVED BY:	DATE
Tony Kao	12/22/17

MAT'L	TITLE	CONNECTOR
FINISH	MODLE	USB A/F 短體10.6 後2 腳,H:6.2 , DIP腳
SCALE	DWG NO.	SUA-110H16x-x-S235
SHEET NO.	PART NO.	SUA-110H16x-x-S235
	SIZE	A4
	VER	R1

1	新增外殼材質選項	Jack	122217
ITEM NO.	DESCRIPTION	DRAWN	DATE