

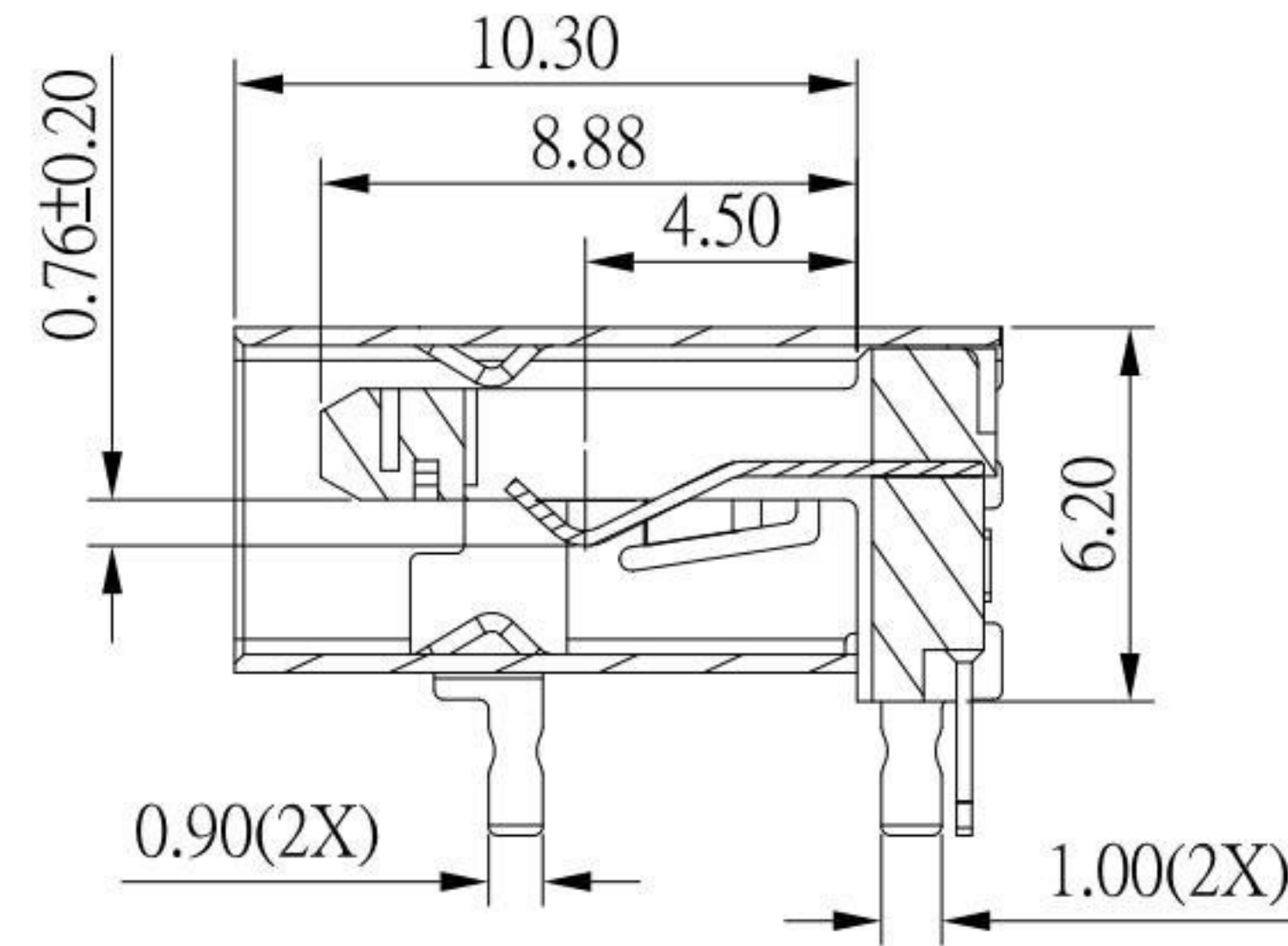

# SUA-110H46-xx-S277

鍍層厚度 : \_\_\_\_\_ Color : \_\_\_\_\_

Blank : 1u"	Black : B
2 : 15u"	Green : GR
3 : 30u"	

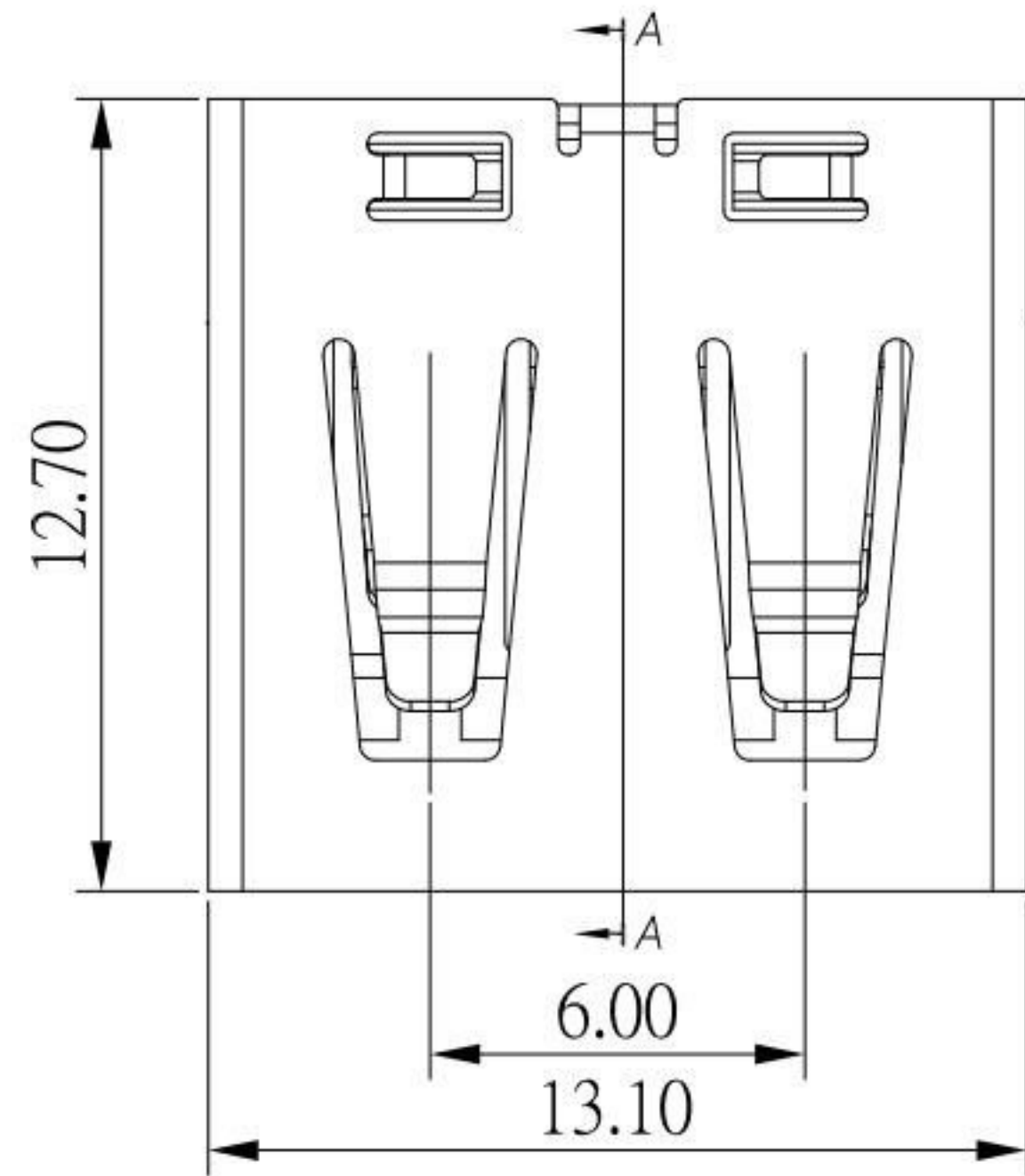

SECTION:A-A

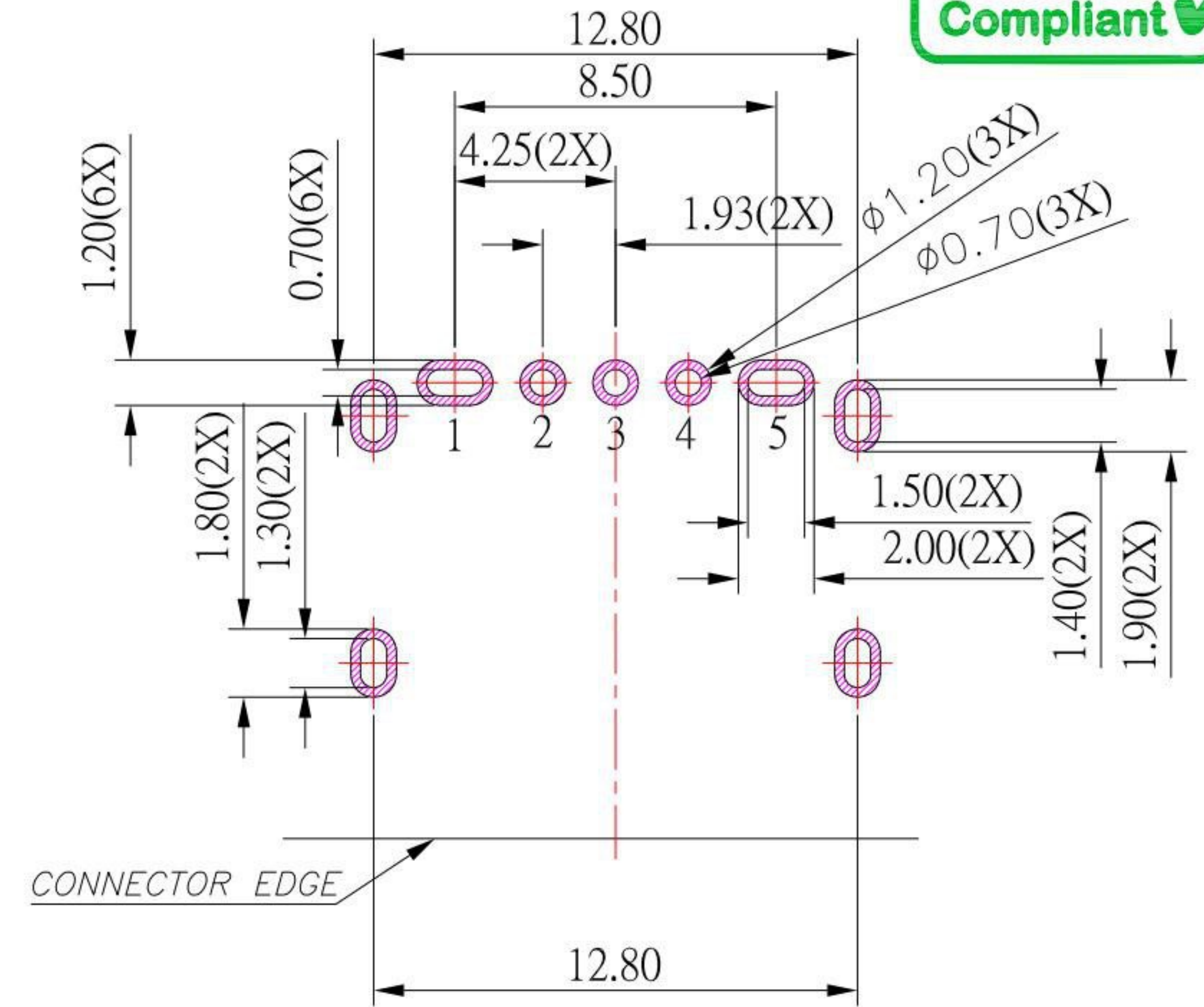

RECOMMENDED PCB LAYOUT

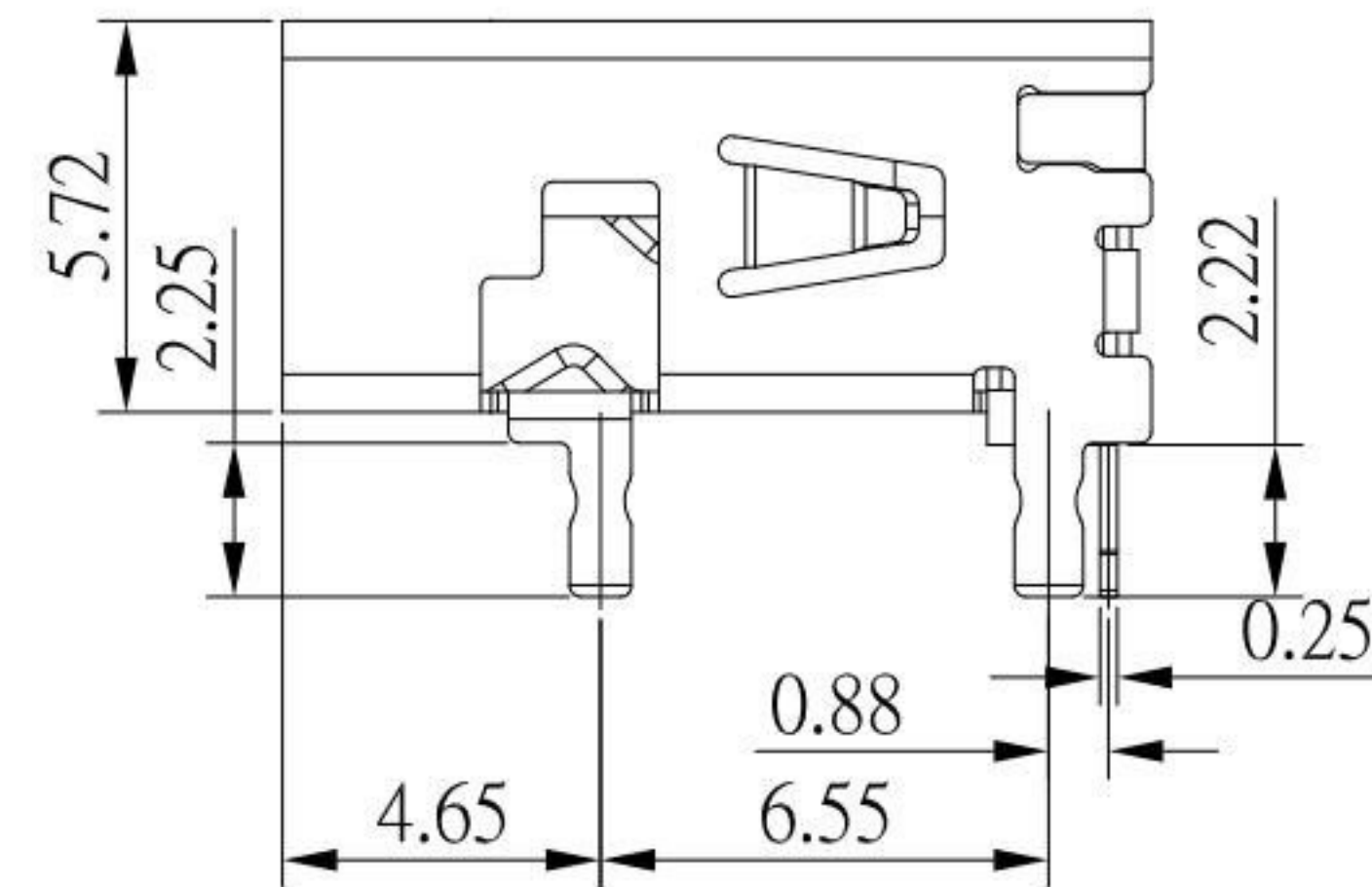
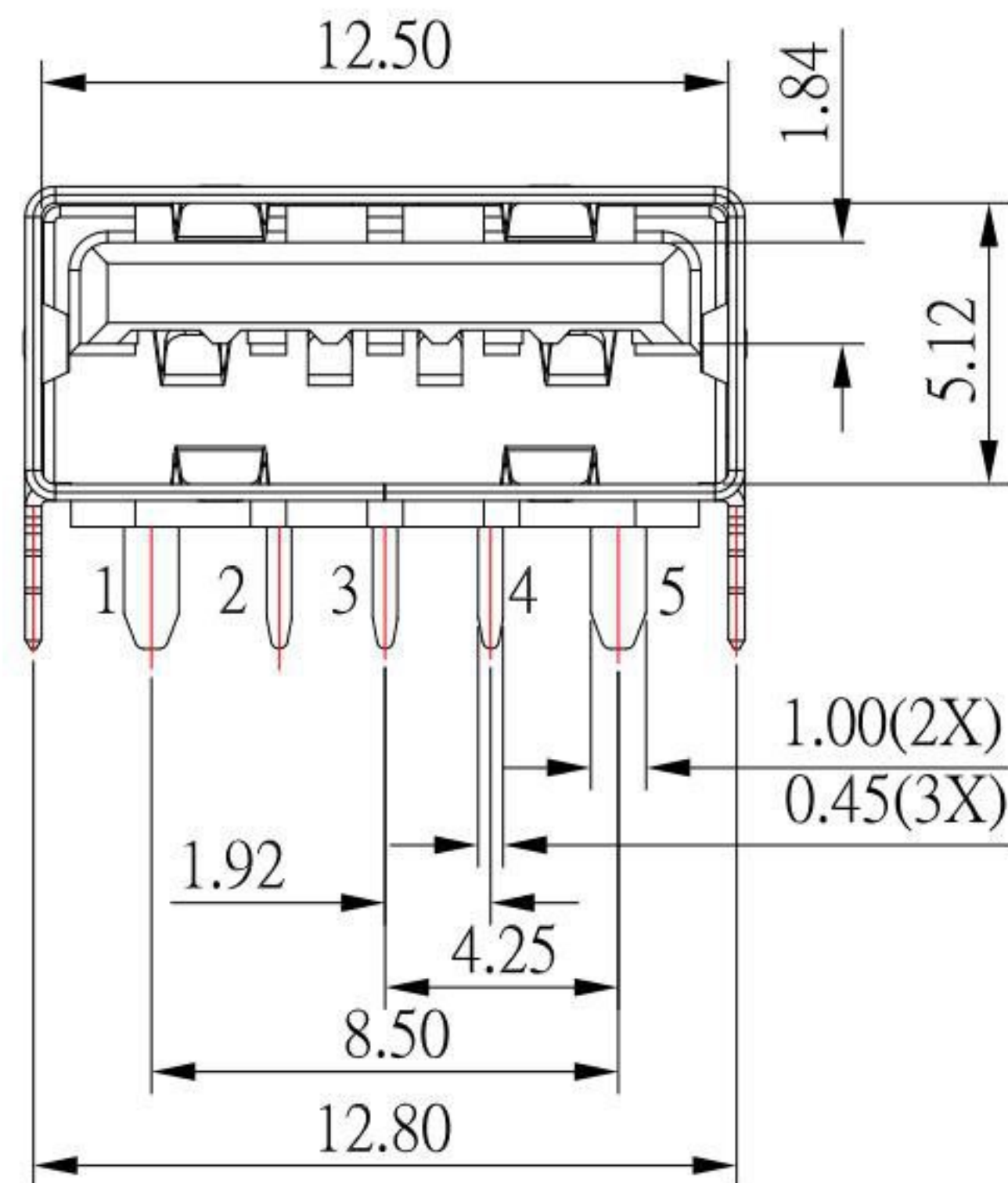

NOTE:

1.MATERIAL:

- 1.1 Housing: PA10T
- 1.2 Contact: Copper Alloy
- 1.3 Shell: SUS

2.Finish:

- 2.1 Contact: Plated Gold in Mating Area ;  
Tin Plated on Solder Balls ;  
Nickel under plated overall
- 2.2 Shell: Nickel under Plated surface layer

3.SPECIFICATION:

- 3.1 Current Rate: 5.0 A(VBUS & GND)
- 3.2 insulator Resistance:100MΩ Min
- 3.3 Dielectric Strength: 100V AC
- 3.4 Contact Resistance: 30mΩ Max
- 3.5 Operation Temperature: -25°C ~ +85°C
- 3.6 Insertion Force: 3.57 kgf Max
- 3.7 Extraction Force: 1.02 kgf Min

**KSD** 科斯达电子科技有限公司  
SWITCH CONNECTOR KSD ELECTRONIC TECHNOLOGY Co., LTD  
全球 互联零组件制造企业

TOLERANCE UNLESS OTHERWISE STATED :  
Up to 5 ±0.2  
Above 5 ~ 15 ±0.3  
Above 15 ~ 30 ±0.4  
Above 30 ~ 50 ±0.5  
Angle ±0.3°

3RD. ANGEL'S

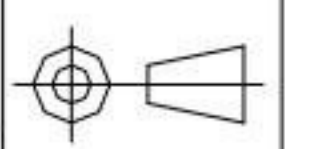

UNITS MM

DRAWN BY:	DATE	MAT'L	TITLE	CONNECTOR
Jack Lu	05/26/20			
CHECKED BY:	DATE	FINISH	MODLE	USB AF 2.0 90度 DIP 5PIN 直脚 無捲邊
Jacky Chen	05/26/20			
APPROVED BY:	DATE	SCALE	DWG NO.	SUA-110H46-xx-S277
Tony Kao	05/26/20	1 : 1		
		SHEET NO.	PART NO.	SUA-110H46-xx-S277
		1 of 1		
				SIZE A4
				VER R4

ITEM NO.	DESCRIPTION	DRAWN	DATE
4	更新圖面	Jack	052620
3	更新為A0版	Jack	101817
2	新增顏色編碼	Jack	100317
1	新增pin編號及圖示	Jack	092217