

P.C.B LAYOUT MOUNTING PATTERN



SPECIFICATIONS

1.MATERIAL:

- a.INSULATOR: PA9T; Color: BLACK
- b.CONTACT: PHOSPHOR BRONZE
- c.BRASS/SHEEL: BRASS

2.PLATING :

a.CONTACT:

- Au PLATING ON THE CONTACT AREA: GOLD FLASH
- TIN PLATING ON THE SOLDER AREA;
- NICKEL UNDERPLATING OVERALL;

b.BRASS/SHELL:NICKEL PLATING OVERALL;

3.ELECTRICAL:

- a.DIELECTRIC WITHSTANDING VOLTAGE: AC 500V
- b.CONTACT RESISTANCE: 30mΩ Max.
- c.INSULATION RESISTANCE: DC 250V / 1,000MΩ MIN;
- d.CONTACT CURRENT RATING: 1Amp. 30V AC;
- e.OPERATING TEMPERATURE: -55°C~ 85°C

4.MECHANICAL:

- a.INSERTION FORCE: 3.57Kg MAX;
- b.WITHDRAWAL FORCE: 1.02Kg MIN;

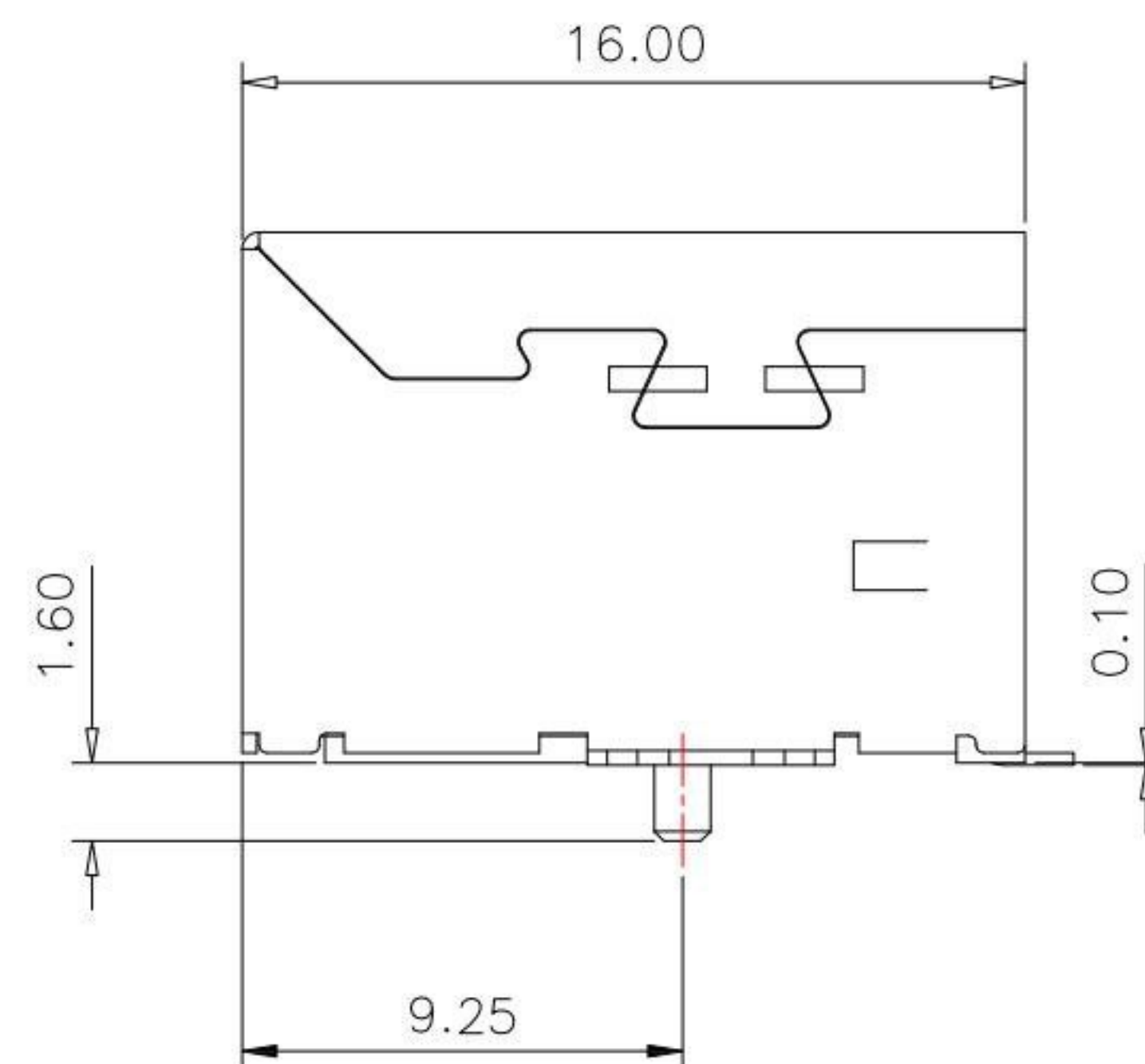
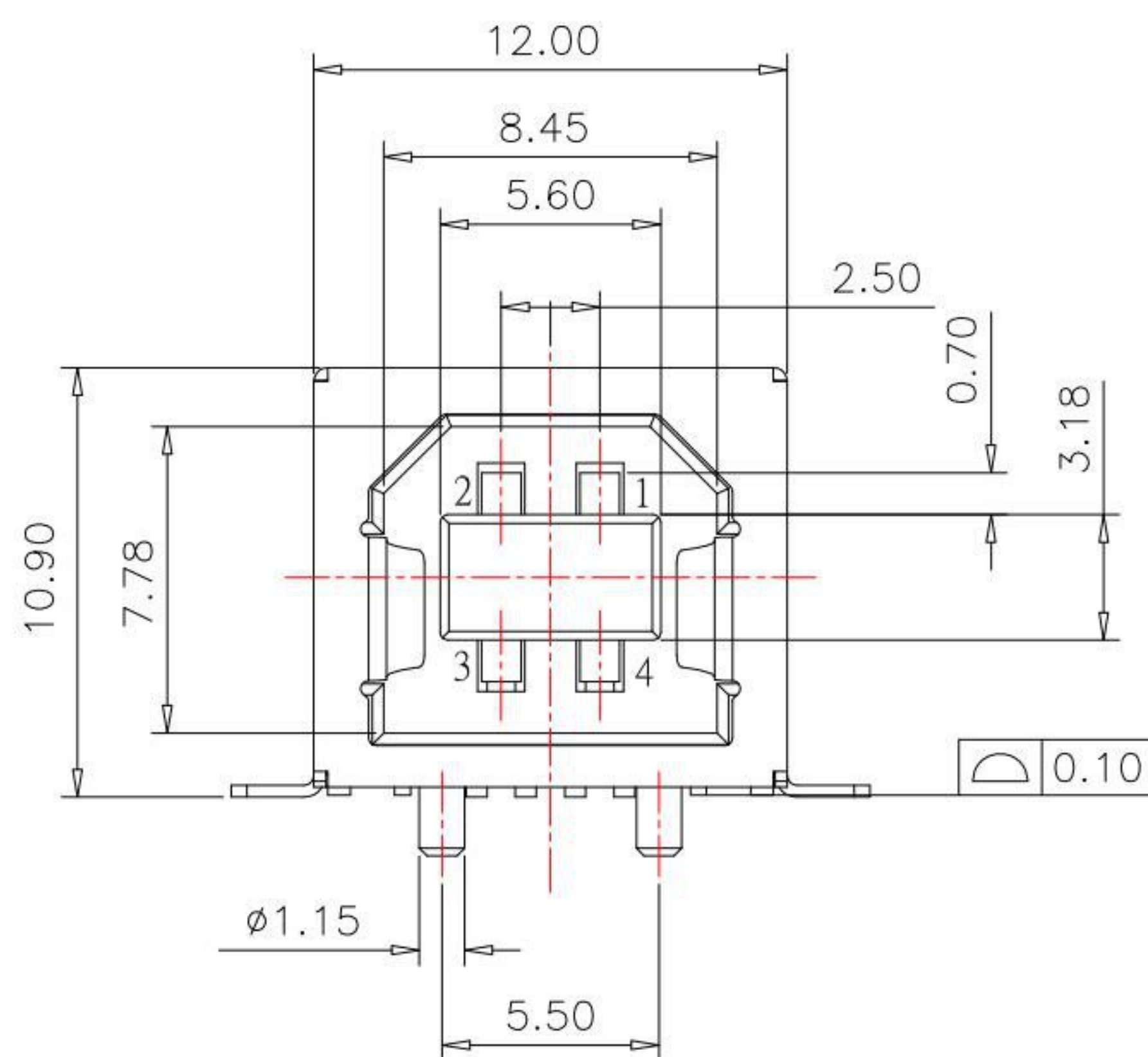

KSD 科斯达电子科技有限公司
 SWITCH CONNECTOR KSD ELECTRONIC TECHNOLOGY Co., LTD
 全球 互 联 零 组 件 制 造 企 业

TOLERANCE UNLESS OTHERWISE STATED:
 Up to 5 ±0.2
 Above 5 ~ 15 ±0.3
 Above 15 ~ 30 ±0.4
 Above 30 ~ 50 ±0.5
 Angle ±0.3°

3RD. ANGEL'S

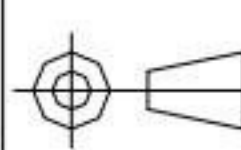

UNITS MM

DRAWN BY: Frank Wu
 DATE: 02/06/12
 CHECKED BY: Jacky Chen
 DATE: 02/06/12
 APPROVED BY: Tony Kao
 DATE: 02/06/12

MAT'L		TITLE	CONNECTOR
FINISH		MODLE	USB BF SMD TYPE
SCALE	1:1	DWG NO.	SUB-110S-B-S165
SHEET NO.	1 of 1	PART NO.	SUB-110S-B-S165

SIZE A4
 VER B

ITEM NO.	DESCRIPTION	DRAWN	DATE
----------	-------------	-------	------