

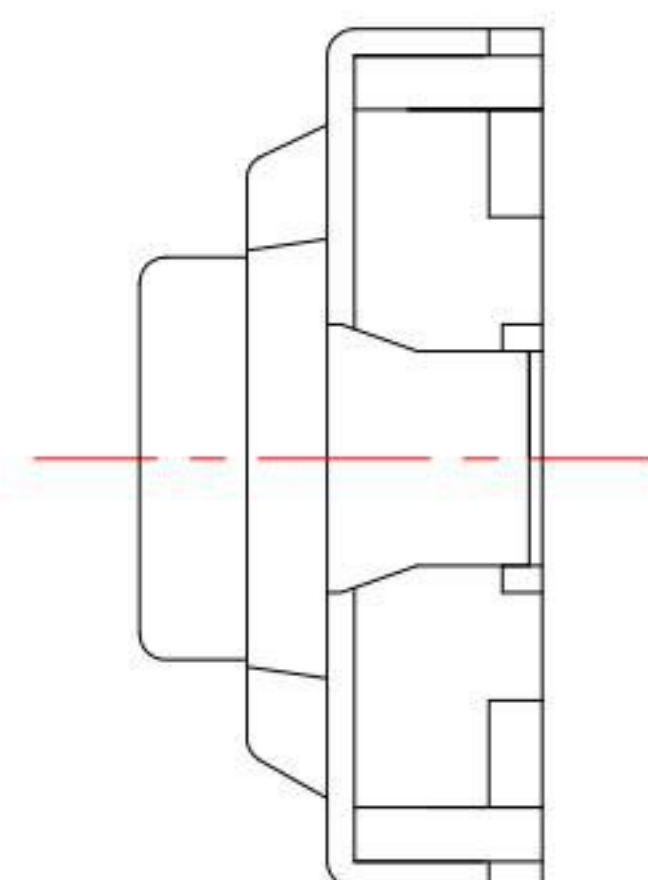

PRODUCT IMAGE

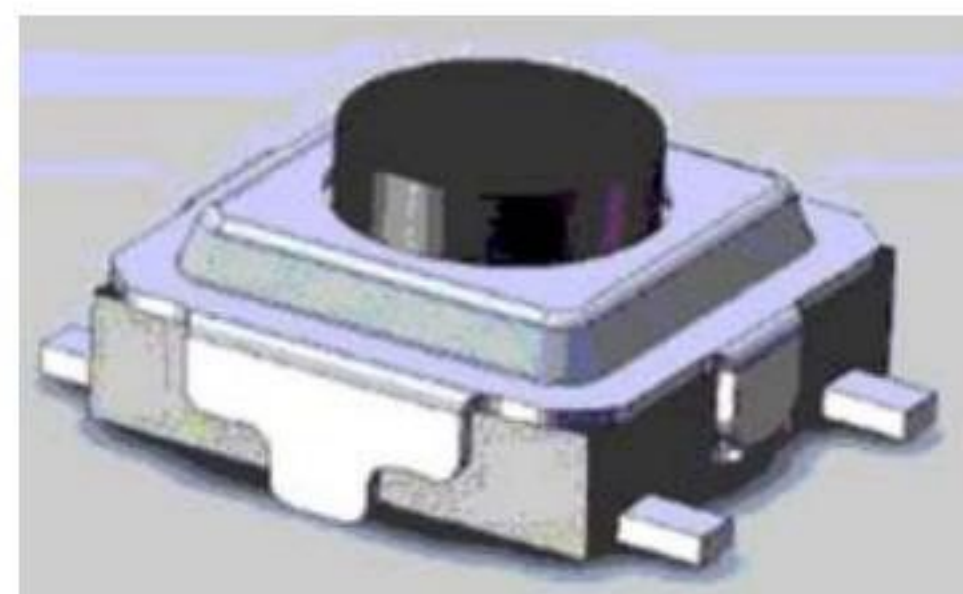

P.C.B MOUNTING MOUNTING PATTERN

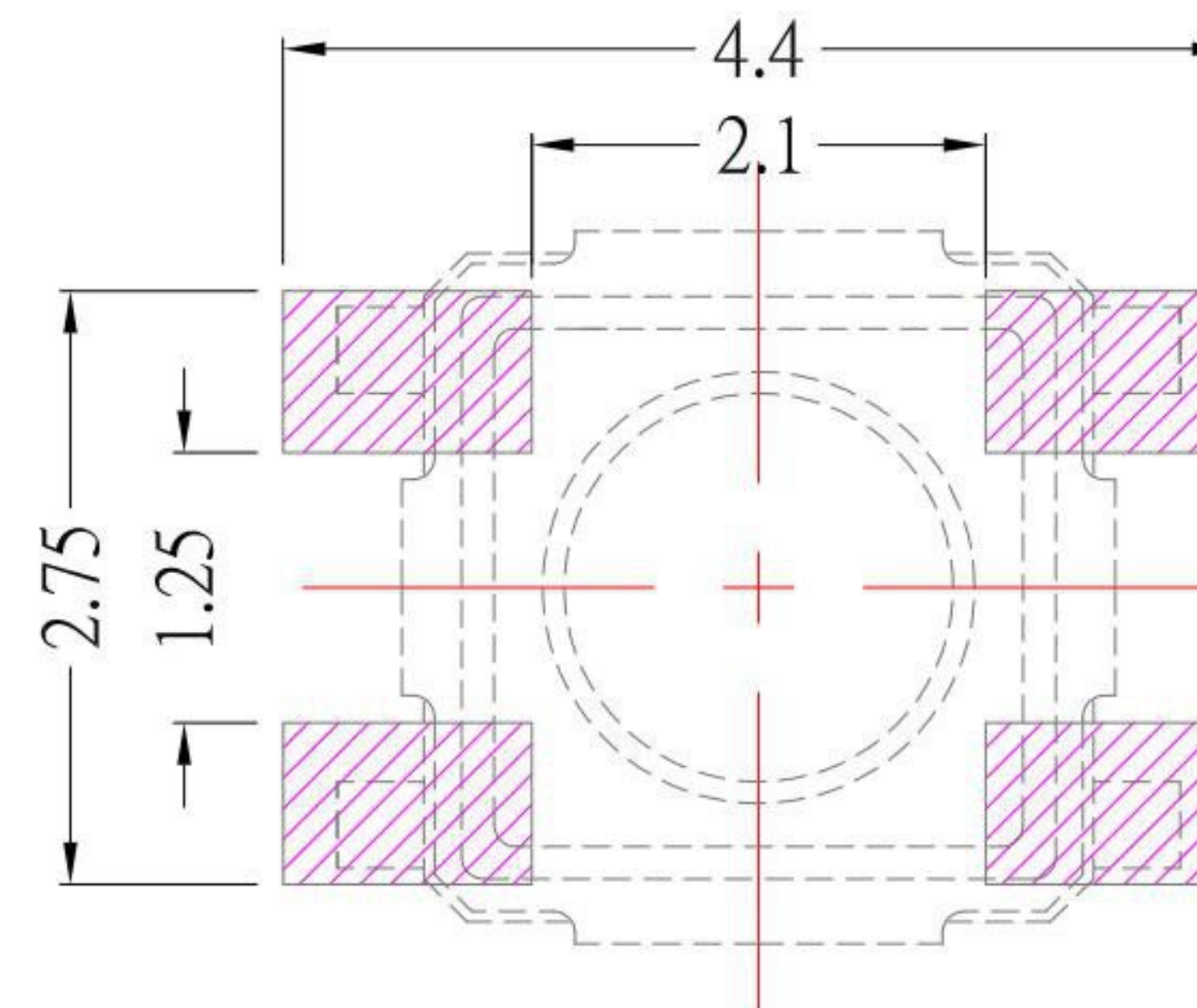

NO	MODEL	HEIGHT(L)	COLOR
1	TS-307KF	1.5 mm	WHITE
2	TS-307KFA	2.0 mm	BLACK

DIMENSIONS

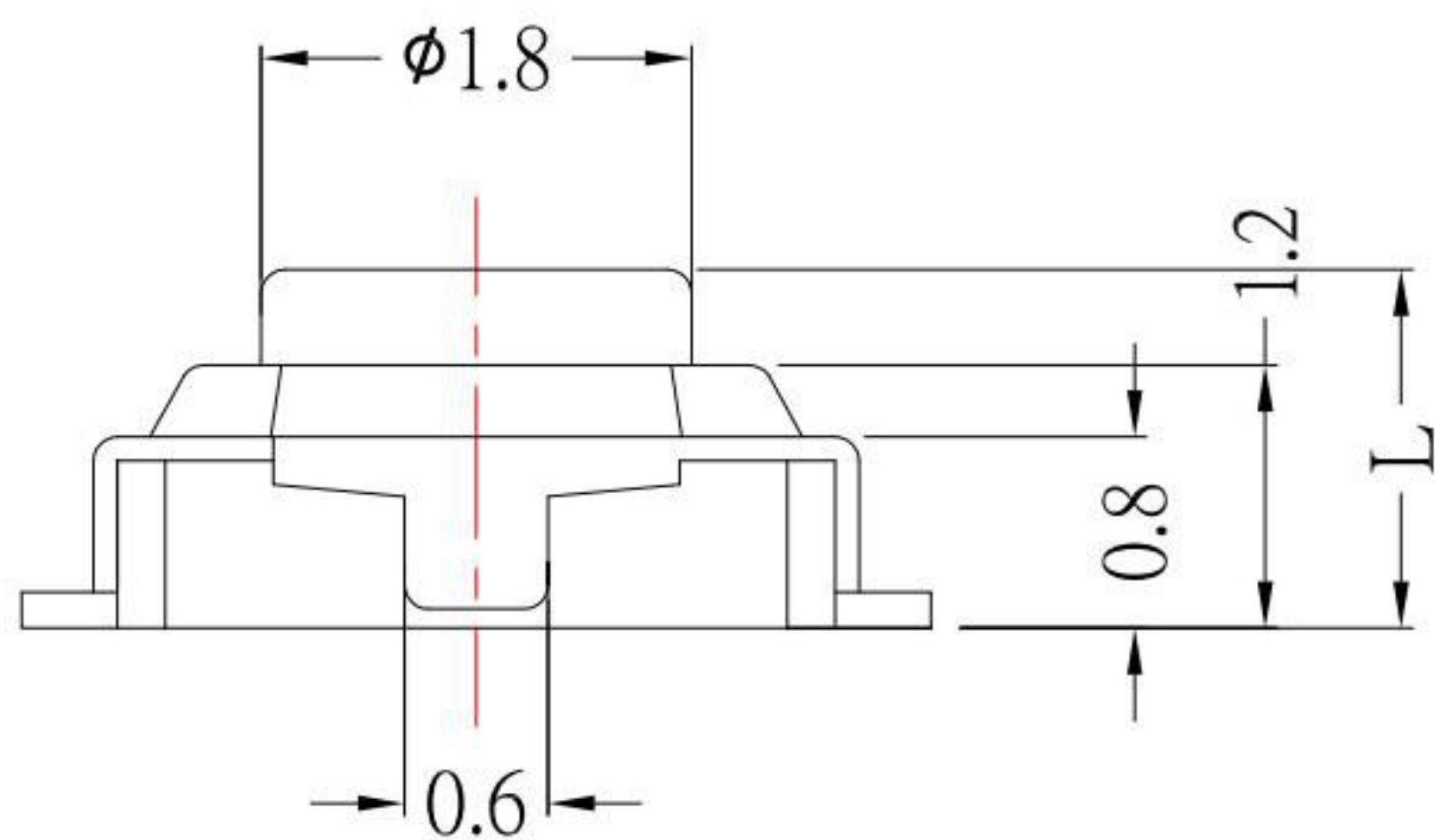
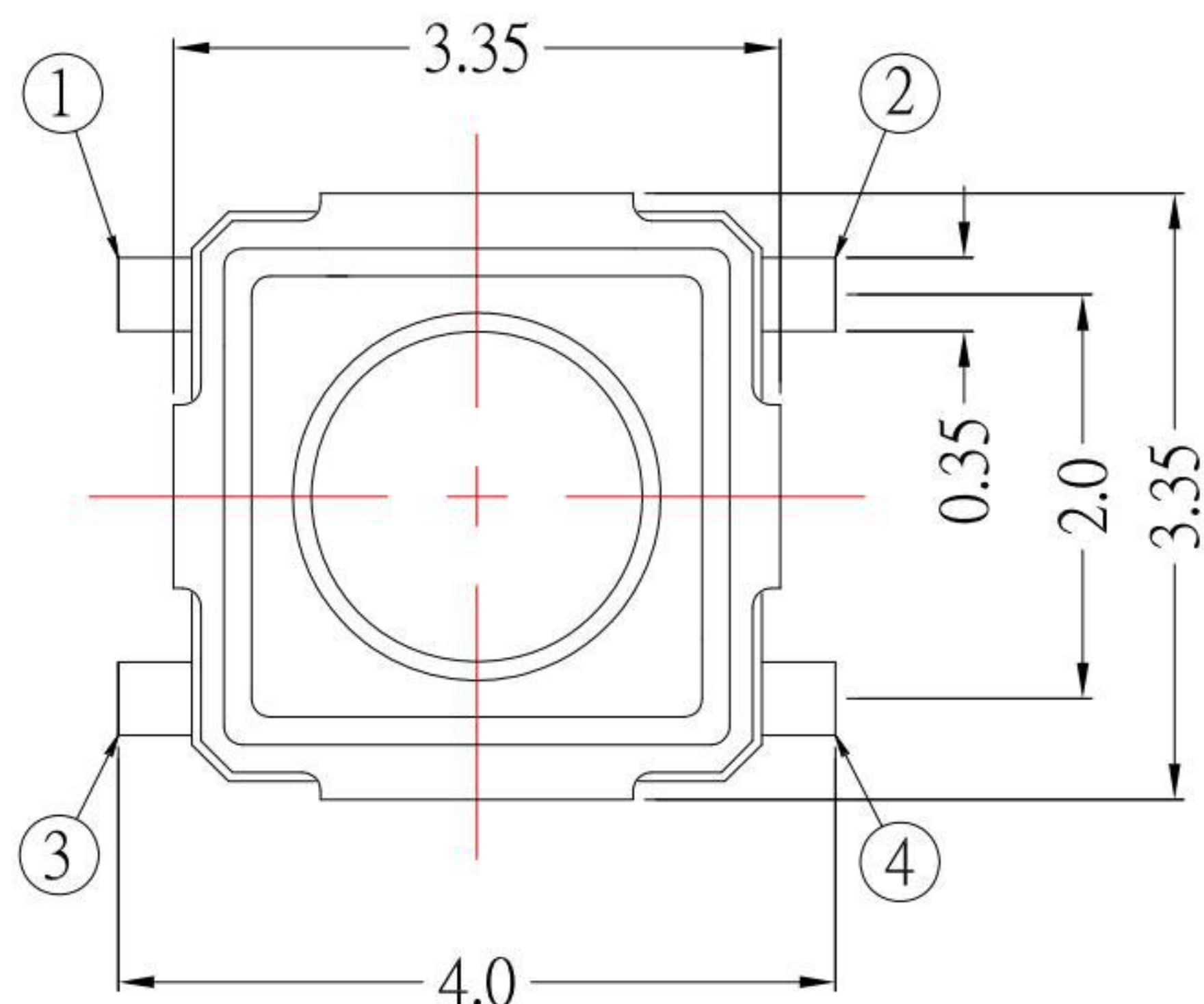

CIRCUIT DIAGRAM

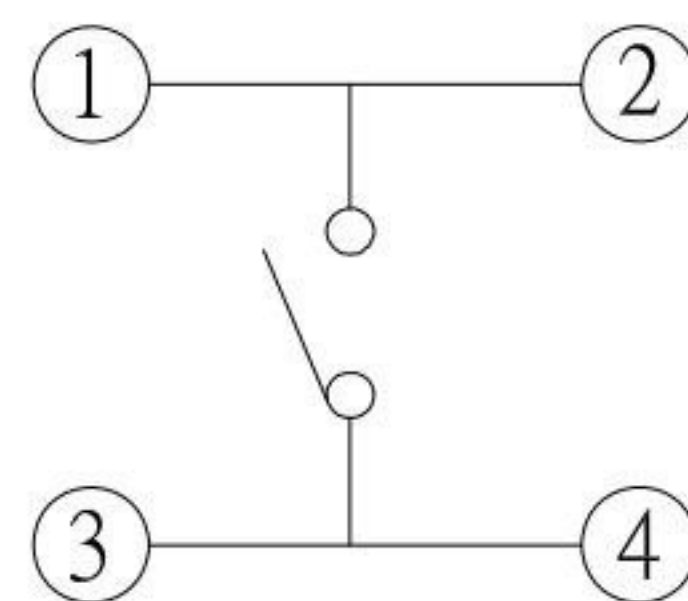

SPECIFICATIONS

Rating	DC 12V / 50mA Max.
Circuit	1C-1P
Operating Force	1 130 ± 30gf 2 160 ± 50gf 3 250 ± 50gf
Contact Resistance	100mΩ Max.
Travel	0.20±0.1mm
Operating Life	100,000 cycles Min.

5	更新高度顏色選項	Jack	070915
4	更新為A0版	Jack	080513
3	更新高度選項料號	Jack	042513
2	新增"L"高度選項	Jack	012113
1	※ WB : Knob:white / Case: Black Color	FrankWu	022112
ITEM NO.	DESCRIPTION	DRAWN	DATE

KSD 科斯达电子科技有限公司
 SWITCH CONNECTOR KSD ELECTRONIC TECHNOLOGY Co., LTD
 全球 互聯零組件 制造企业

TOLERANCE UNLESS OTHERWISE STATED:
 Up to 5 ±0.2
 Above 5 ~ 15 ±0.3
 Above 15 ~ 30 ±0.4
 Above 30 ~ 50 ±0.5
 Angle ±0.3

3RD. ANGEL'S

UNITS MM

DRAWN BY:	DATE	MAT'L	TITLE	SWITCH
Jack Lu	07/09/15			
CHECKED BY:	DATE	FINISH	MODLE	TACT SWITCH
Jacky Chen	07/09/15			
APPROVED BY:	DATE	SCALE	DWG NO.	TS-307KF-x-S126
Tony Kao	07/09/15	1 : 1		
SHEET NO.	1 of 1	PART NO.	TS-307KF-x-S126	
				SIZE A4
				VER A1