

PCB LAYOUT

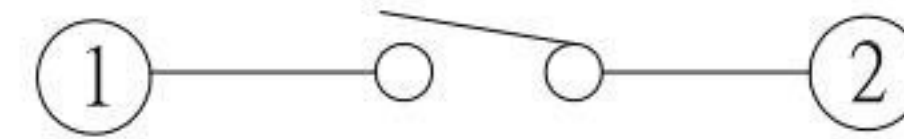

CIRCUIT DIAGRAM

HEIGHT

MODEL NO.	H(mm)
TS-A09V	3.8
TS-A09VA	4.3
TS-A09VB	4.8
TS-A09VC	5.0
TS-A09VD	6.0
TS-A09VE	7.0

SPECIFICATIONS

Rating	DC 12V 0.05A.	
Insulation Resistance	50 MΩ Min.	
Contact Resistance	100 mΩ Max.	
Operating Force	2 160 ± 50gf	3 260 ± 50gf
Operating Life (cycles)	80,000	
Travel	0.15 ± 0.1mm	

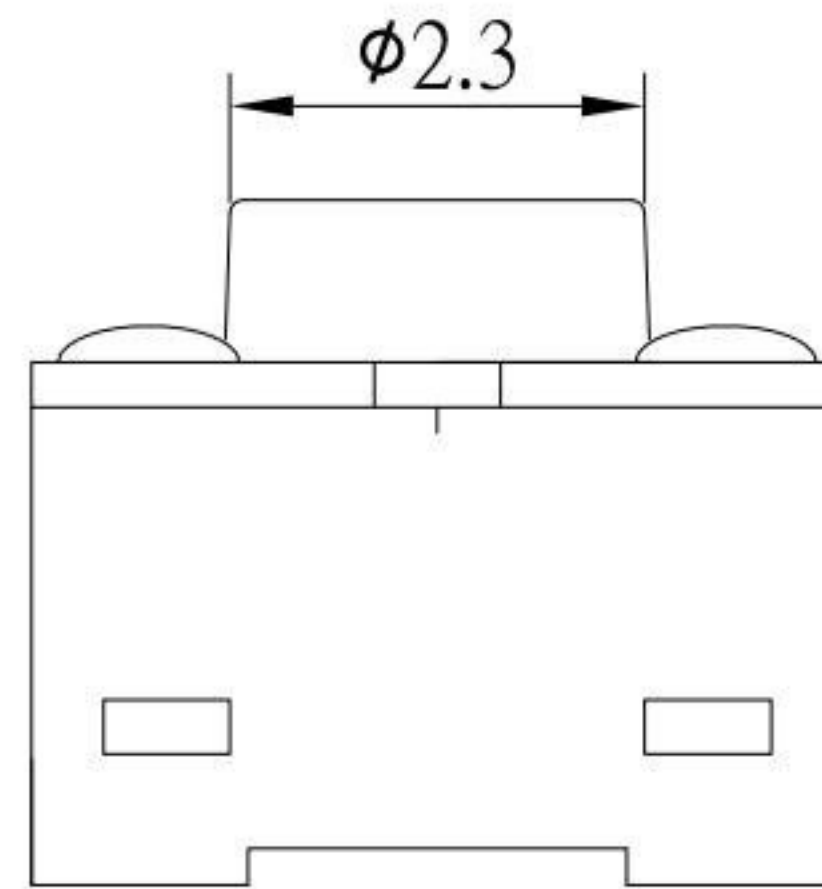
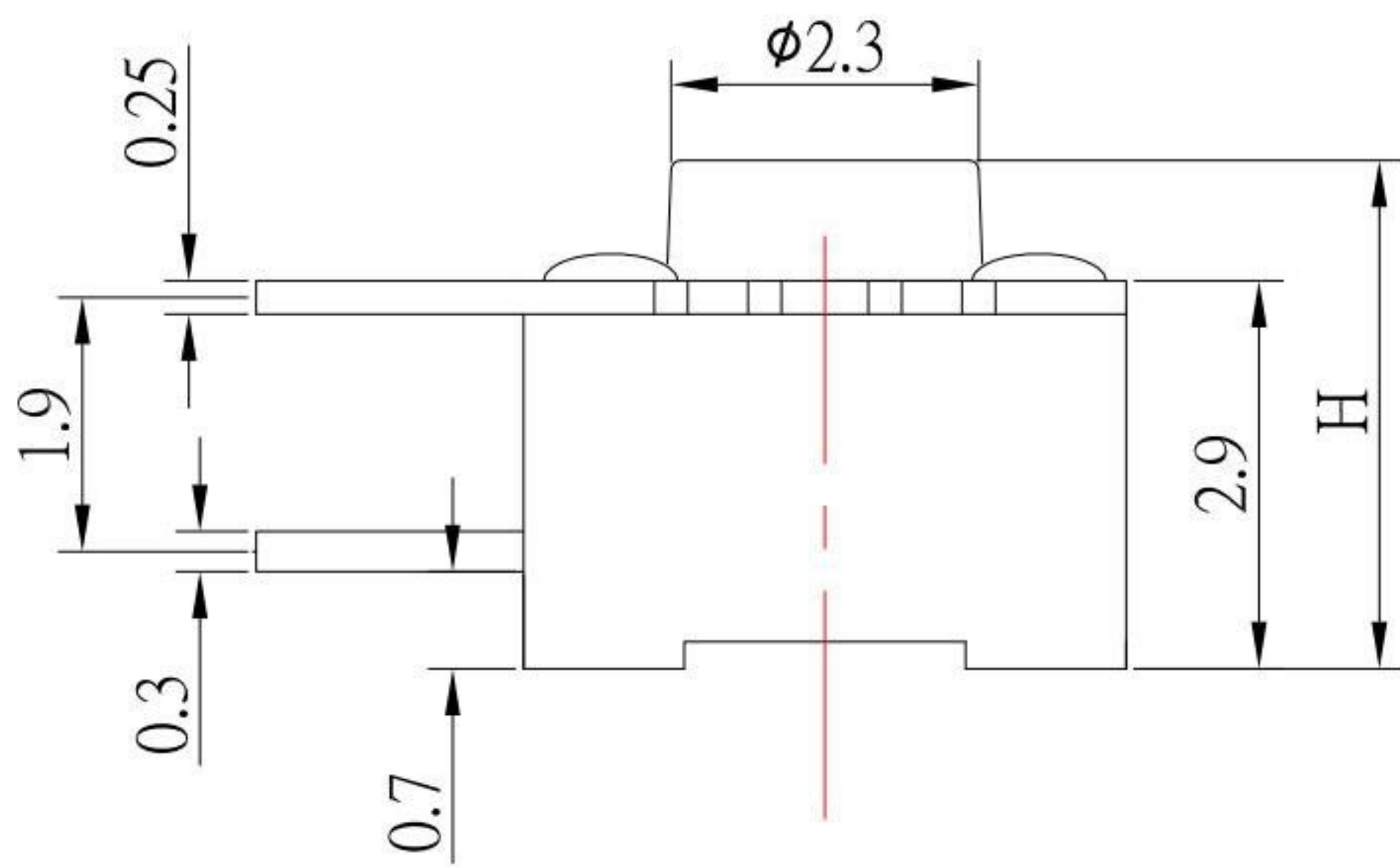

NO.	DESCRIPTION	QTY	MATERIAL	PLATING
E	TERMINAL	2	BRASS	Ag plated
D	CONTACT	1	SUS	Ag plated
C	COVER	1	BRASS	Ag plated
B	BASE	1	PPA	Black
A	STEM	1	PA46	Black

**KSD** 科斯达电子科技有限公司  
 SWITCH CONNECTOR KSD ELECTRONIC TECHNOLOGY Co., LTD  
 全球 互聯零組件製造企業

TOLERANCE UNLESS OTHERWISE STATED:  
 Up to 5 ±0.2  
 Above 5 ~ 15 ±0.3  
 Above 15 ~ 30 ±0.4  
 Above 30 ~ 50 ±0.5  
 Angle ±0.3

3RD. ANGEL'S

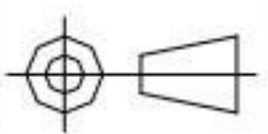

UNITS MM

DRAWN BY:	DATE	MAT'L	TITLE	SWITCH
Jack Lu	02/10/15		MODLE	TACT SWITCH
CHECKED BY:	DATE	FINISH	DWG NO.	TS-A09Vx-x-S246
Jacky Chen	02/10/15		PART NO.	TS-A09Vx-x-S246
APPROVED BY:	DATE	SCALE	1 : 1	
Tony Kao	02/10/15	SHEET NO.	1 of 1	

ITEM NO.	DESCRIPTION	DRAWN	DATE
2	新增尺寸及PIN腳標示	Jack	021015
1	新增Travel	Jack	103114

SIZE A4  
VER R2