

IP67

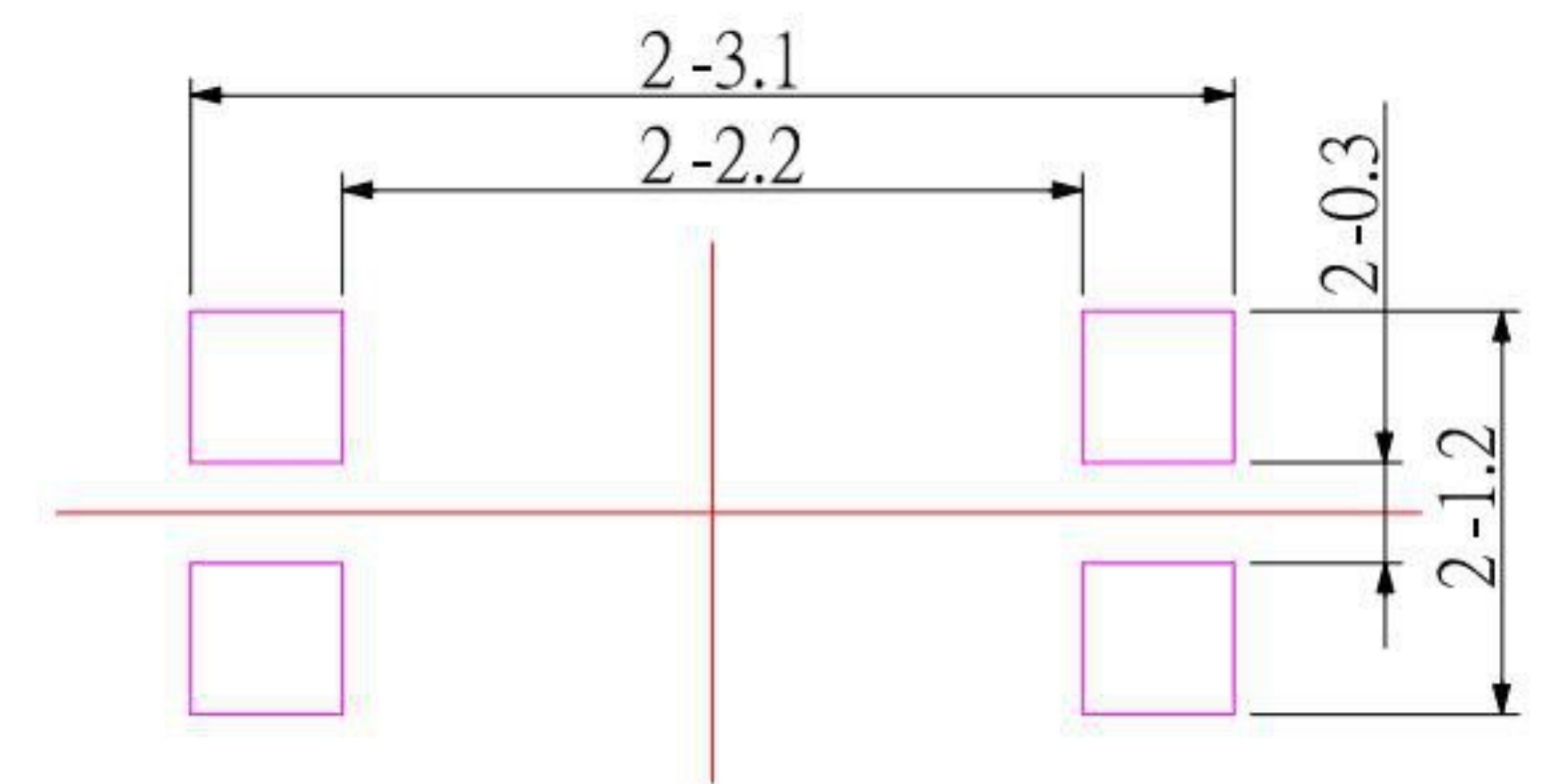

PCB LAYOUT

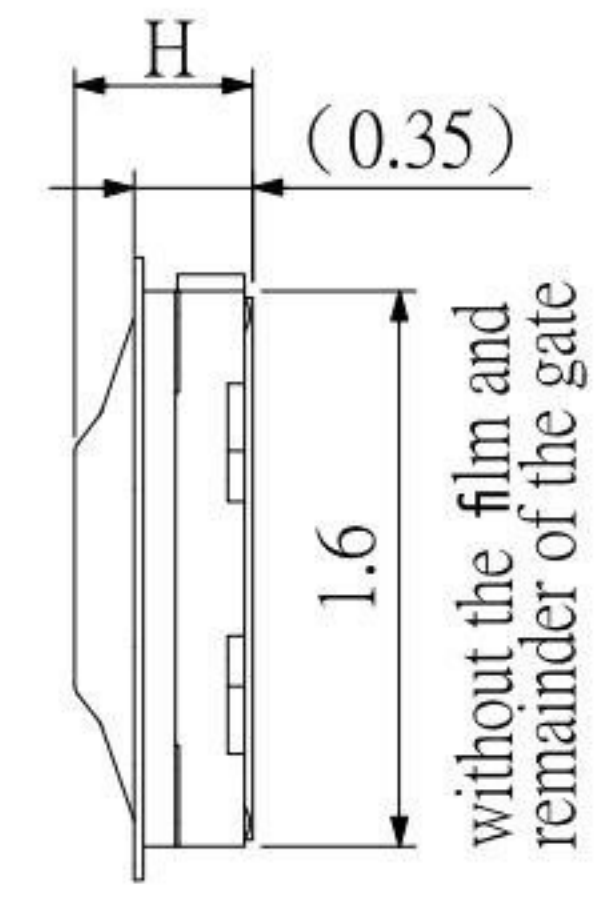
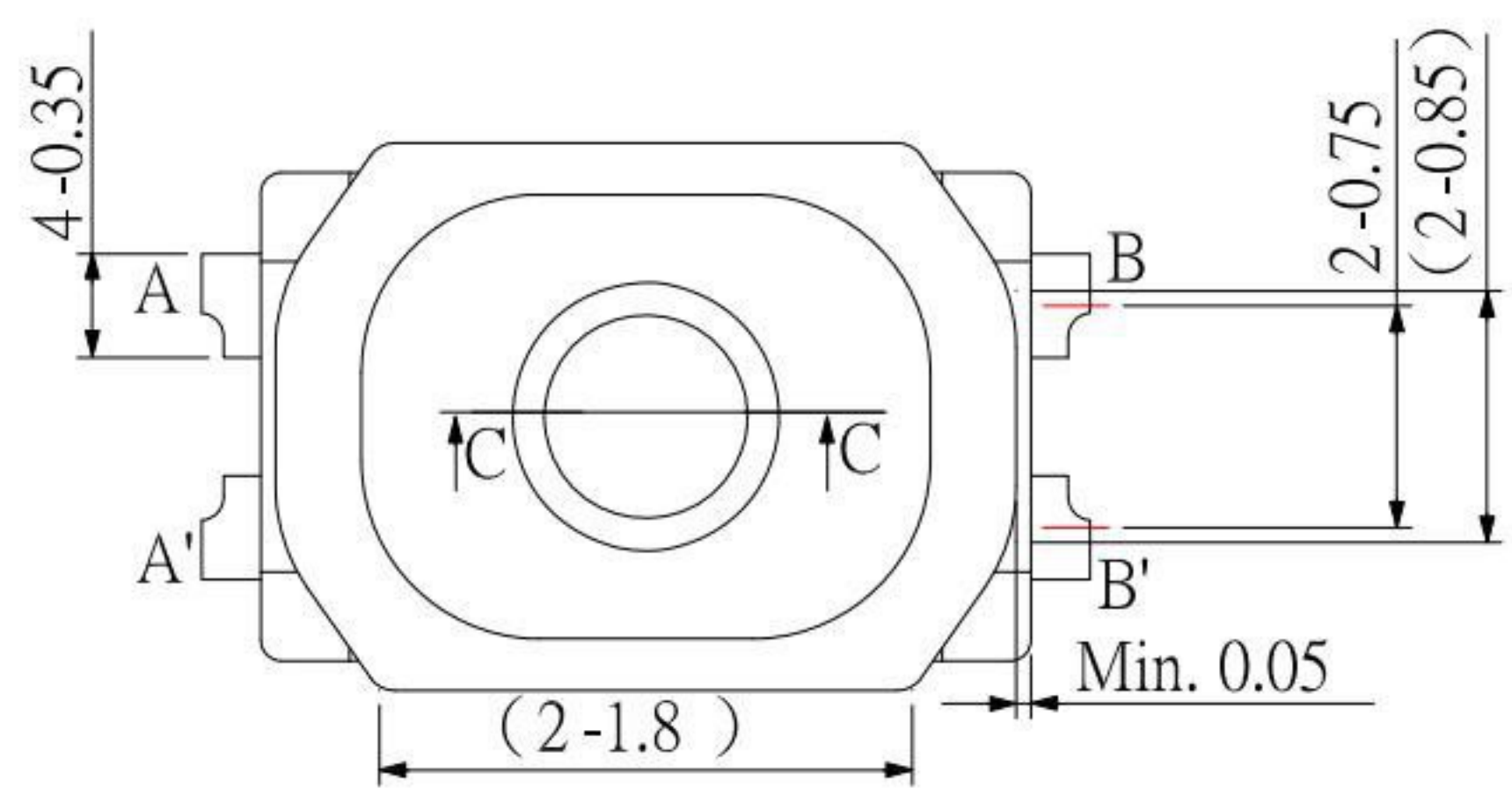
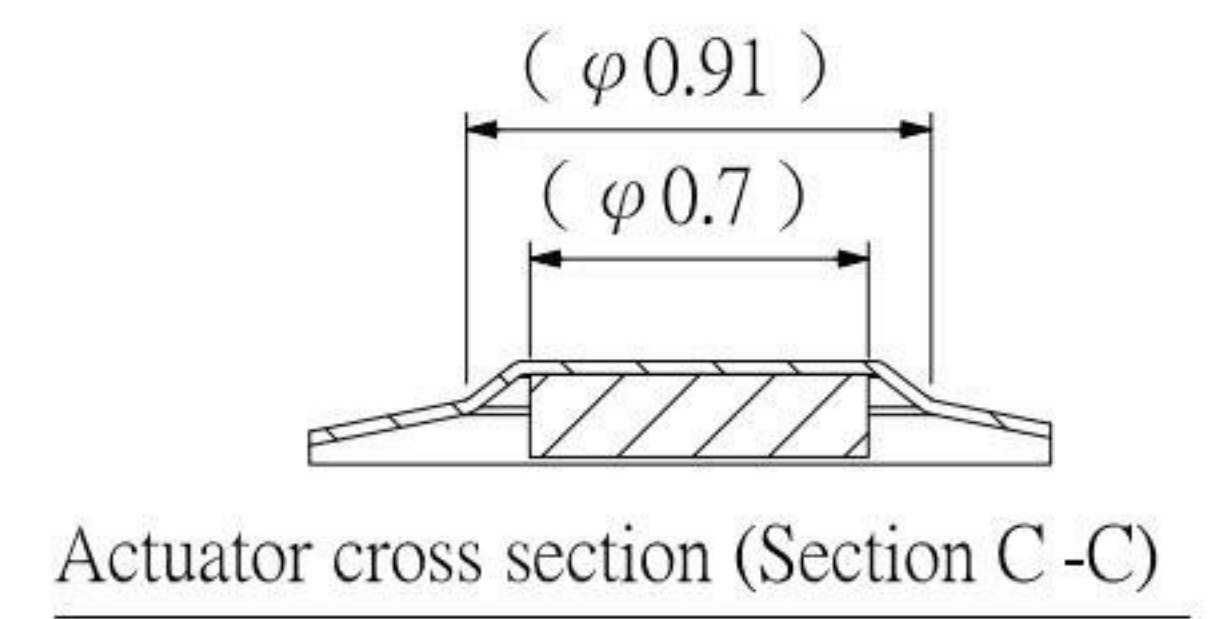
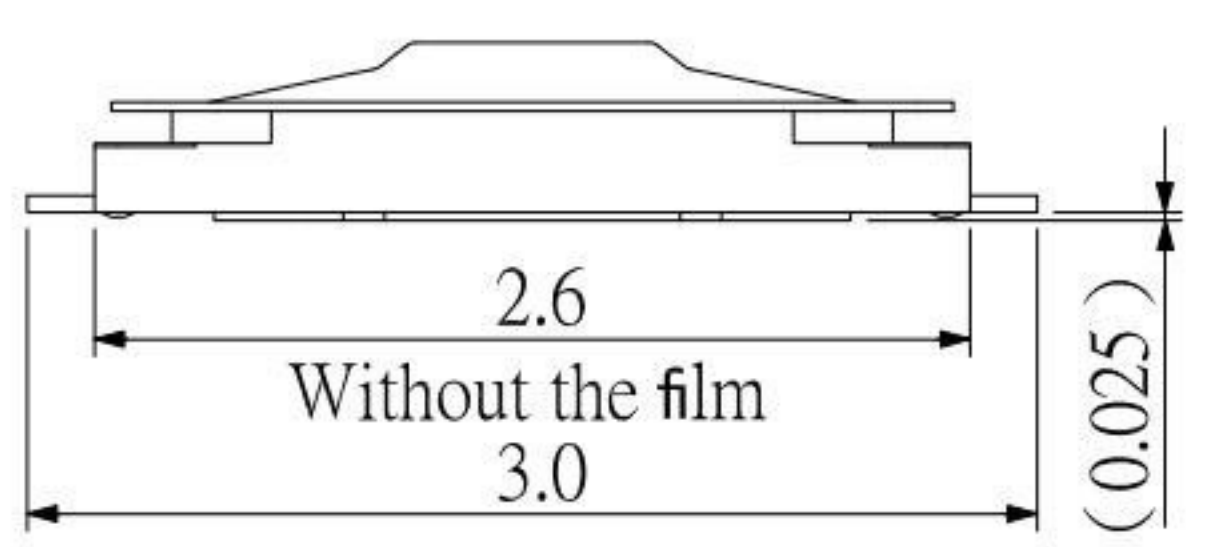

Actuator cross section (Section C-C)

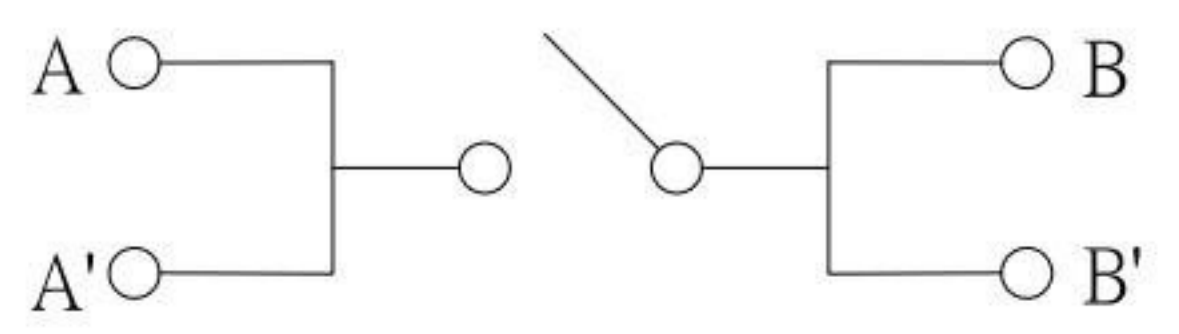
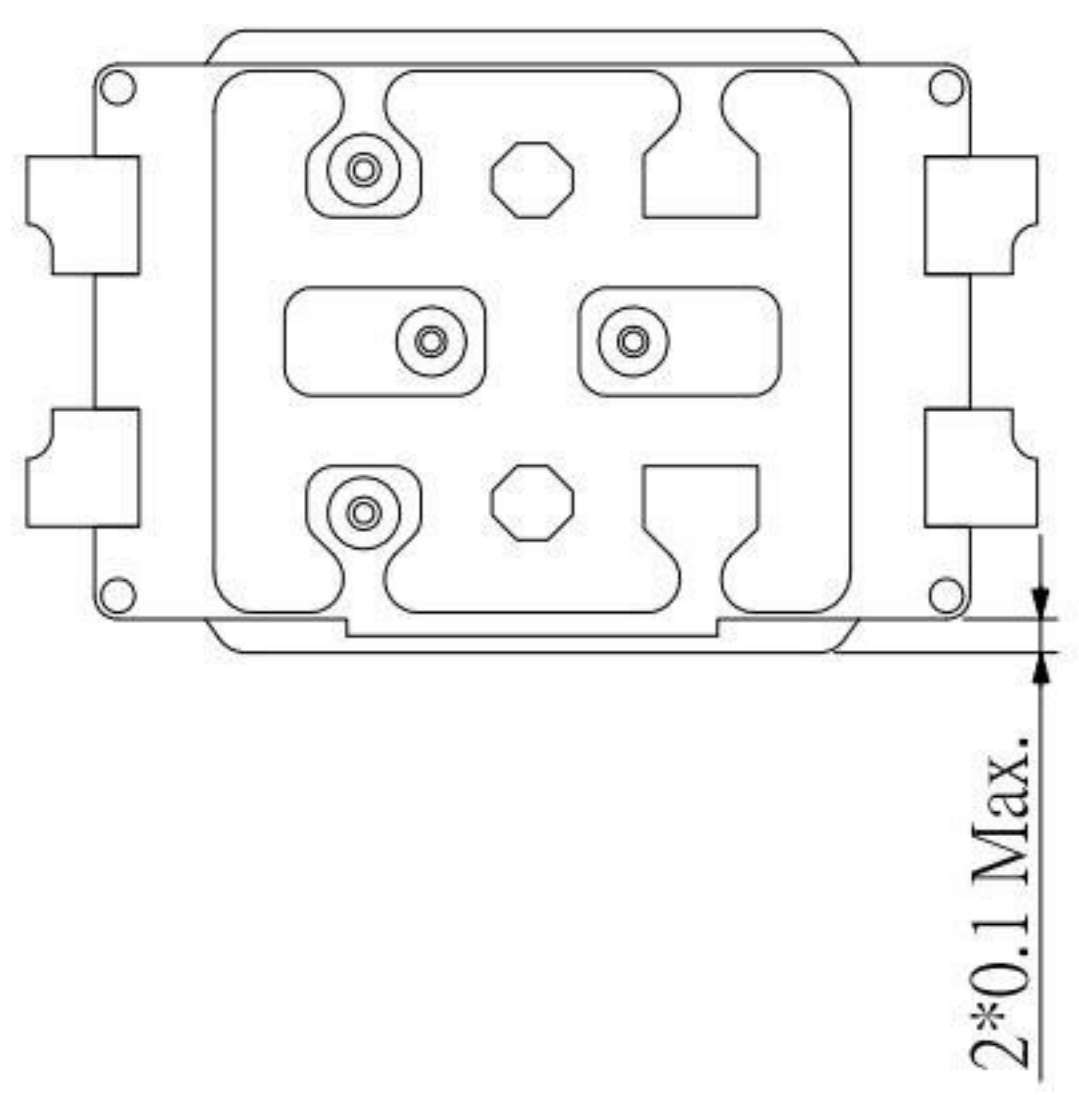

CIRCUIT DIAGRAM

SPECIFICATIONS

Rating	DC 15V, 20mA.		
Insulation Resistance	50 MΩ Min.		
Contact Resistance	500 mΩ Max.		
Dielectric Withstanding Voltage	AC 250V for 1 min		
Operating Force	0	100 ± 30gf	2 160 ± 50gf 3 240 ± 50gf
Travel	0.08mm	0.11mm	
Operating Life (cycles)	500,000		

KSD 科斯达电子科技有限公司
 SWITCH CONNECTOR 全球 互联零组件制造企业
KSD ELECTRONIC TECHNOLOGY Co., LTD

TOLERANCE UNLESS OTHERWISE STATED:
 Up to 5 ±0.2
 Above 5 ~ 15 ±0.3
 Above 15 ~ 30 ±0.4
 Above 30 ~ 50 ±0.5
 Angle ±0.3°

3RD. ANGEL'S

UNITS MM

DRAWN BY:	DATE	MAT'L	TITLE	SWITCH
Jack Lu	06/07/22		MODLE	TACT SWITCH
CHECKED BY:	DATE	FINISH	DWG NO.	TS-A30W-x-S182
Jacky Chen	06/07/22		SHEET NO.	1 of 1
APPROVED BY:	DATE	SCALE	PART NO.	TS-A30W-x-S182
Tony Kao	06/07/22	1:1		

ITEM NO.	DESCRIPTION	DRAWN	DATE