

PCB LAYOUT

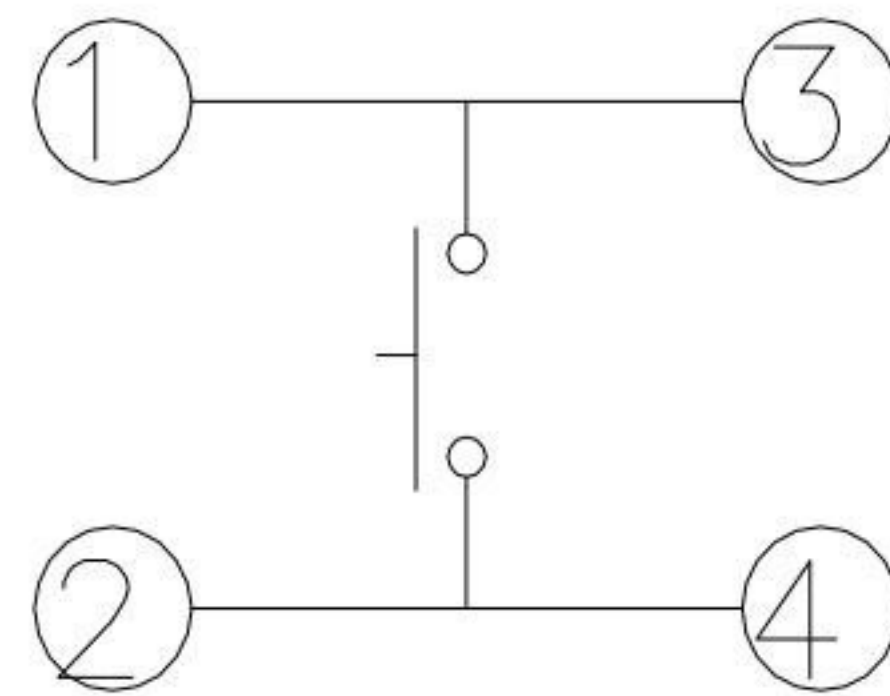
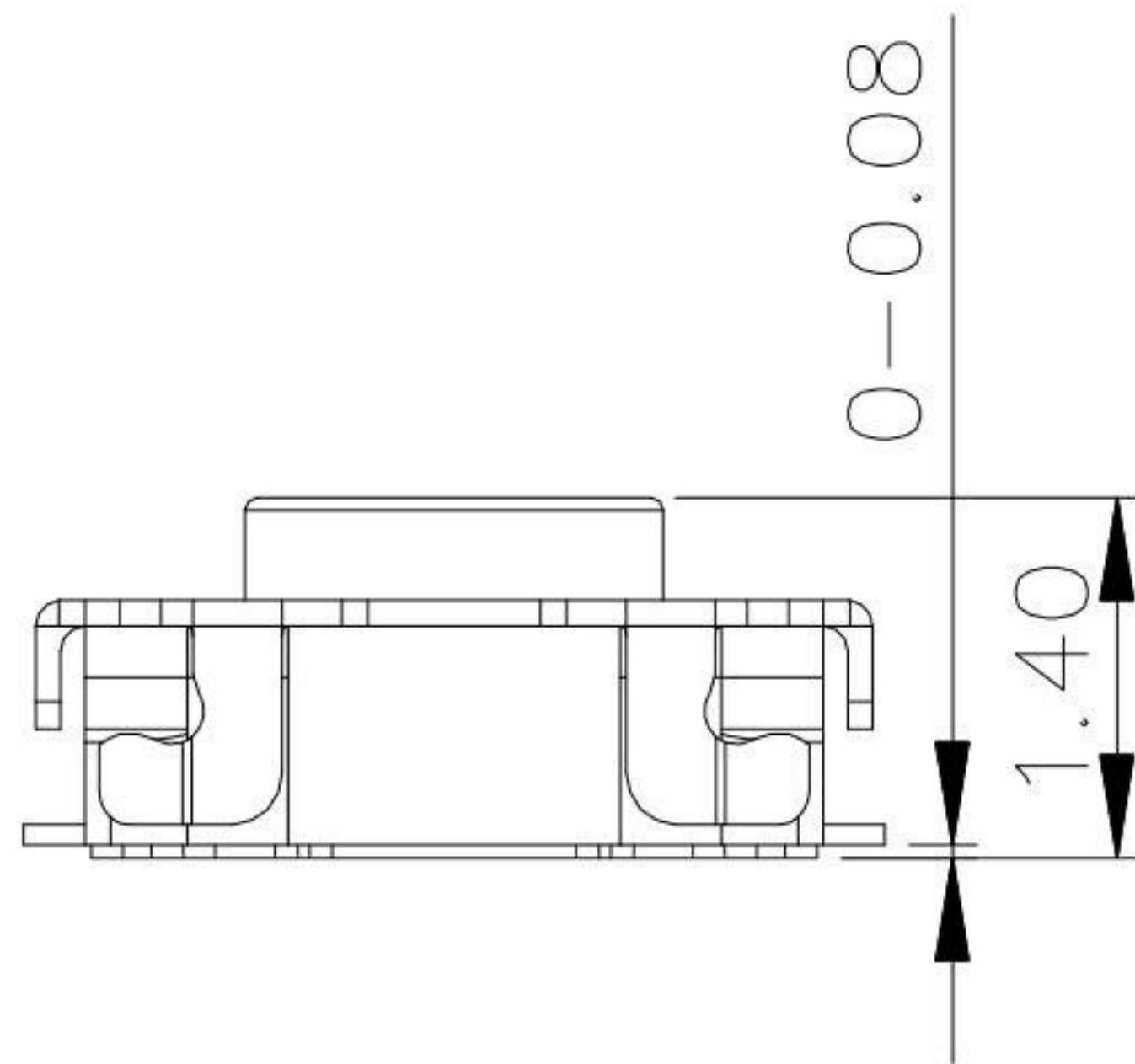

CIRCUIT DIAGRAM

SPECIFICATIONS

Rating	DC 12V, 50mA.				
Contact Resistance	100 mΩ Max.				
Operating Force	10	80 ± 30gf	2	160 ± 50gf	3 260 ± 50gf
Operating Life (cycles)	200,000		100,000		

NO.	DESCRIPTION	QTY	MATERIAL	PLATING
E	TERMINAL	4	PHOSPHOR BRONZE	Ag plated
D	BASE	1	LCP	
C	CONTACT	1	SUS	Ag plated
B	COVER	1	SUS	
A	STEM	1	LCP	

**KSD** 科斯达电子科技有限公司  
 SWITCH CONNECTOR KSD ELECTRONIC TECHNOLOGY Co., LTD  
 全球 互联零组件制造企业

TOLERANCE UNLESS OTHERWISE STATED:  
 Up to 5 ±0.2  
 Above 5 ~ 15 ±0.3  
 Above 15 ~ 30 ±0.4  
 Above 30 ~ 50 ±0.5  
 Angle ±0.3°

3RD. ANGEL'S  
 UNITS MM

DRAWN BY: Jack Lu  
 CHECKED BY: Jacky Chen  
 APPROVED BY: Tony Kao

DATE: 03/20/23  
 DATE: 03/20/23  
 DATE: 03/20/23  
 MAT'L  
 FINISH  
 SCALE: 1:1  
 SHEET NO.: 1 of 1  
 TITLE: SWITCH  
 MODLE: TACT SWITCH  
 DWG NO.: TS-A82-x-S138  
 PART NO.: TS-A82-x-S138

ITEM NO.	DESCRIPTION	DRAWN	DATE
1	新增 Operating Force: 80±30gf	Jack	032023

SIZE: A4  
 VER: R1